

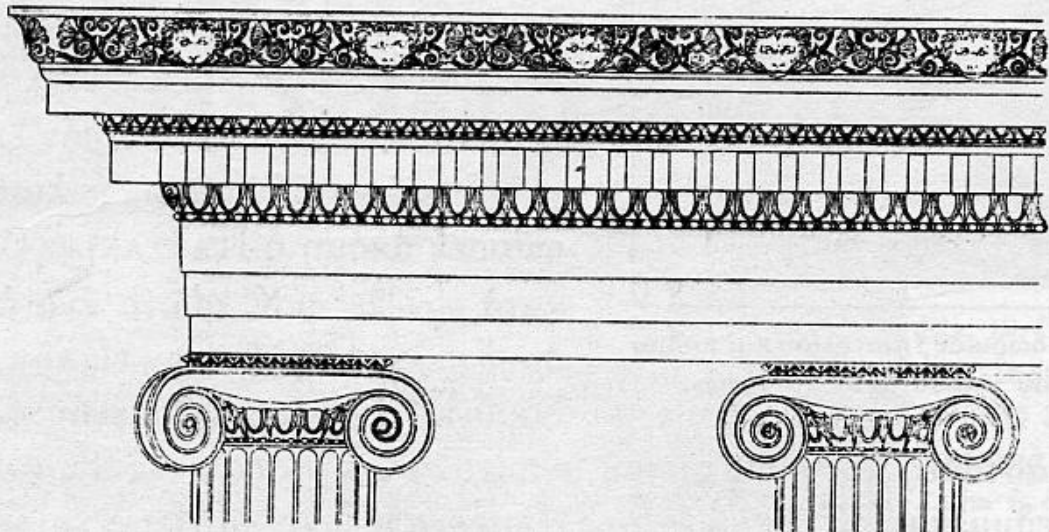

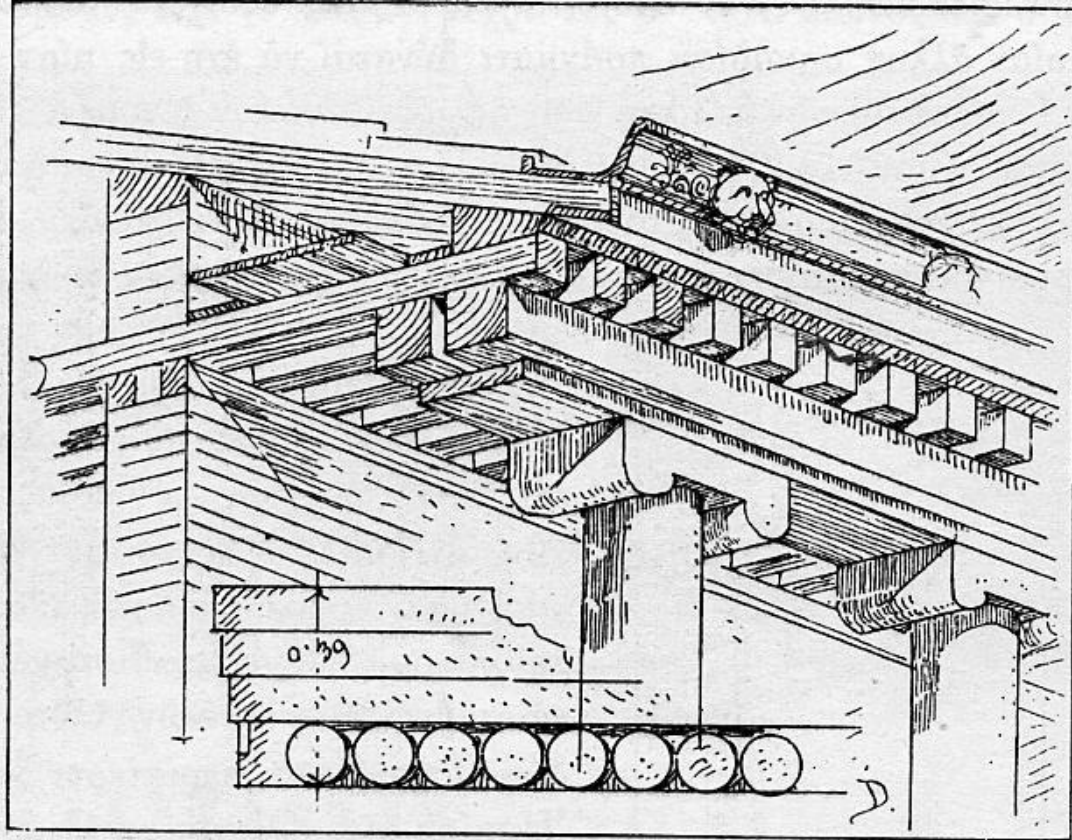

# ORIGINS OF THE IONIC ORDER





# FLAT ROOF

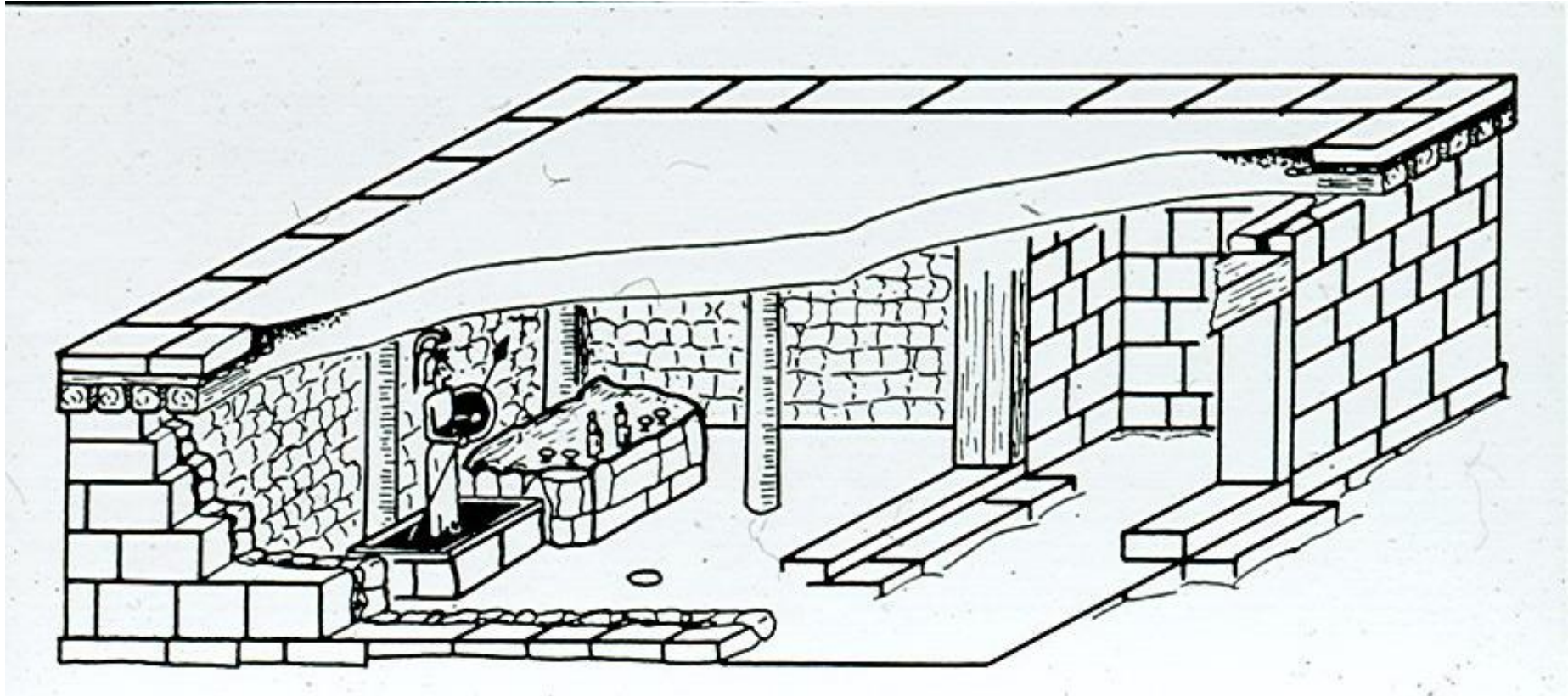

**CHIOS, TEMPLE OF THE 6<sup>th</sup> C. B.C.**



ΕΜΠΟΡΙΟ ΧΙΟΥ.  
Ο ναός της Αθηνάς  
(δοτικός τοίχος)

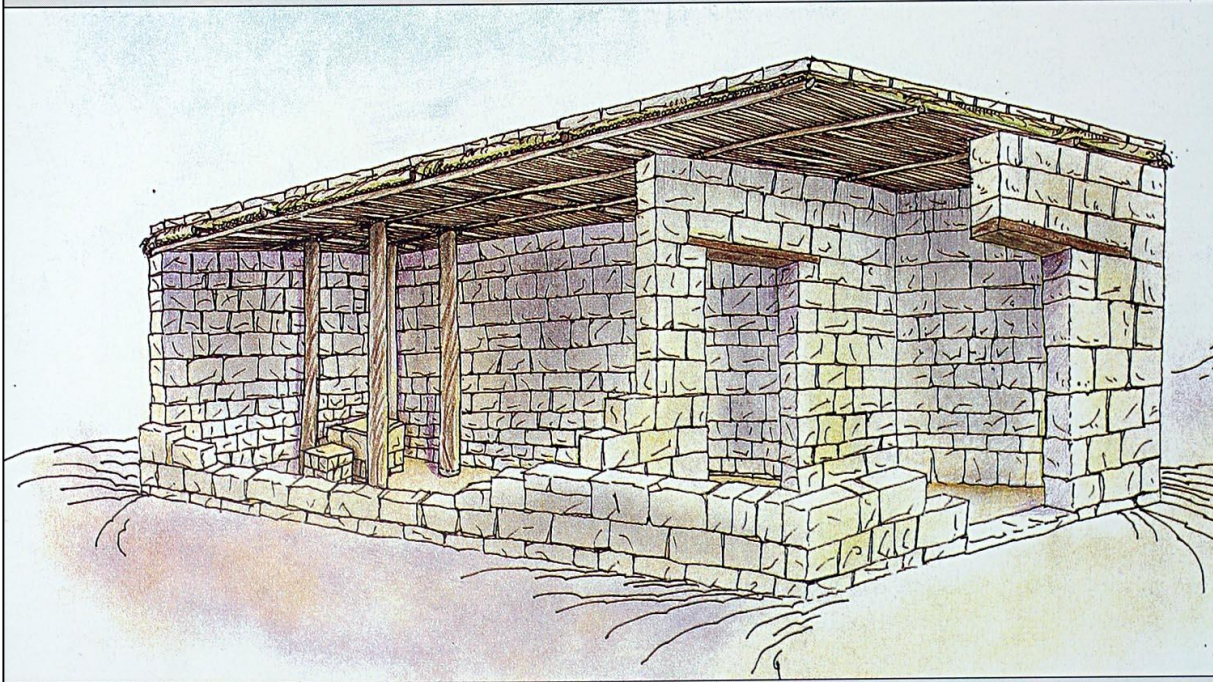

δοκιμαστική  
αναπαράσταση









## AEOLIC CAPITALS

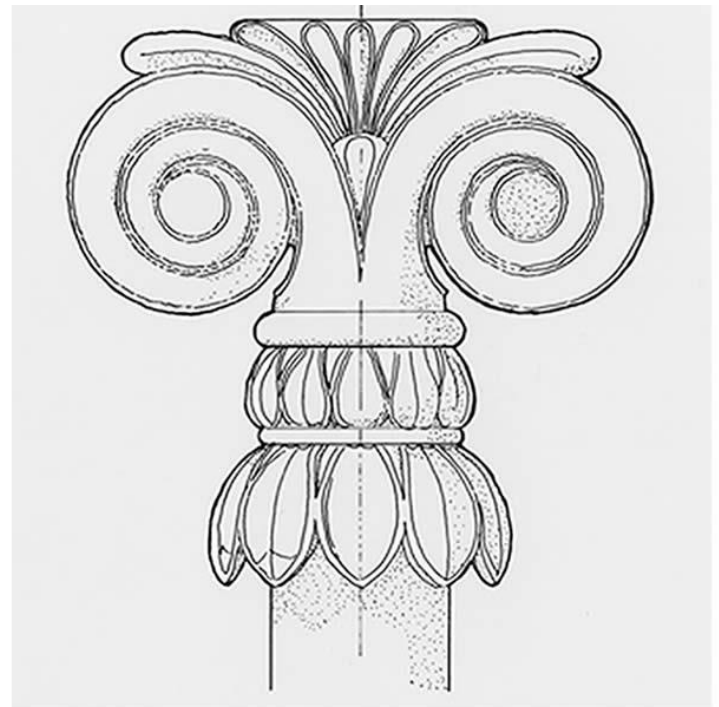

# HATHOR

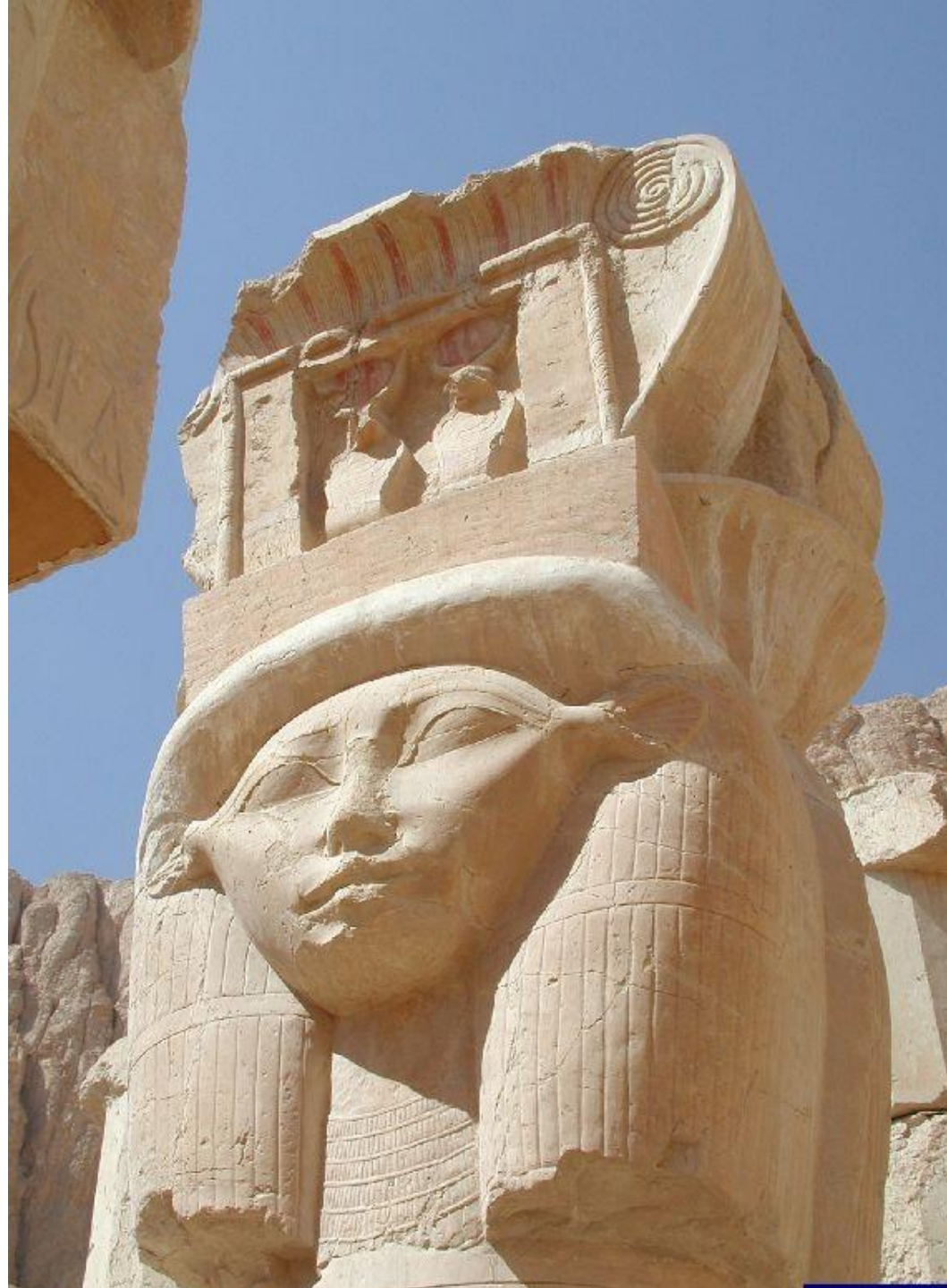

# IONIC VOTIVE COLUMNS



# ARCHAIC IONIC

- A VOLUME
- IMAGINATION, INVENTION, EMOTIONAL
- VARIETY OF PROPORTIONS

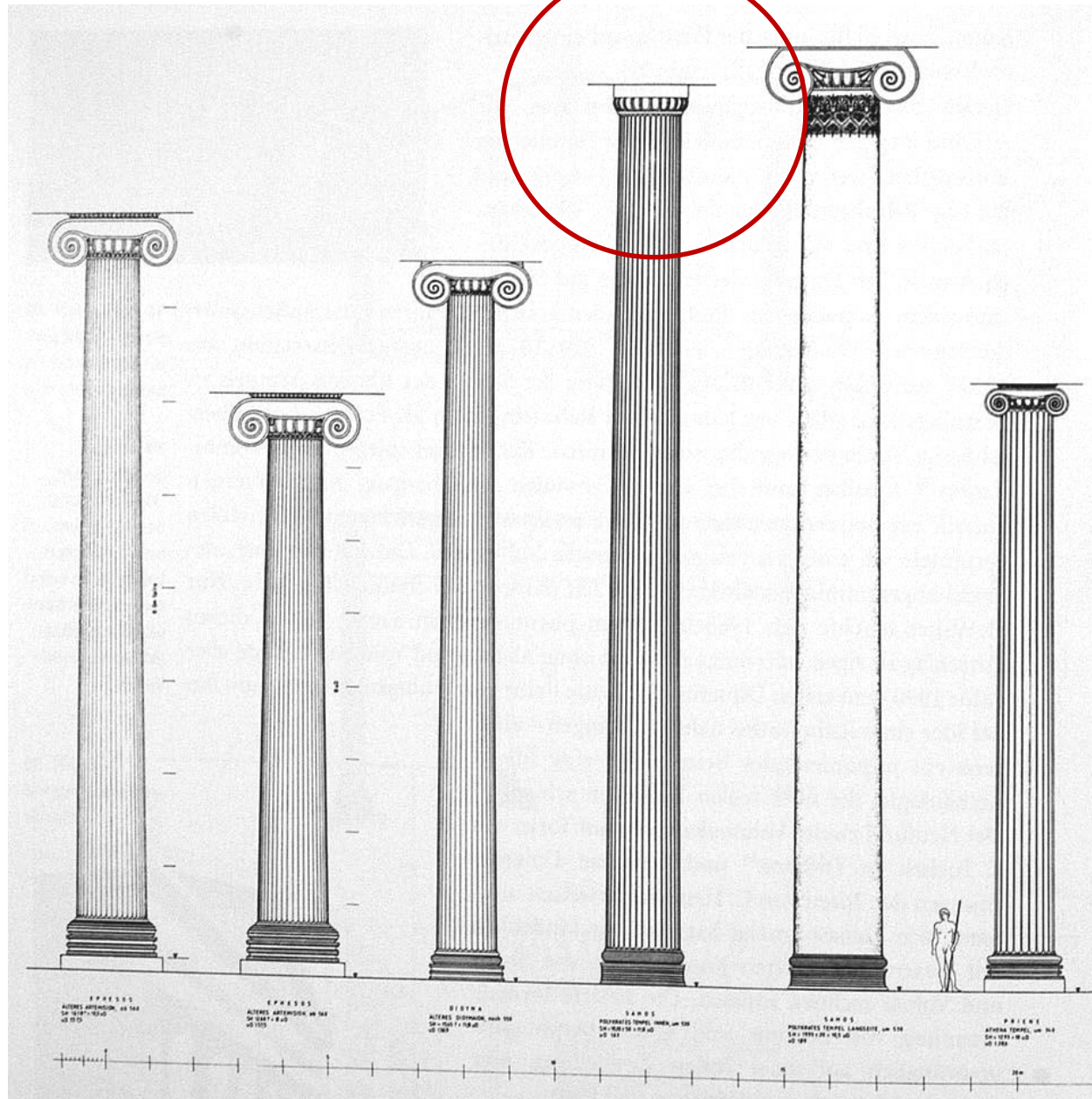





**Brigitte CS**





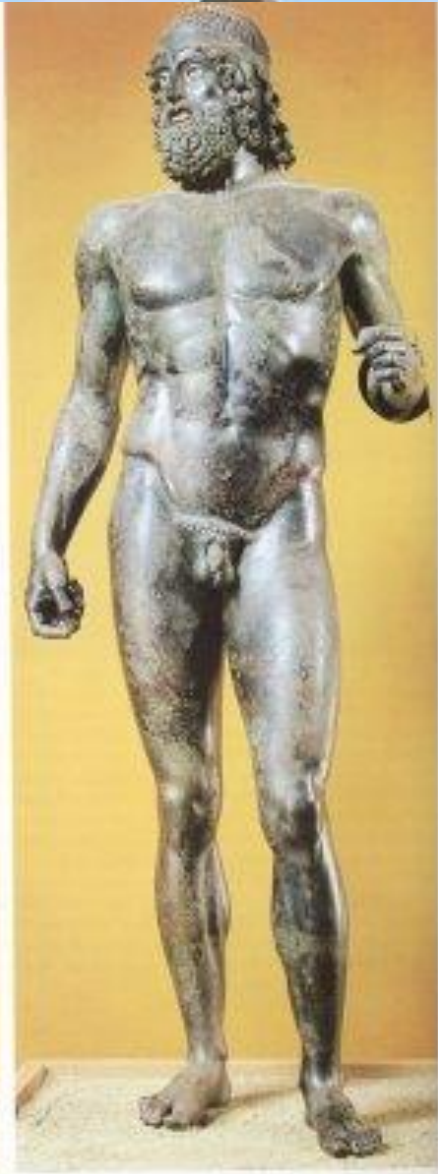

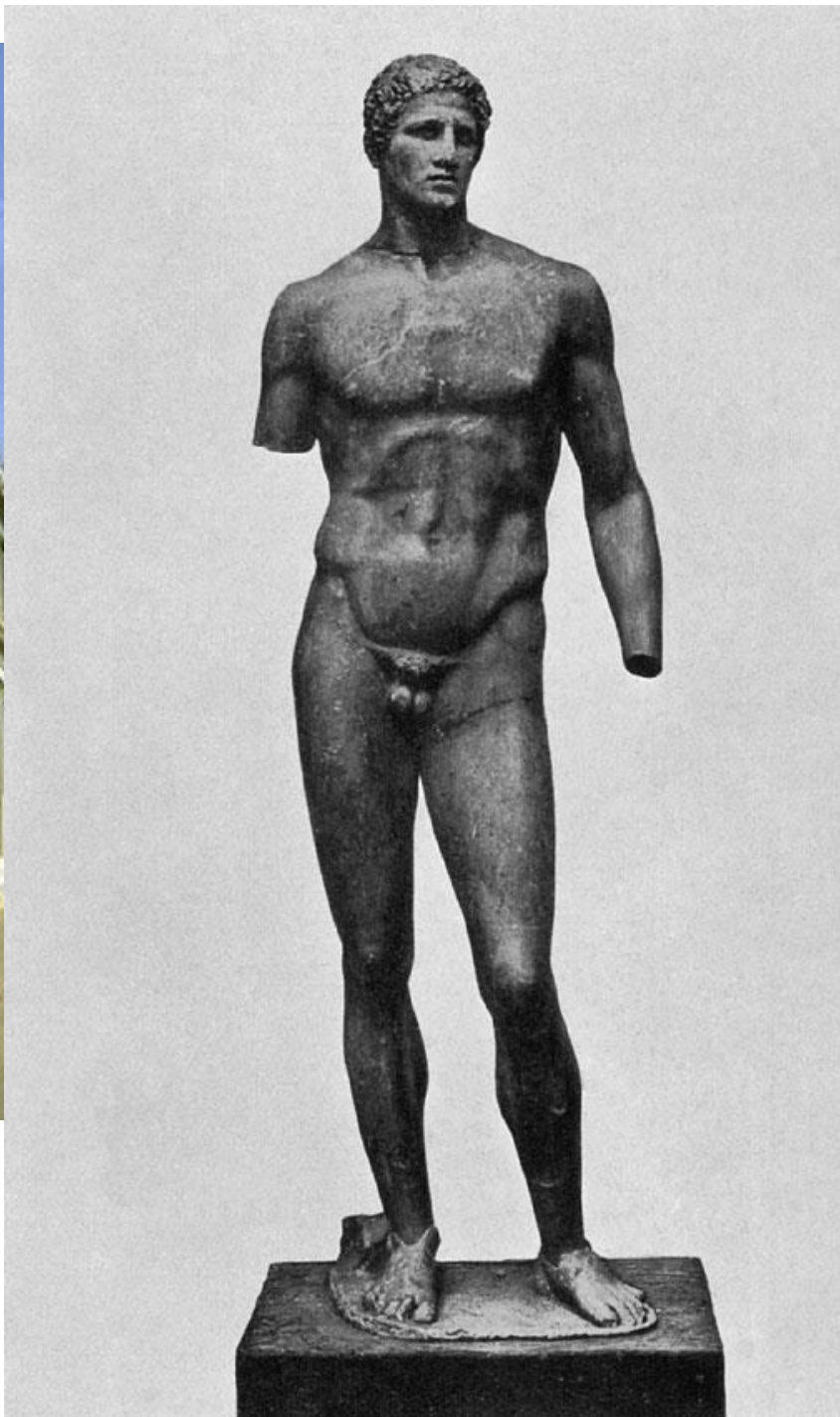





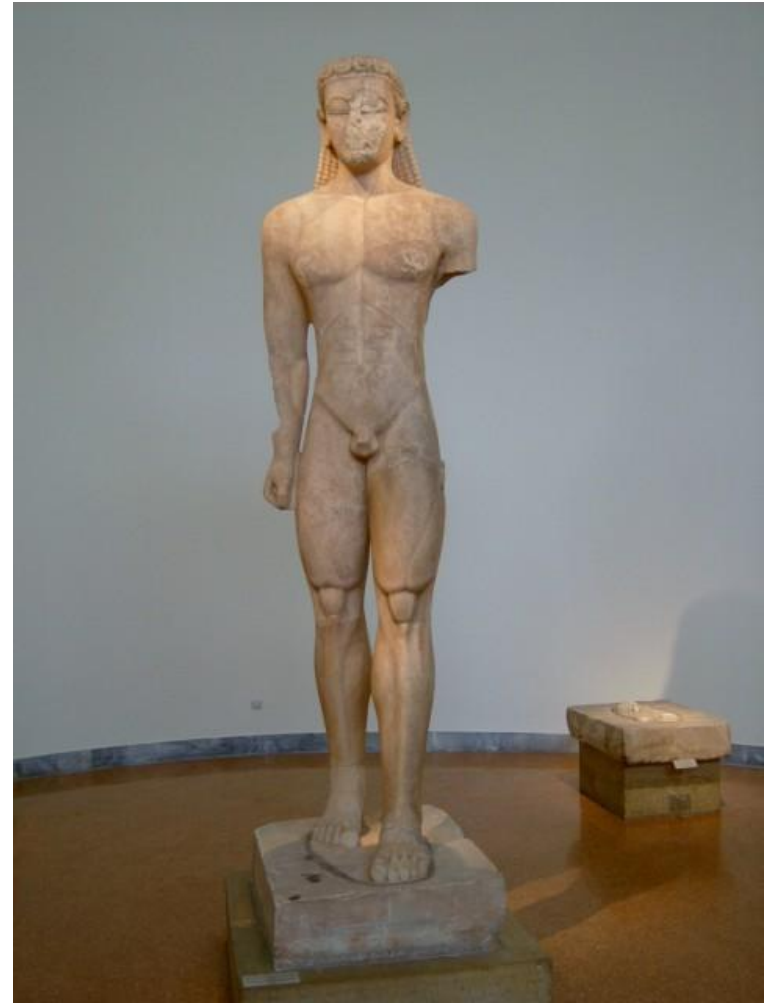



# ΗΡΑΙΟΝ, ΔΗΛΟΣ (500 π.Χ.)

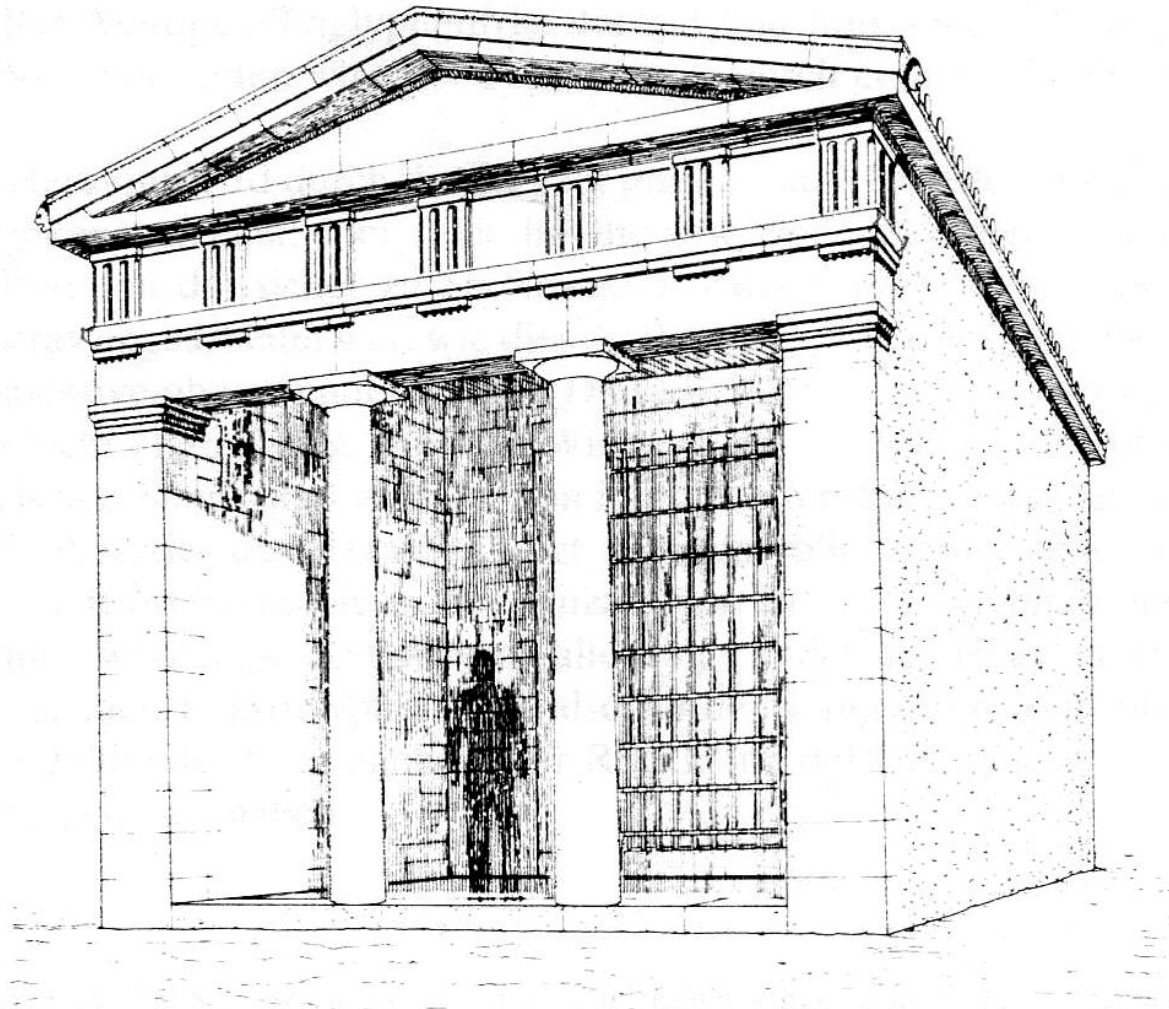





# ΔΗΛΙΟΝ, ΠΑΡΟΣ

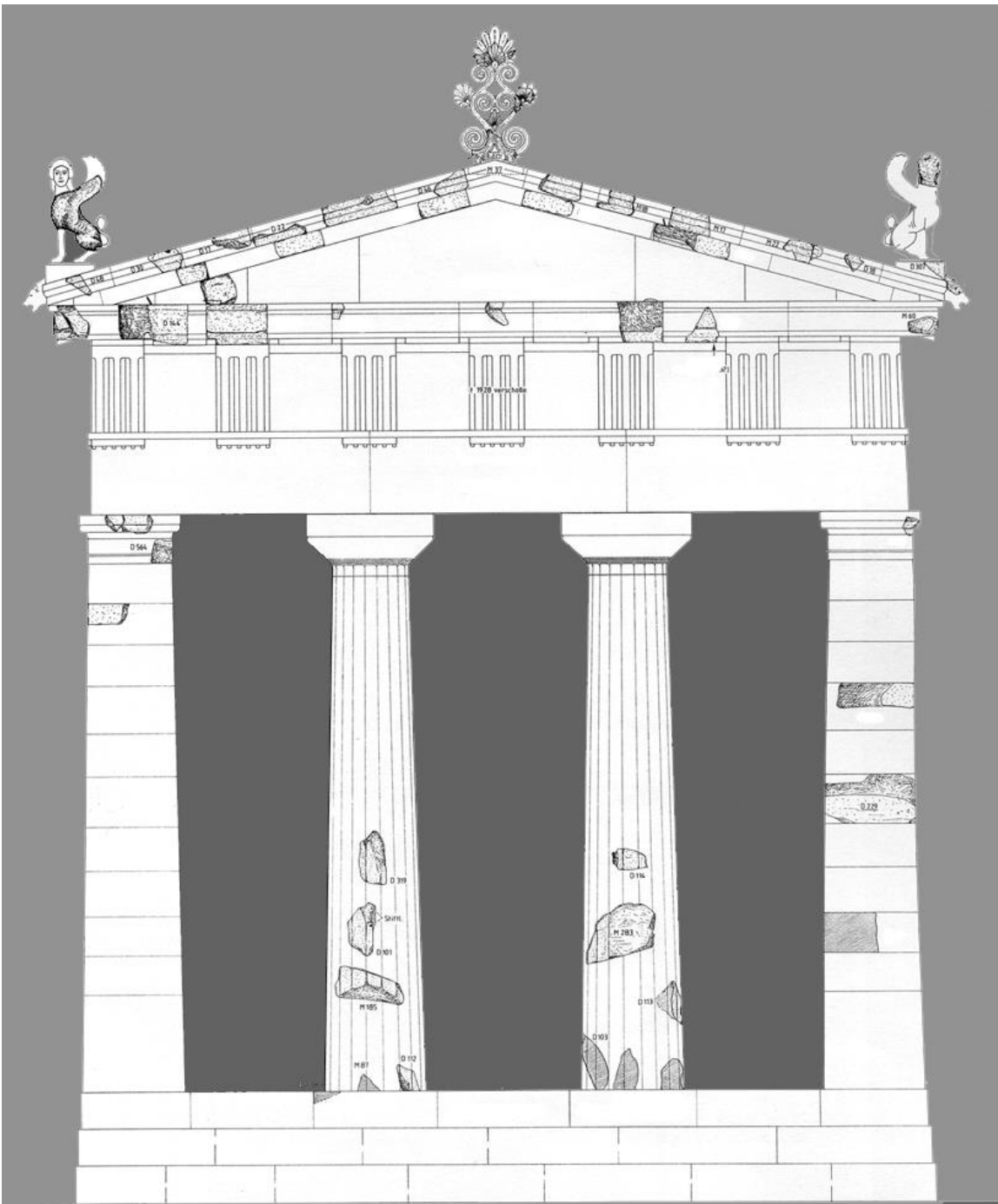

# ARCHAIC IONIC TEMPLES

- OIKOS OF NAXIANS, ΔΗΛΟΣ (590)
- HERA TEMPLE III, SAMOS
- ARTEMIS TEMPLE, EPHEOS
- HERA TEMPLE IV, SAMOS
- APOLLO, MILETOS (540)
- SAGKRI, NAXOS (540-530)
- APOLLO TEMPLE, NAXOS (530)

ΙΕΡΑ

Σάμος



Εκατόμπεδος 1

Βάση

φρέατα

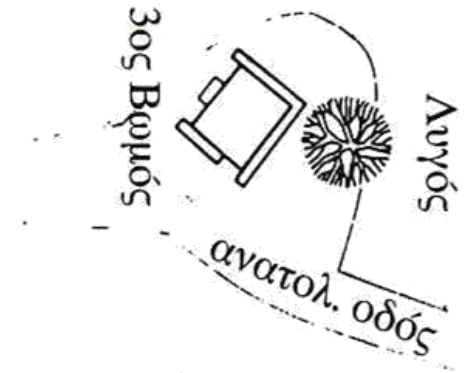
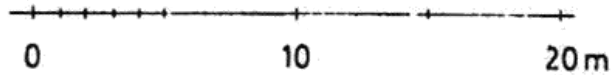

**ο πρώτος εκατόμπεδος ναός στο Ηραίο της Σάμου (ύστερος 8<sup>ος</sup> αι. π.Χ.)**

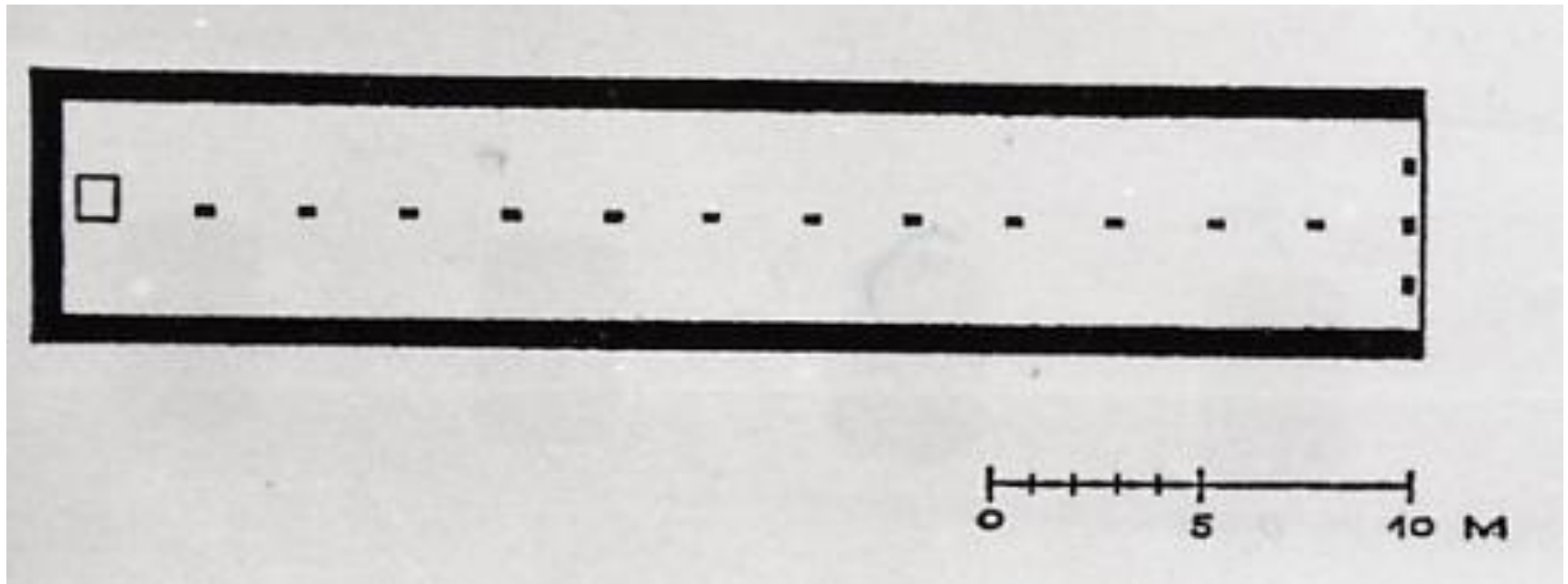

**TEMPLE I HERA, SAMOS LATE 8<sup>TH</sup> C. B.C.**

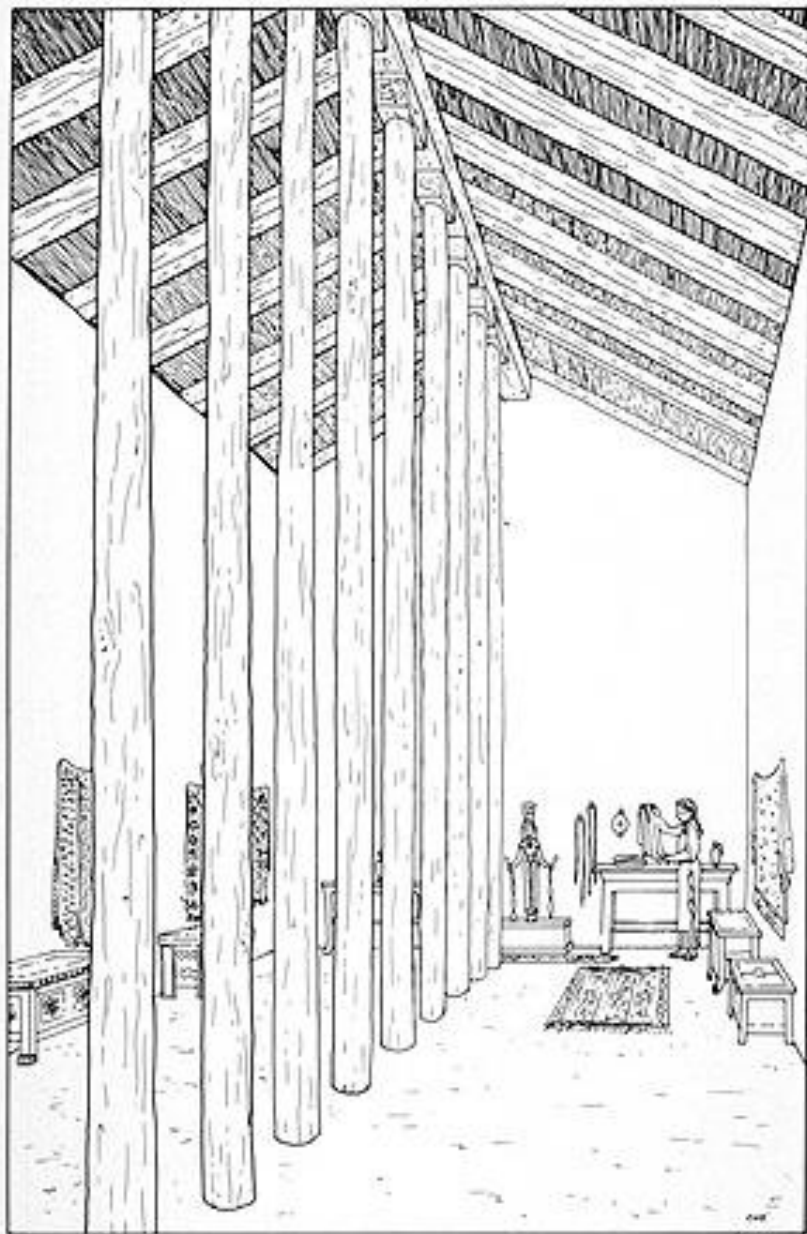

# SAMOS

## TEMPLE I HERA, SAMOS LATE 8<sup>TH</sup> C. B.C.

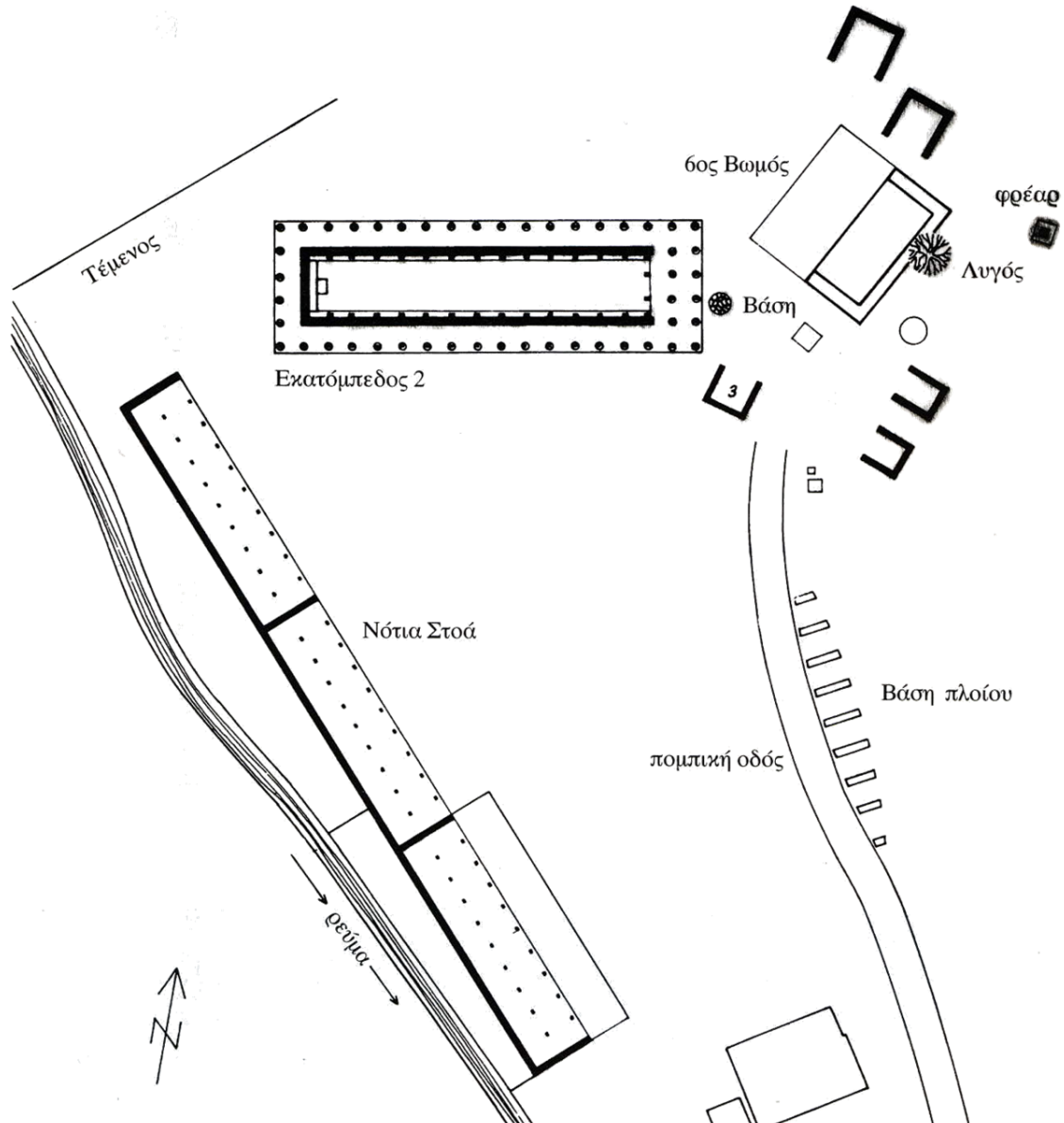

HERA TEMPLE II MID 7c.  
B.C.

# SAMOS



**BASE FOR WOODEN PILLAR.  
7 C. B.C.**



# SAMOS

## Ναοί I-IV

- TEMPLE I
- TEMPLE II
- DIPTERAL TEMPLE III
- DIPTERAL TEMPLE IV

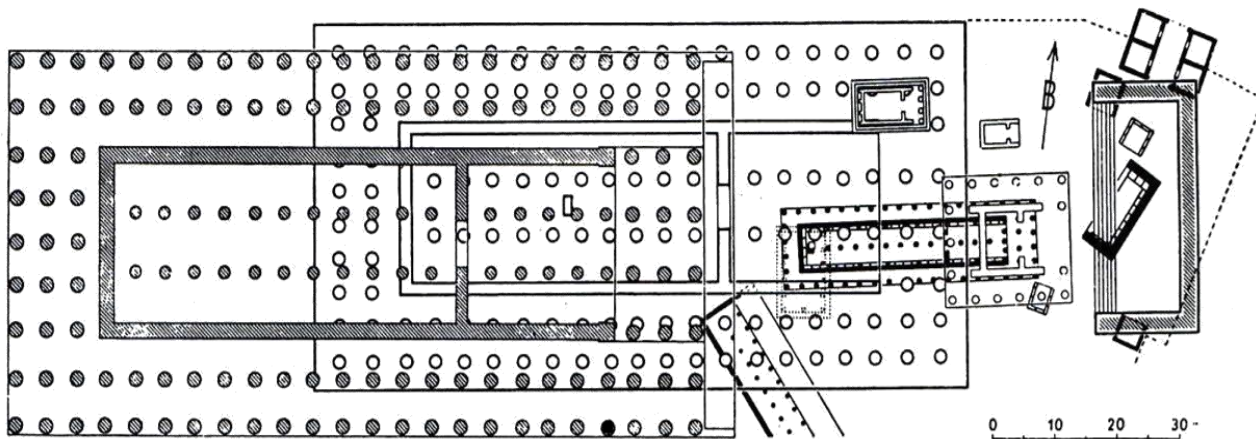
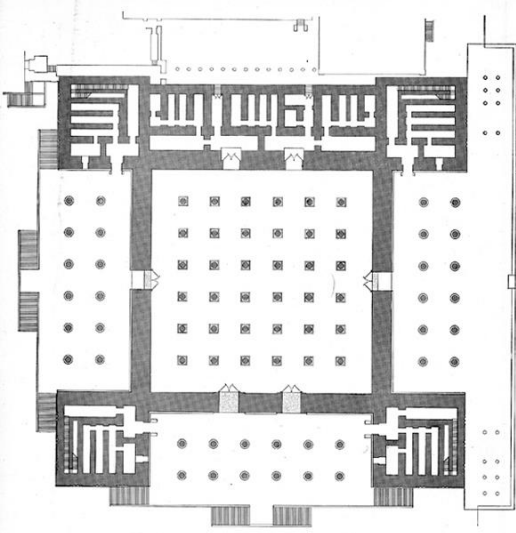

**INCREASE OF SIZE**

# HERA TEMPLE III. SAMOS

- SHALLOW FOUNDATION
- BASES SPINNED ON A LATHE
- WOODEN CAPITALS

# SAMOS

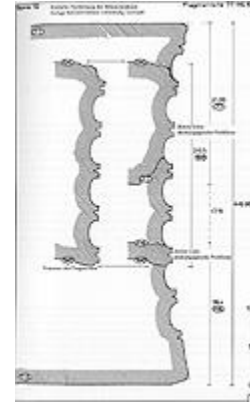

HERA TEMPLE III)  
εντοιχισμένοι στον  
υστερότερο ναό



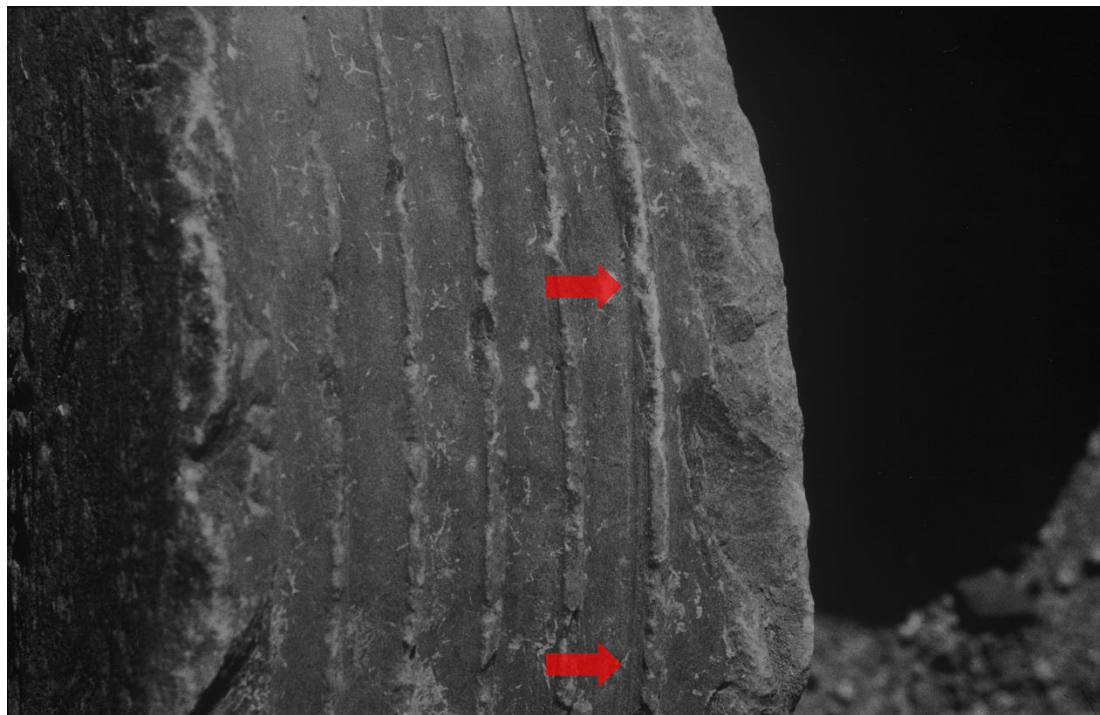
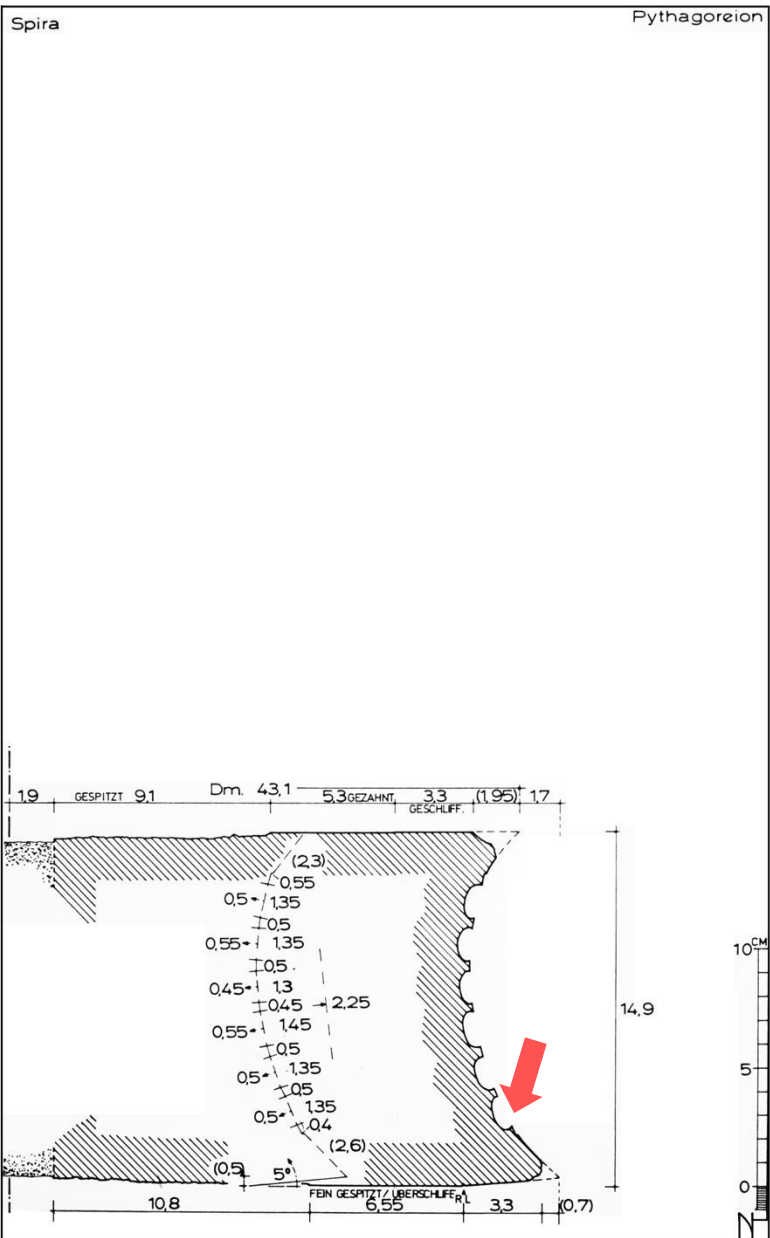

ια ίχνη του  
 τόνου επί



**LATHE  
MARKS**

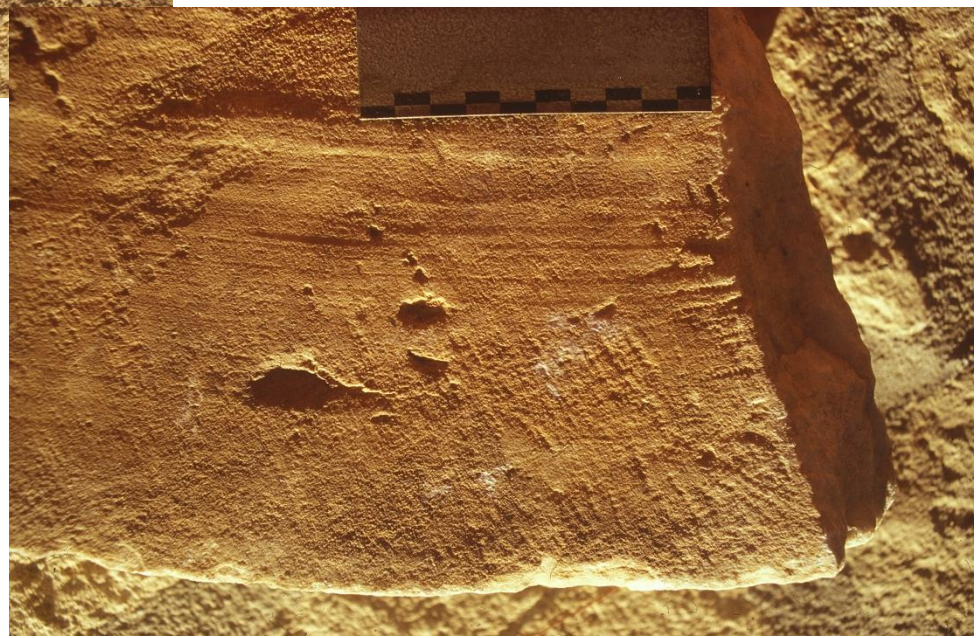
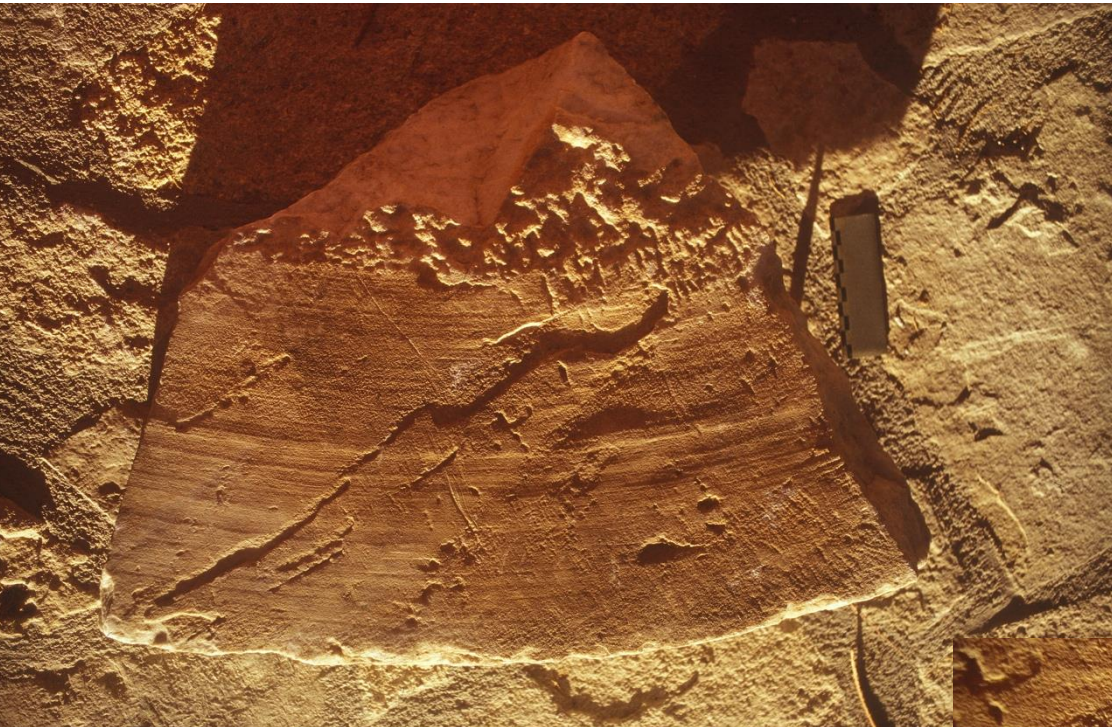

**LATHE  
MARKS**



**LATHE  
MARKS**

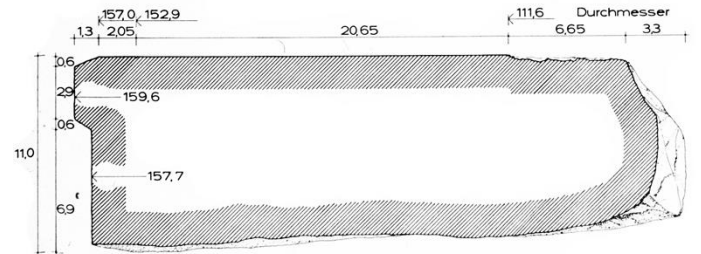
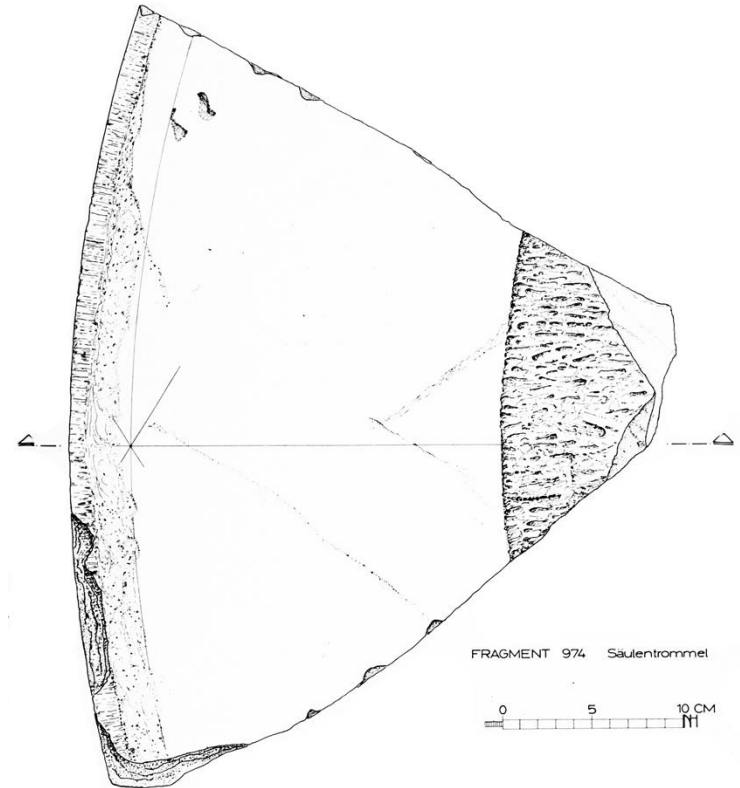

# TUNNEL AND CONDUIT

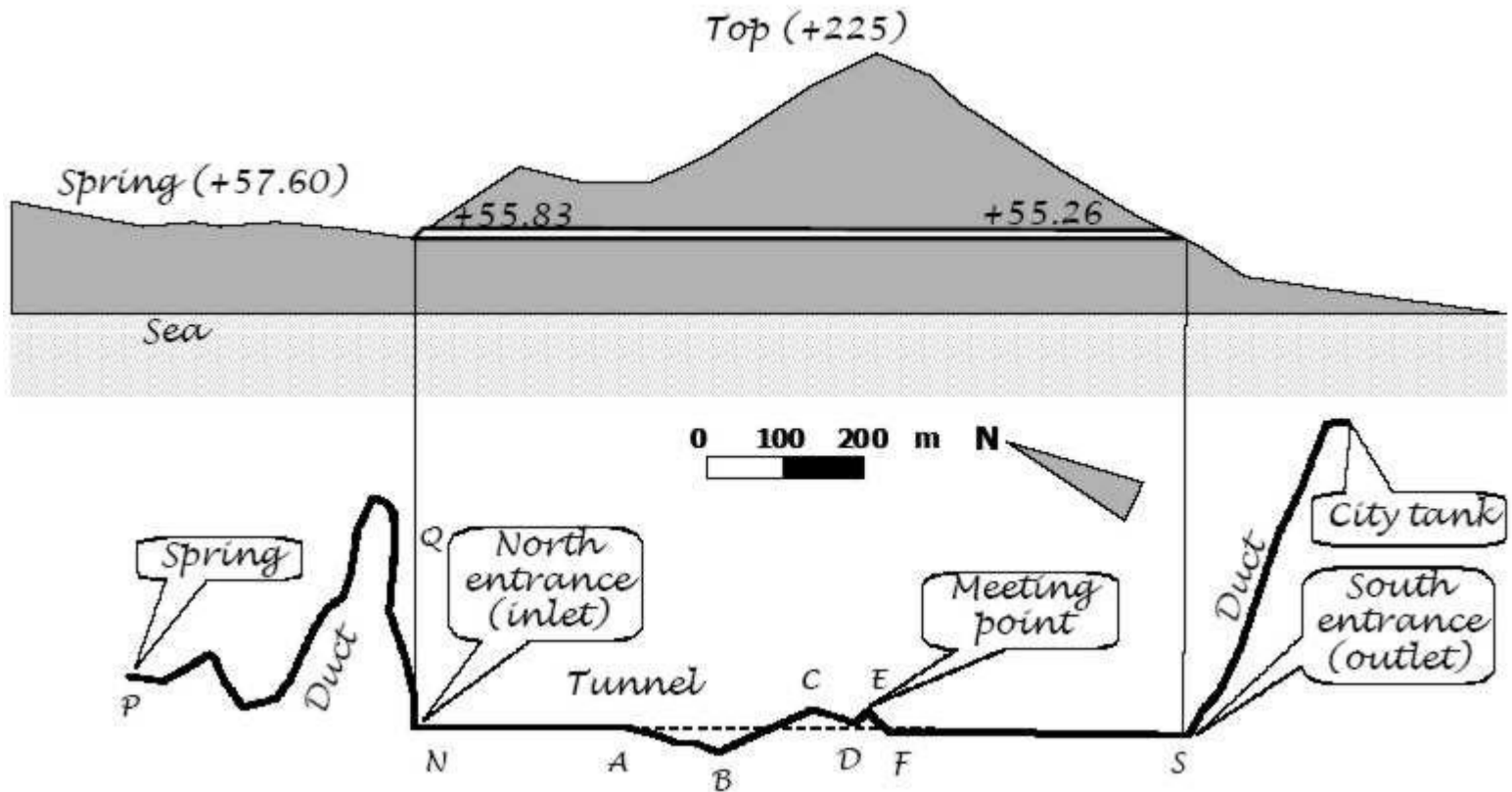



# HERA TEMPLE IV. SAMOS 'POLYCRATES' 538-522 B.C.-end of 4<sup>th</sup> c. B.C..



# HERA SAMOS

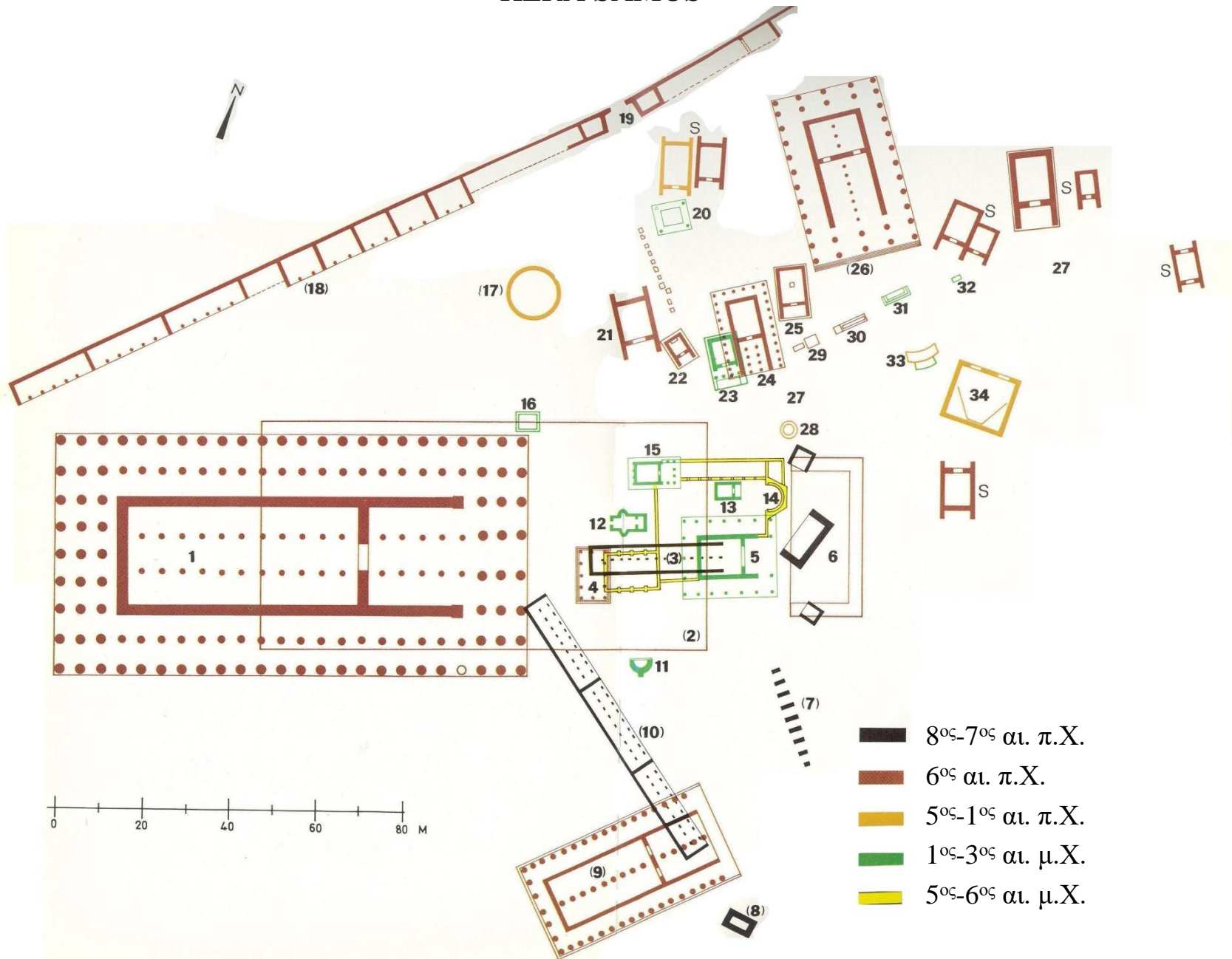

- 8<sup>ος</sup>-7<sup>ος</sup> αι. π.Χ.
- 6<sup>ος</sup> αι. π.Χ.
- 5<sup>ος</sup>-1<sup>ος</sup> αι. π.Χ.
- 1<sup>ος</sup>-3<sup>ος</sup> αι. μ.Χ.
- 5<sup>ος</sup>-6<sup>ος</sup> αι. μ.Χ.

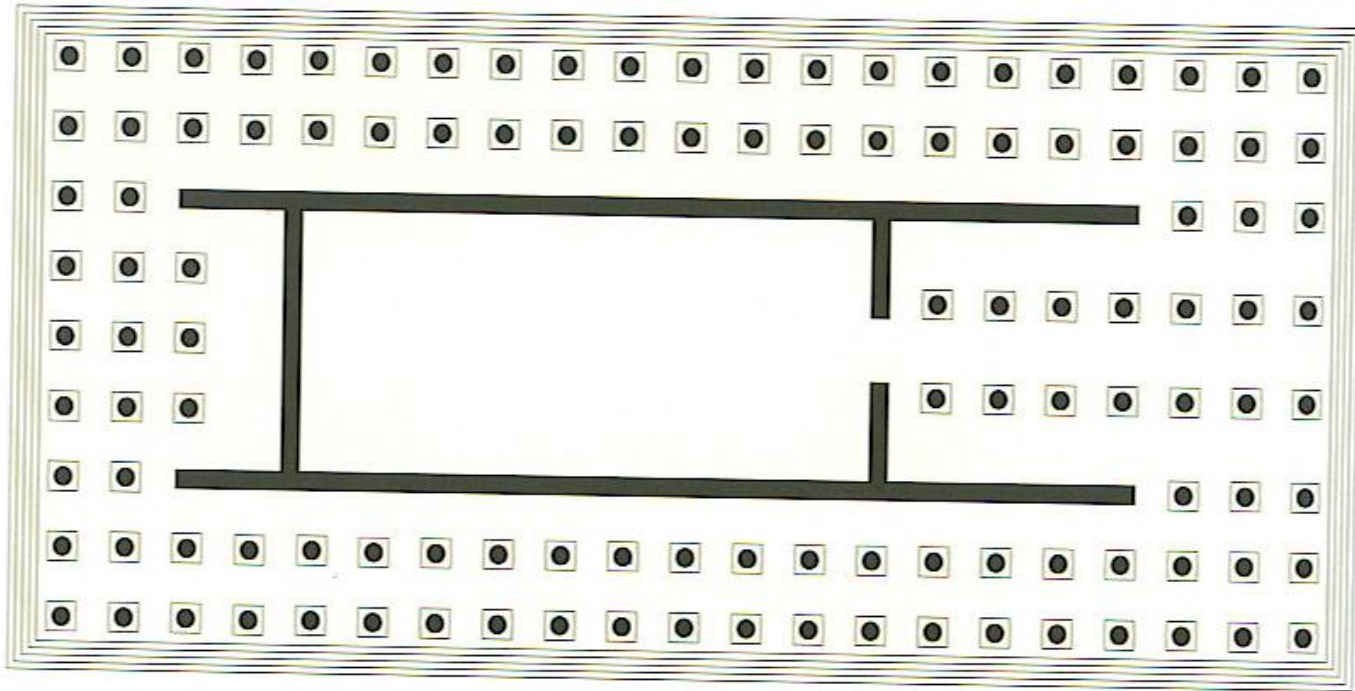

ARTEMIS TEMPLE  
EPHESOS 550 π.X.

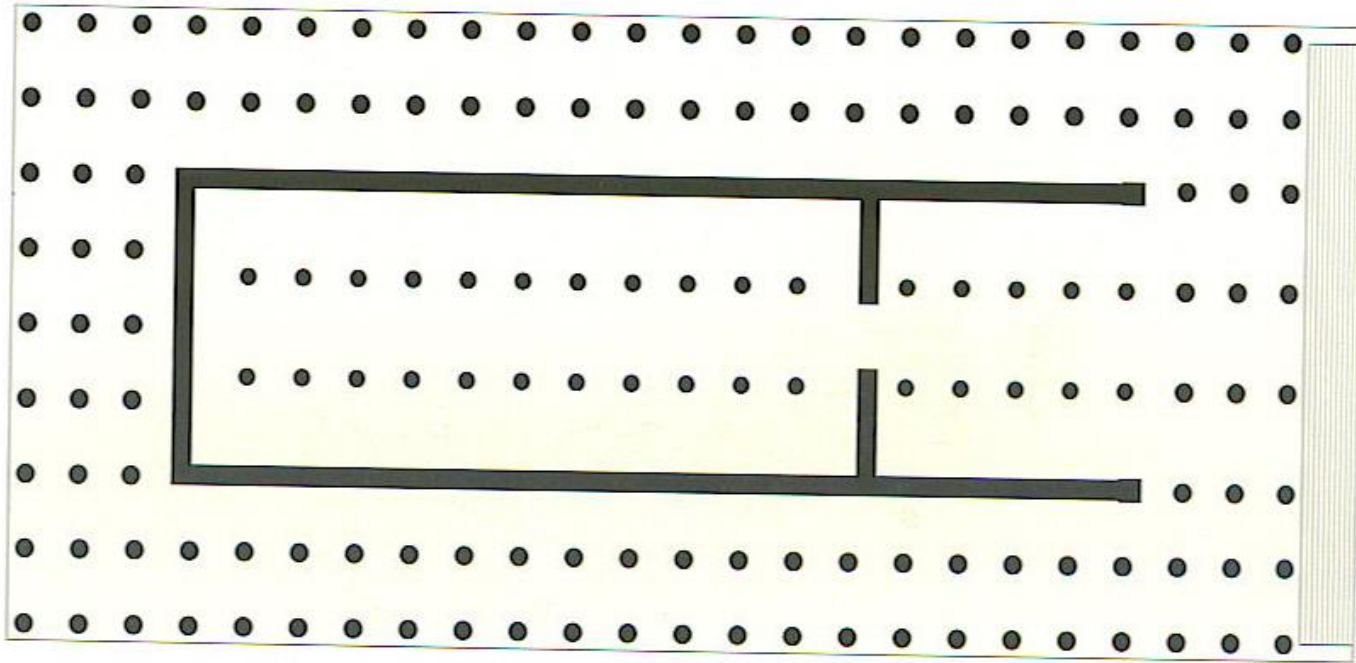

HERAA TEMPLE IV  
SAMOS 538 π.X.

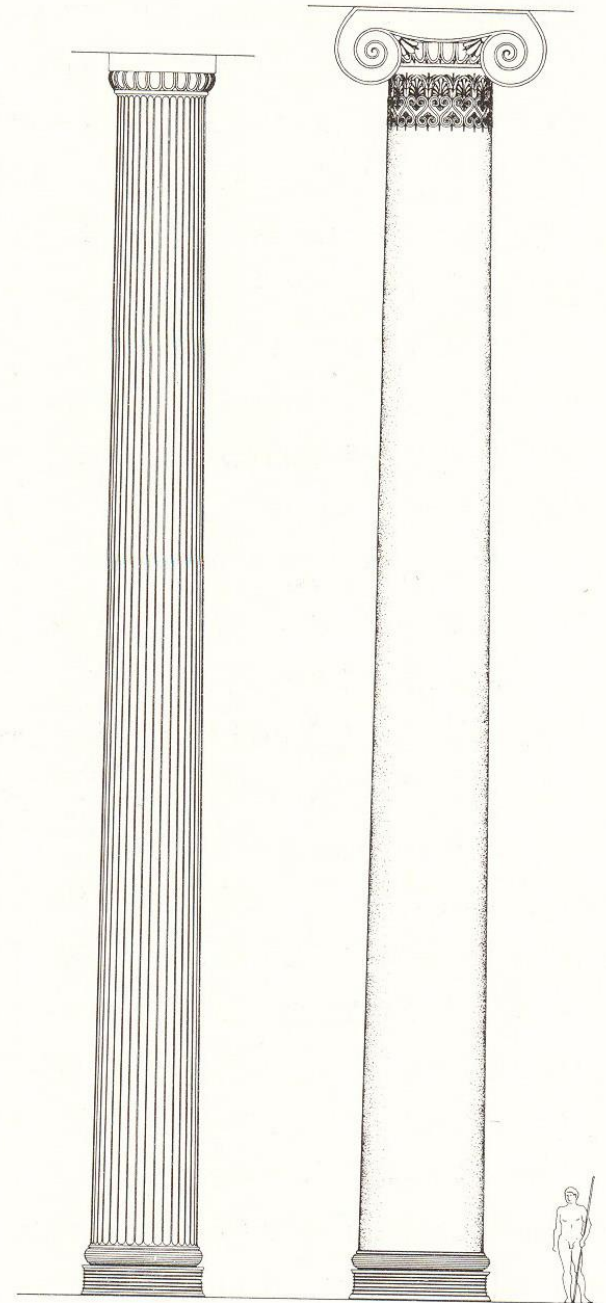

# ΣΑΜΟΣ

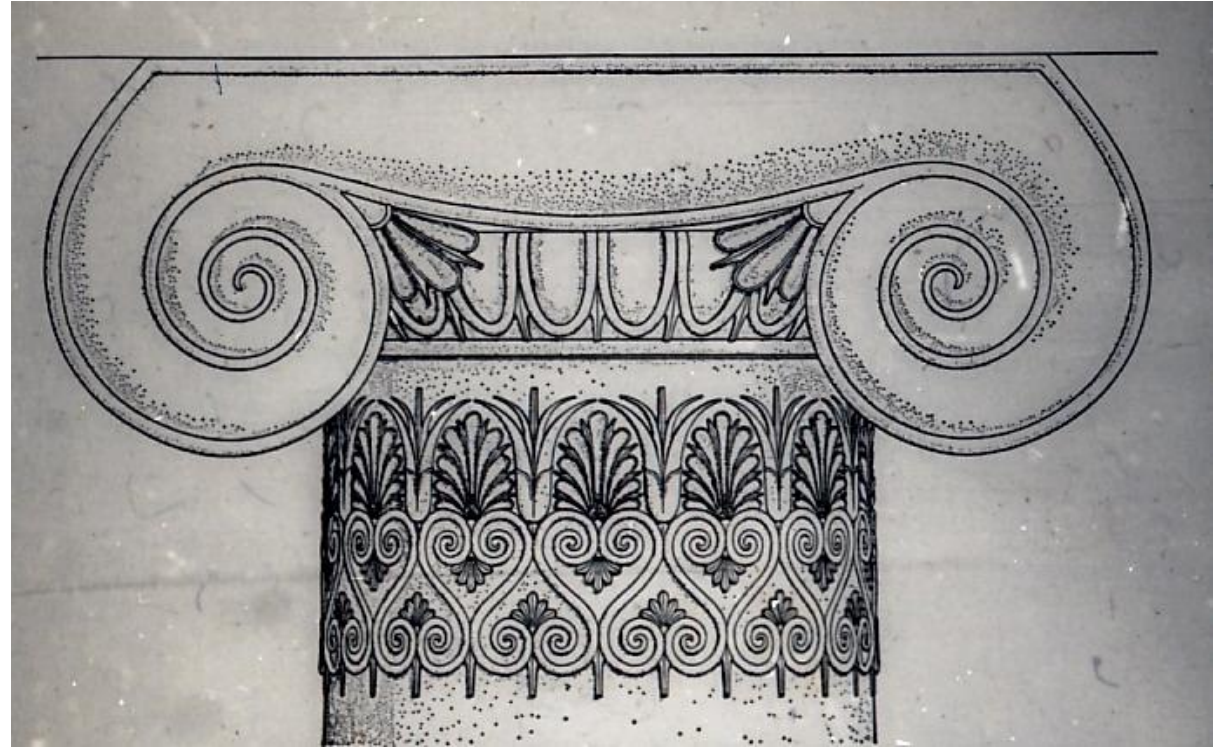
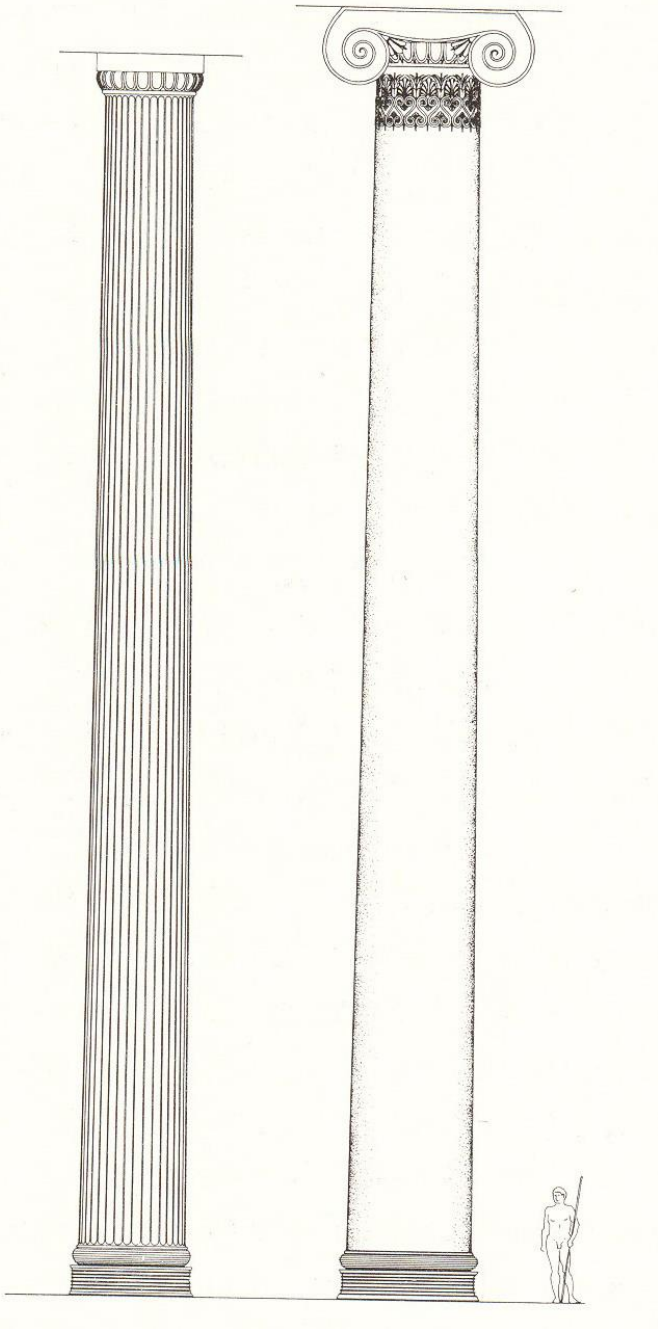

CAPITAL FROM HERA TEMPLE IV  
(480 B.C.)

# SAMIAN BASE

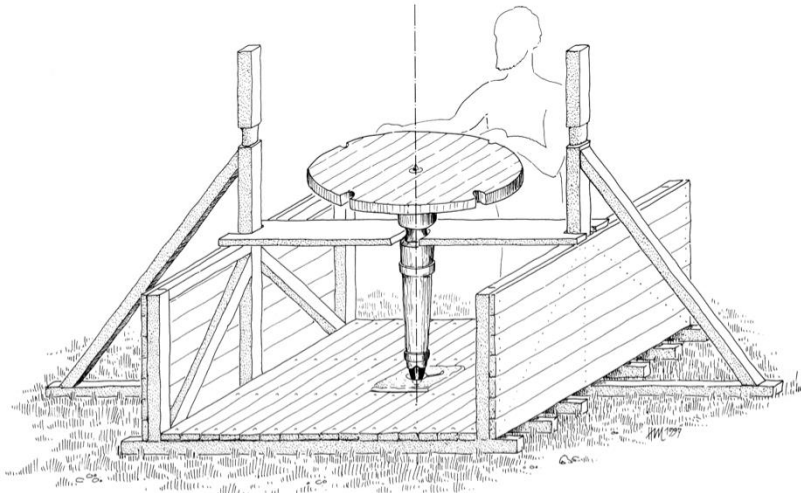

Rekonstruktion des Tornos

Rekonstruktion des Werkvorgangs

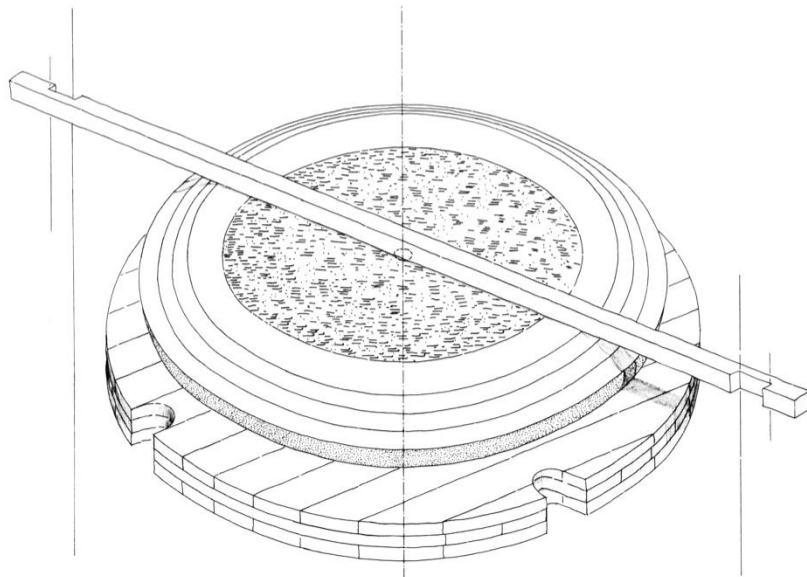
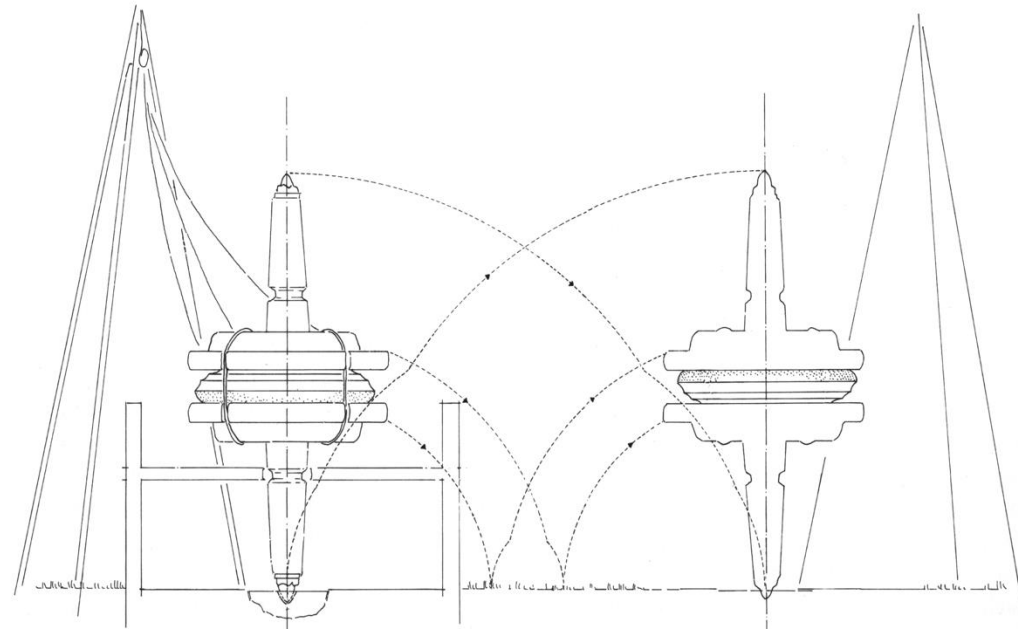

Werkstück auf der Drehscheibe mit in das Zentrierloch einrastender Anlegeschiene

Ionische Säulenbasen des 6 Jhs vChr

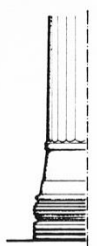

Naukratis, Apollon-T  
um 566 v Chr.  
(W.M. Flinders Petrie)



Delphi, Säule d. Naxier  
um 570 v Chr.  
(G. Kaster)



Delos, Oikos d. Naxier  
um 600 v Chr.  
(Innenraum, P. Courbin)

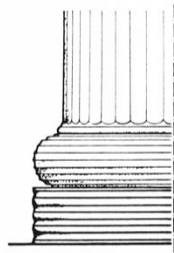

Samos, I Dipteros  
um 560 v Chr.  
(H. Johannes)

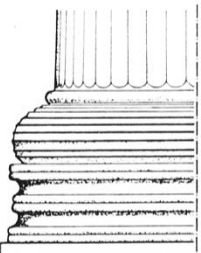

Ephesos, alte Artemision  
um 550 v Chr.  
(F. Krischen)

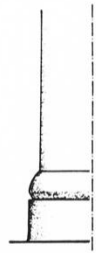

Delos, Oikos d. Naxier  
um 550 v Chr.  
(Prostylos, P. Courbin)

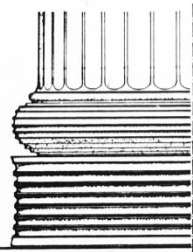

Samos, II Dipteros  
um 530 v Chr.  
(Pronaos)



Chios, Phanai  
um 500 v Chr.  
(Fragmente, W. Lamb)



Naxos, Sangri  
um 530 v Chr.  
(G. Gruben)

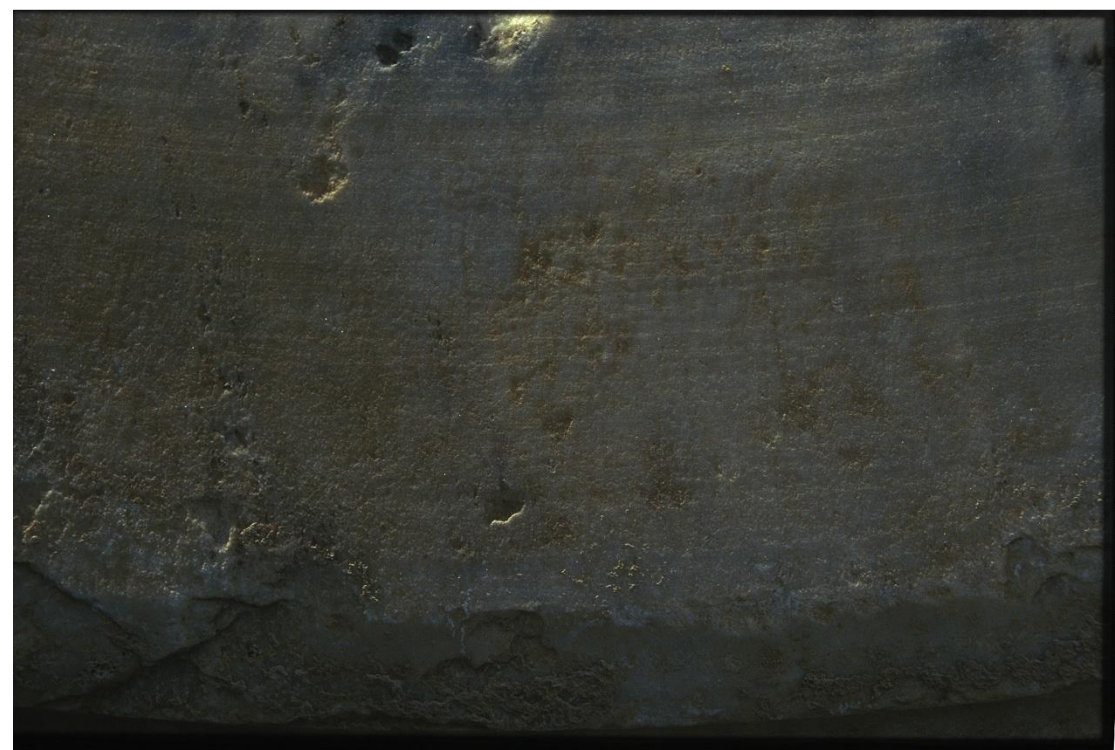
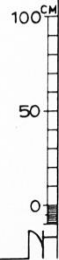

# HERA TEMPLE, SAMOS

- DIAMETER 2.30 μ.





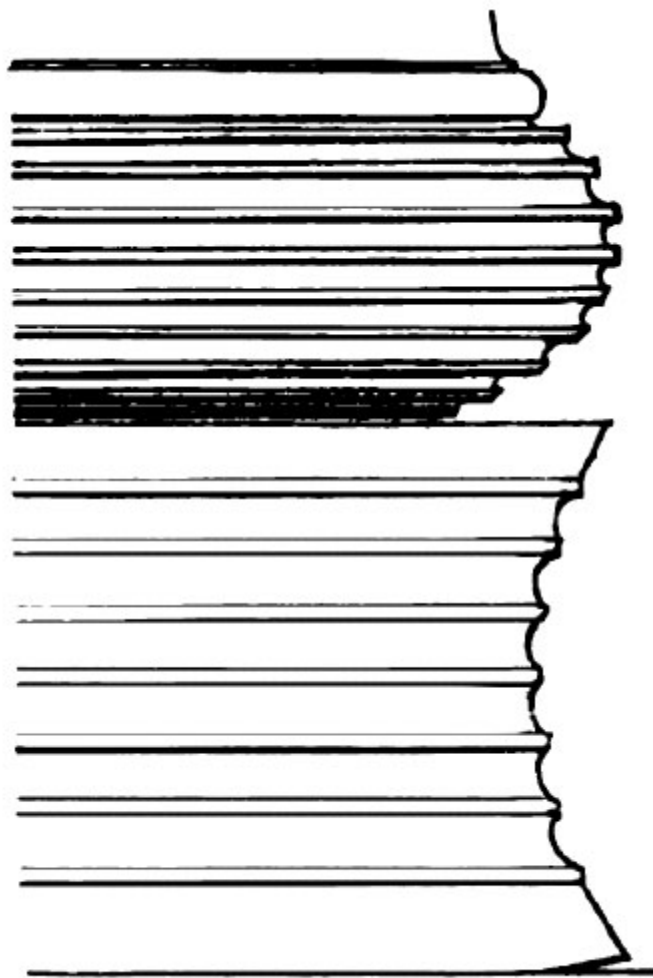

Bible History Online

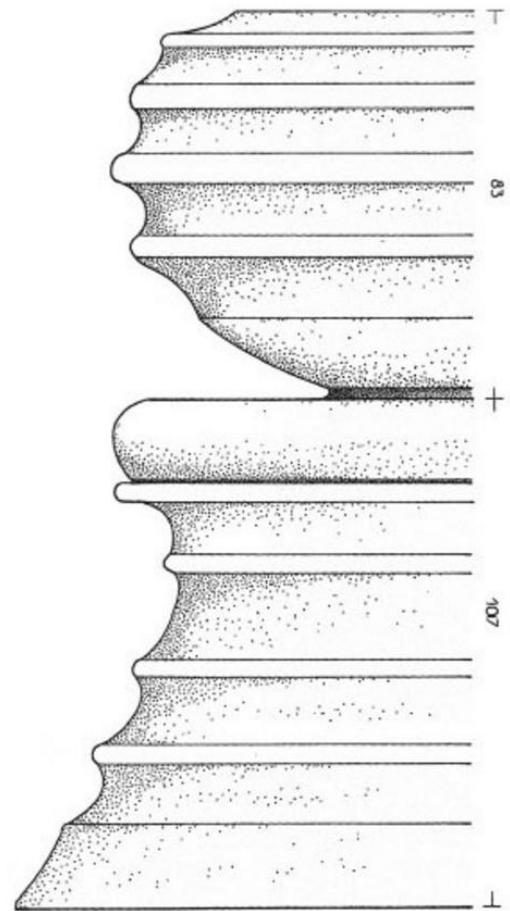

# EPHESOS

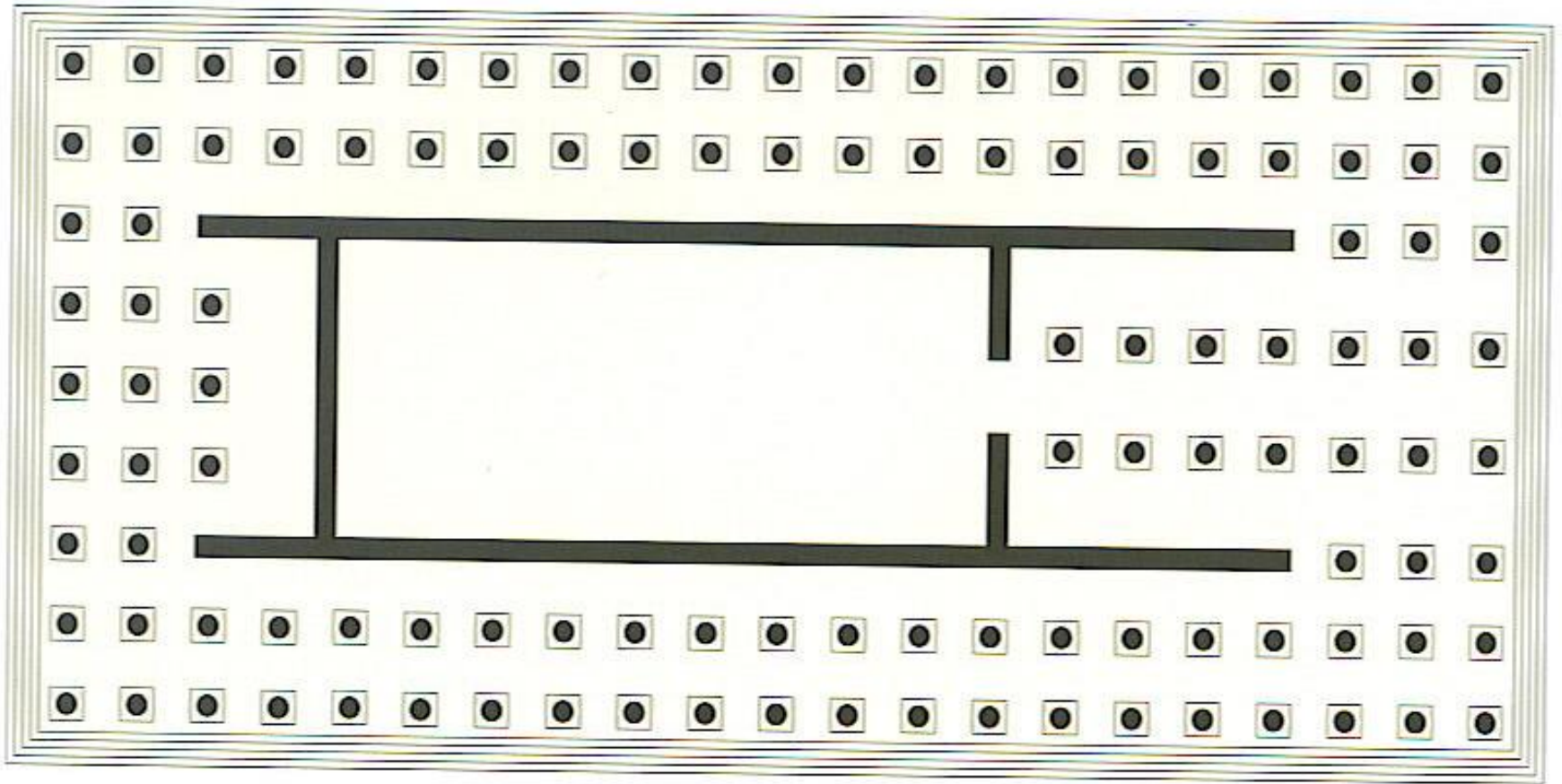

ARCHAIC TEMPLE ARTEMIS (550-460 B.C.  
ARCHITECTS: Χερσίφρων, Μεταγένης, Θεόδωρος  
PLINY: 127 COLUMNS

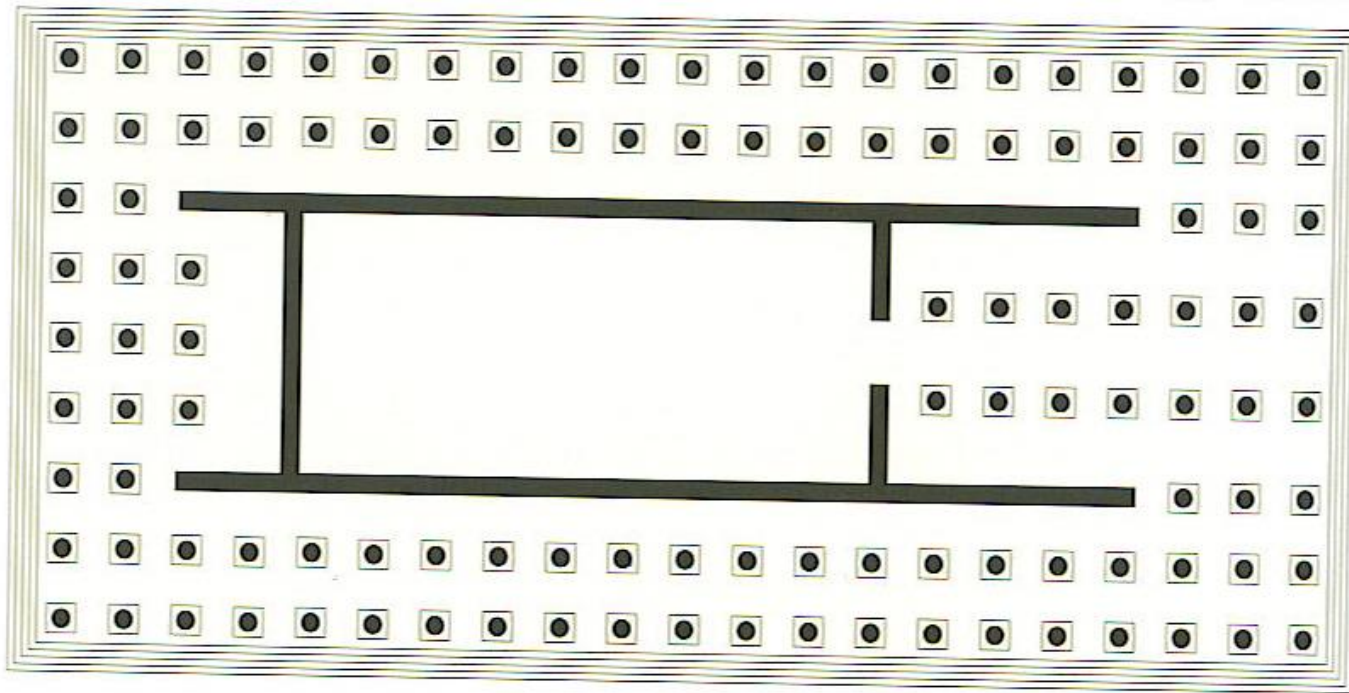

ARTEMIS TEMPLE  
EPHESOS  
550 B.C.

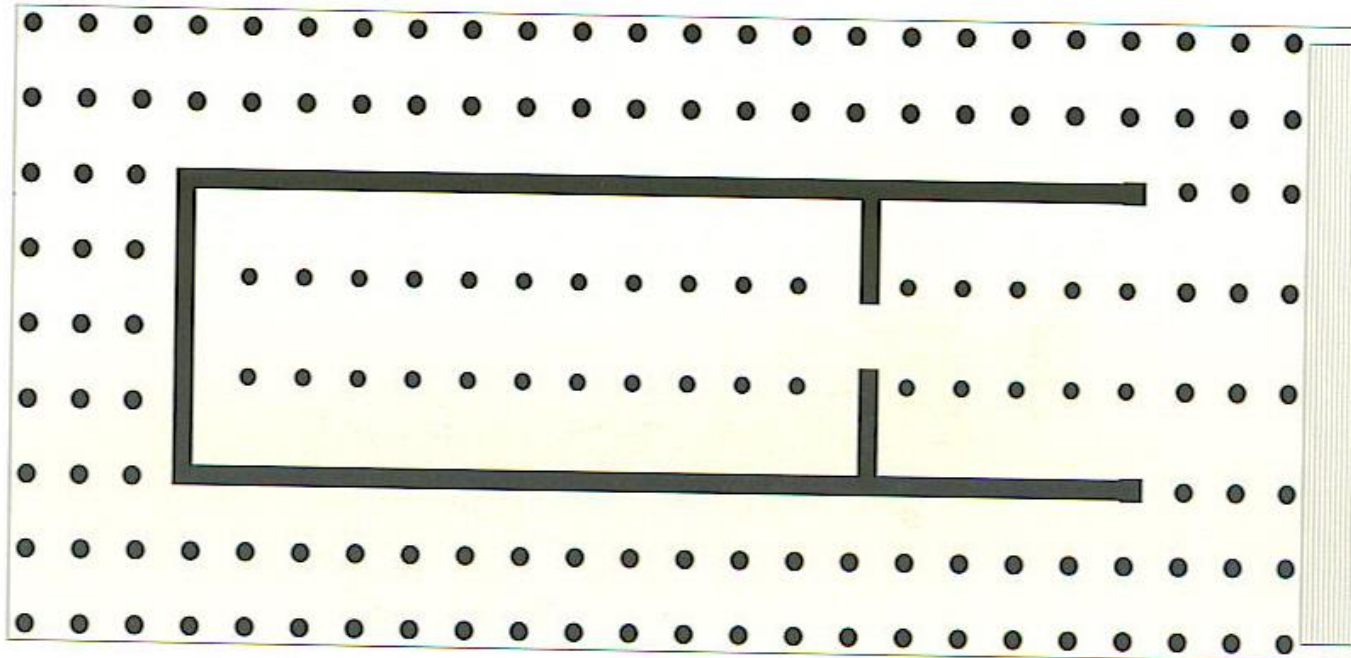

HERA TEMPLE IV  
(Πολυκράτη)  
ON SAMOS. 538 B.C.

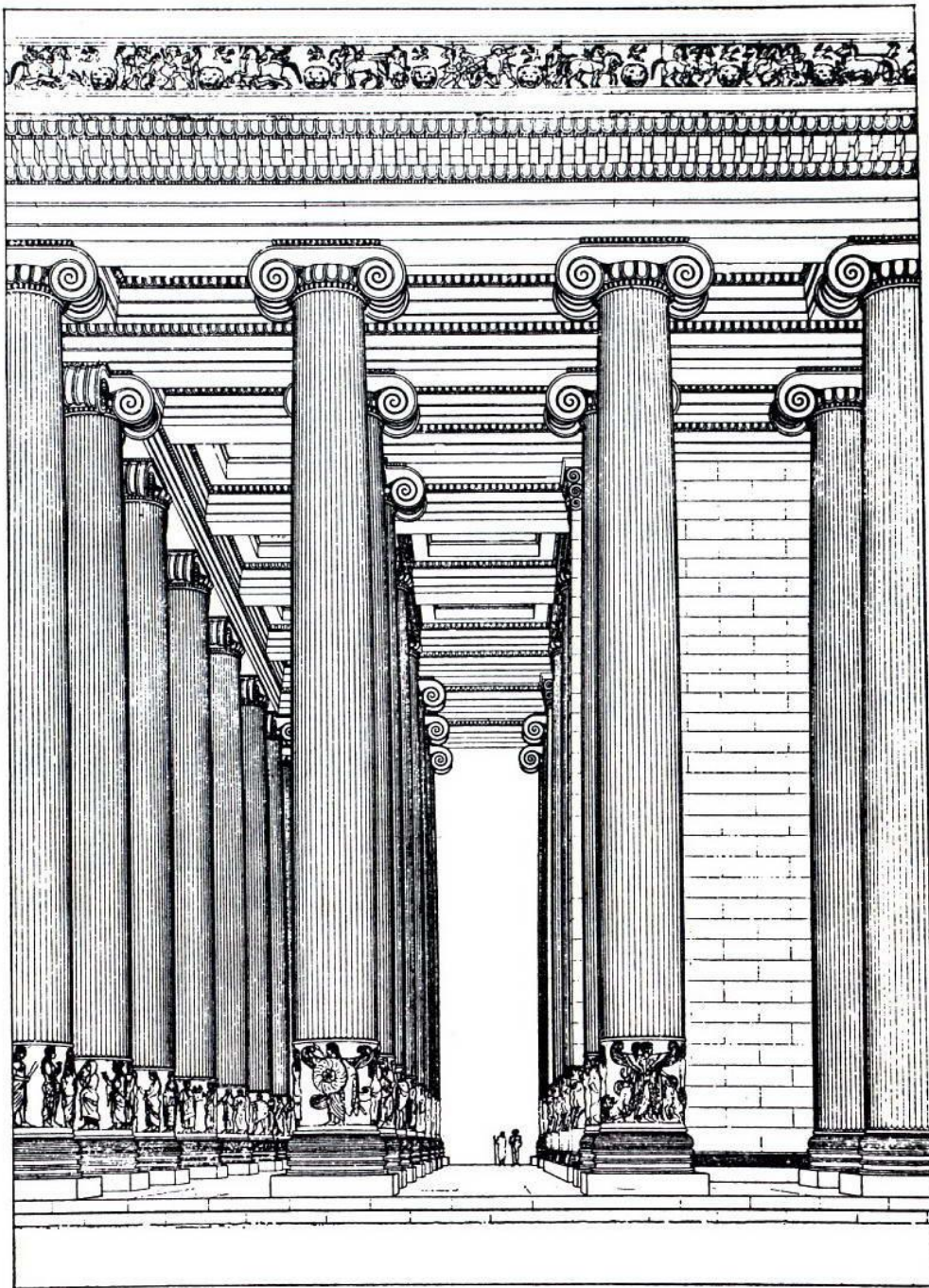

## ΑΡΤΕΜΙΣΙΟ ΕΦΕΣΟΥ

36 columnae caelatae  
(CROESUS 546 π.Χ.)

\*ΗΡΟΣΤΡΑΤΟΣ 356 Π.Χ.

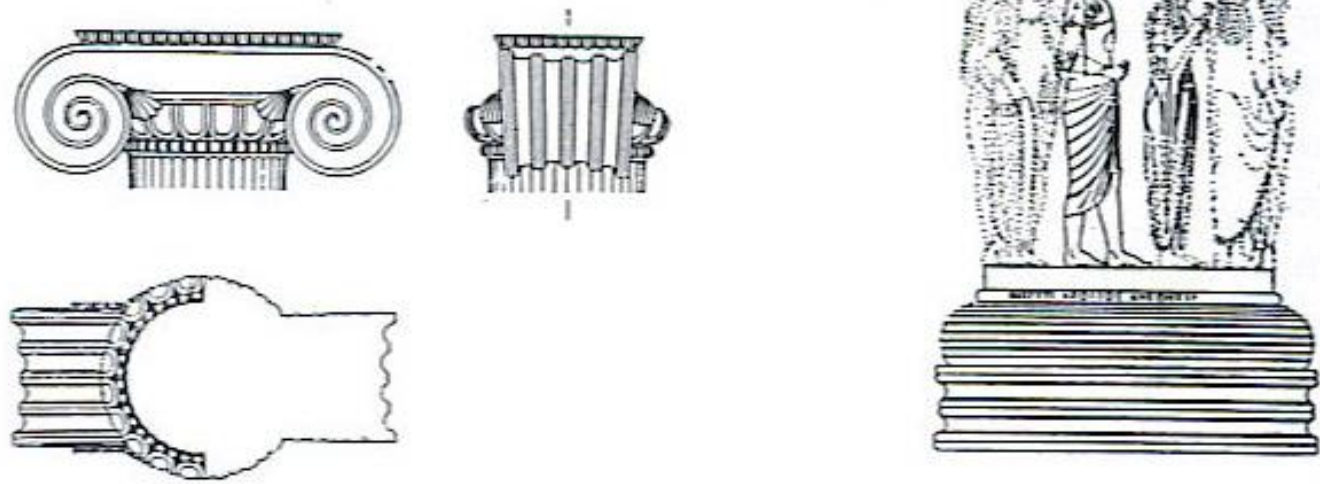

292α,β. Έφεσος, αρχαϊκό Ἀρτεμίσιο. Θραύσμα-  
τα από τους ανάγλυφους κίονες (columnae  
caelatae), Λονδίνο, Βρετανικό Μου-  
σεϊό Β 121, Β 91.

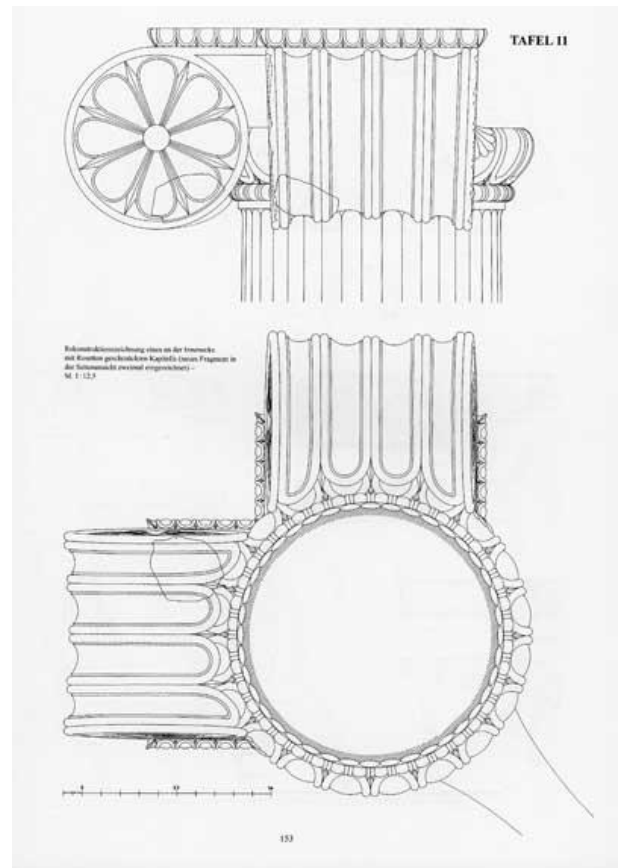

# ARTEMIS EPHEBUS

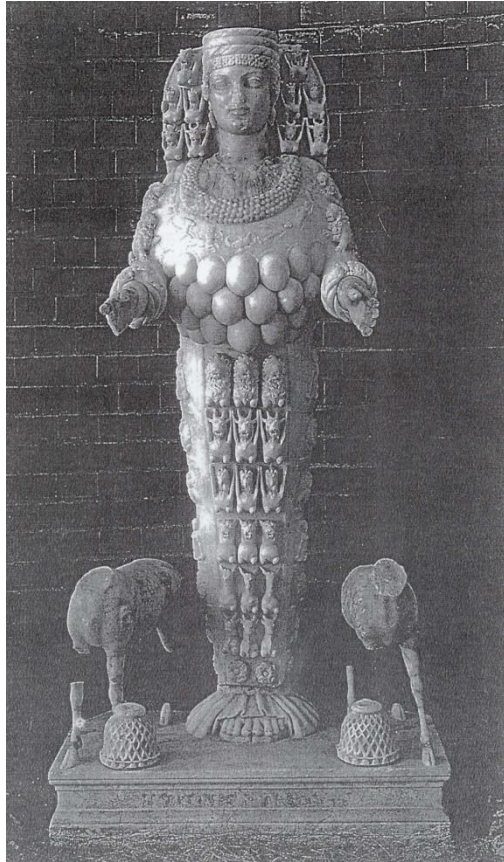

ROMAN COPIES

# DIDYMA MILETOS

APOLLO TEMPLE  
540-525 B.C.

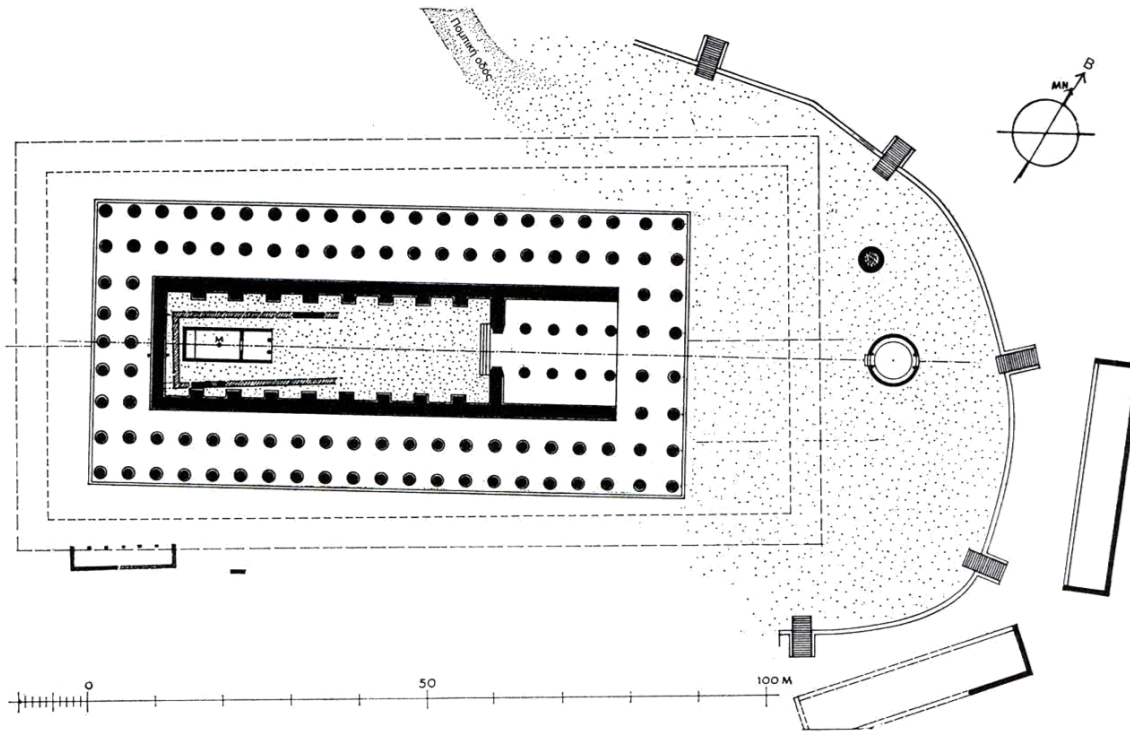



# PEDIMENT?

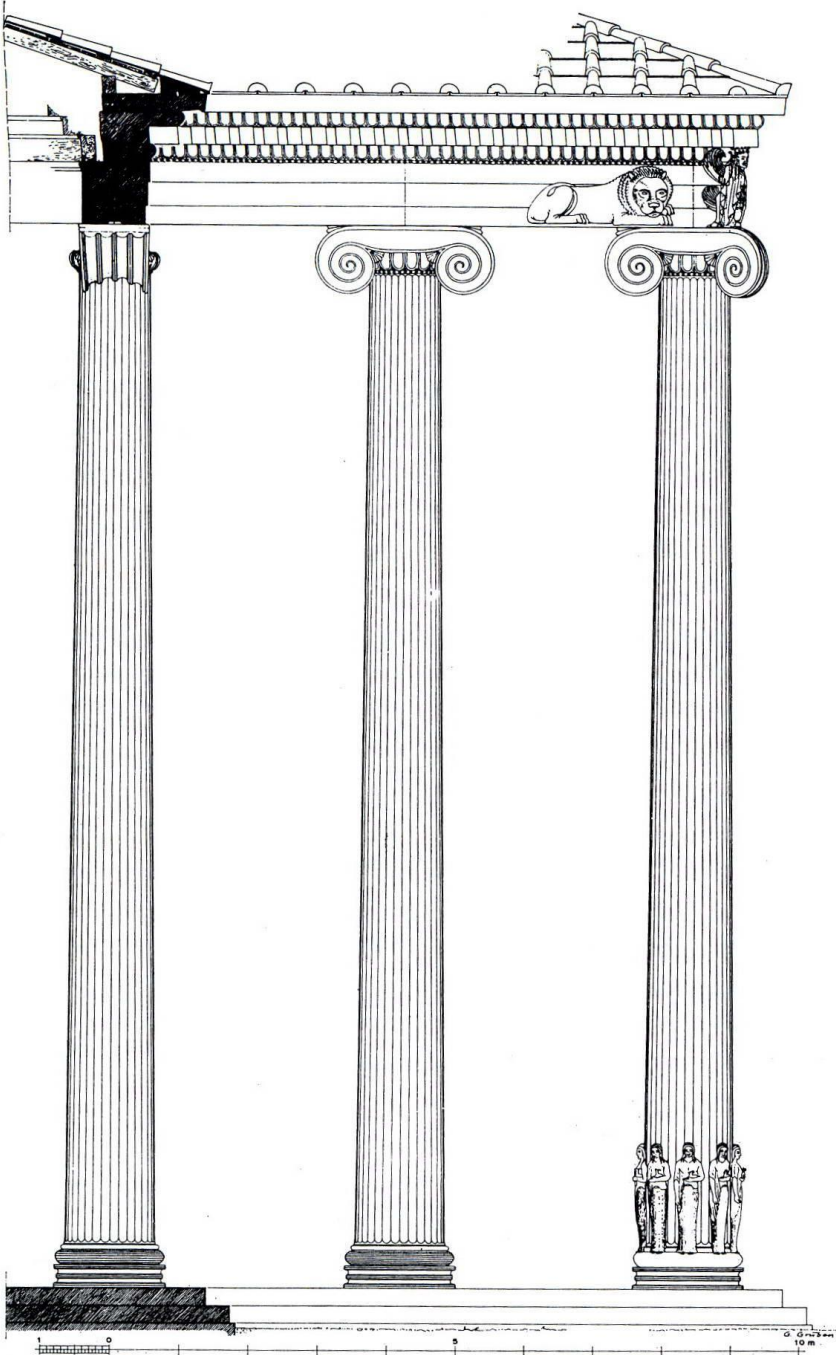

APOLLO MILETOS  
(540-525 π.X.)

# ΙΩΝΙΚΟΙ ΝΑΟΙ (σύγκριση μεγεθών)

HERA TEMPLE IV  
( 530 B.C.)

APOLLO TEMPLE MILETOS  
(540-525 B.C.)

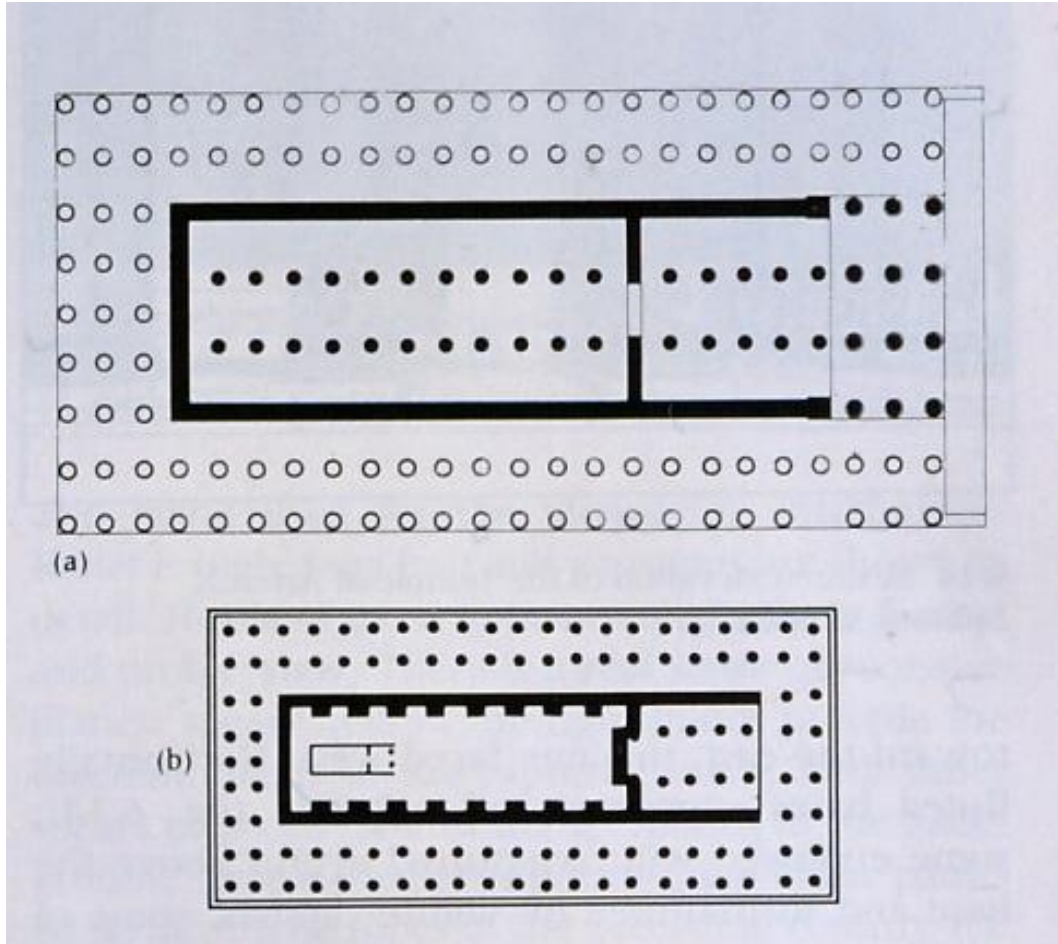



APHRODITE TEMPLE  
(THESSALONIKI)  
500 B.C.

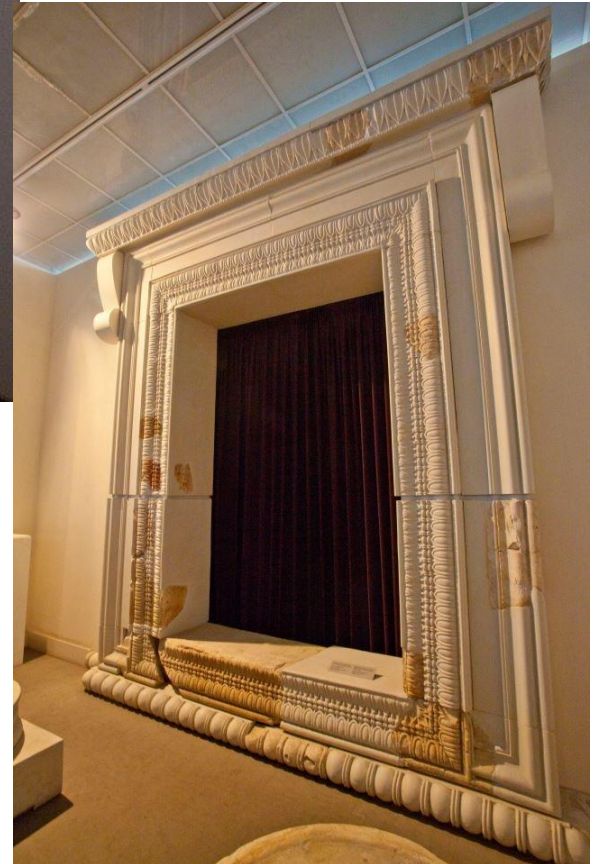



**A.(N.M. 4797), Face A**



**OROPOS CAPITAL. ~ 500 B.C.**

# ΑΡΧΑΪΚΟΙ ΙΩΝΙΚΟΙ ΝΑΟΙ

- ΟΙΚΟΣ ΤΩΝ ΝΑΞΙΩΝ, ΔΗΛΟΣ (590)
- ΝΑΟΣ ΣΤΑ ΥΡΙΑ, ΝΑΞΟΣ (580)
- ΗΡΑΙΟ ΙΙΙ, ΣΑΜΟΣ (570-560)
- ΑΡΤΕΜΙΣ, ΕΦΕΣΟΣ
- ΗΡΑΙΟ ΙV, ΣΑΜΟΣ
- ΑΠΟΛΛΩΝ ΜΙΛΗΤΟΣ (540)
- ΣΑΓΚΡΙ, ΝΑΞΟΣ (540-530)
- ΝΑΟΣ ΔΗΛΙΟΥ ΑΠΟΛΛΩΝΑ, ΝΑΞΟΣ (530)

# ΤΟ ΙΕΡΟ ΤΟΥ ΑΠΟΛΛΩΝΑ ΣΤΗ ΔΗΛΟ

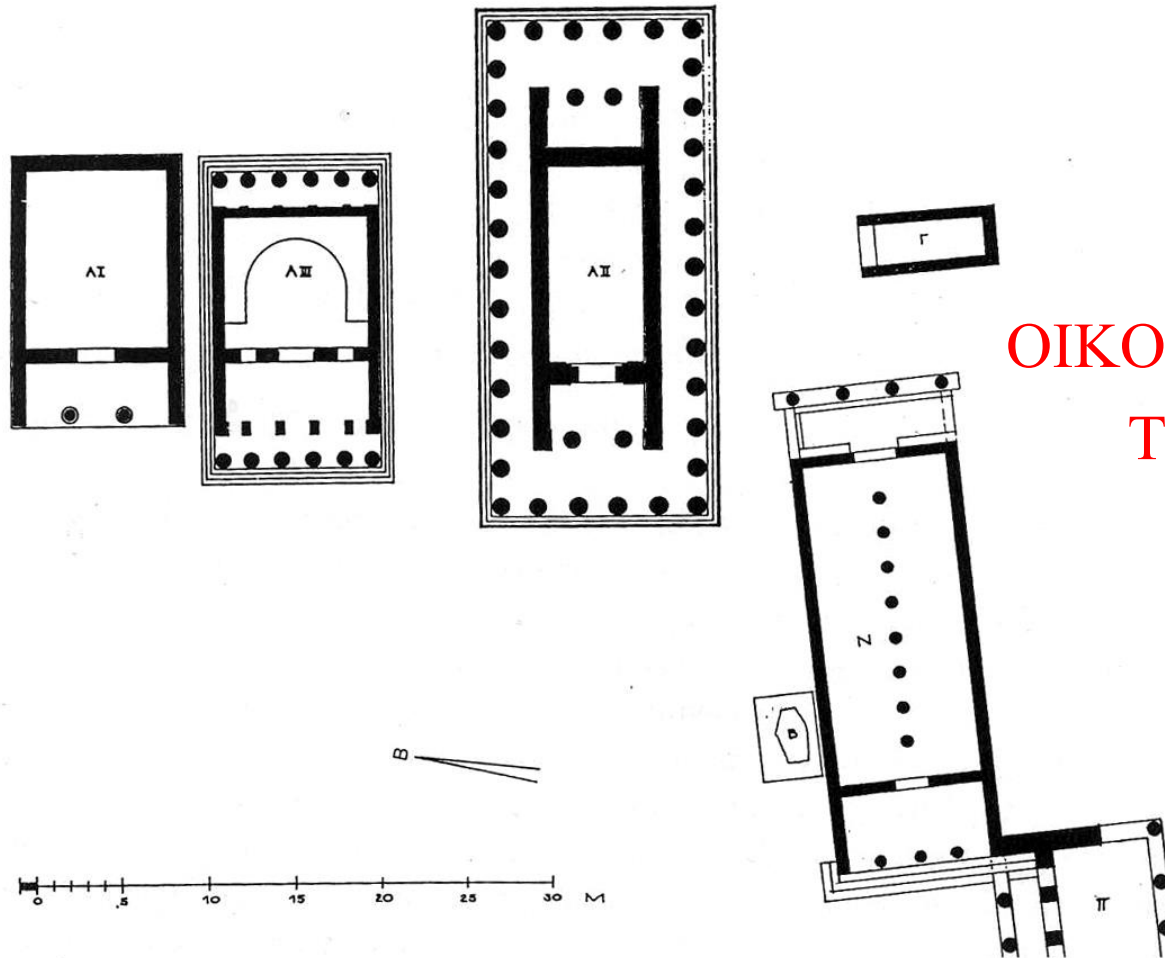

## ΟΙΚΟΣ ΚΑΙ ΠΡΟΠΥΛΟ ΤΩΝ ΝΑΞΙΩΝ

137. Δήλος, ναοί στο ιερό του Απόλλωνα (1:800). Α Ι πρώτος ναός του Απόλλωνα, 530-510 π.Χ.· Α ΙΙ δεύτερος ναός του Απόλλωνα, άρχισε μετά το 478 π.Χ. και ολοκληρώθηκε μετά το 303 π.Χ.· Α ΙΙΙ τρίτος ναός του Απόλλωνα (λεγ. ναός των Αθηναίων), 425-417 π.Χ., Γ μυκηναϊκός-γεωμετρικός ναός (;)· Ν Οίκος των Ναξίων, α' τέταρτο του αιώνα π.Χ.· Β Απόλλωνας των Ναξίων, 600 π.Χ.· Π Πρόπυλο.

- ΔΥΤΙΚΗ ΠΡΟΣΤΑΣΗ. ΠΡΟΣΤΕΘΗΚΕ ΠΡΟΣΤΩΟ ΑΝΑΤΟΛΙΚΑ







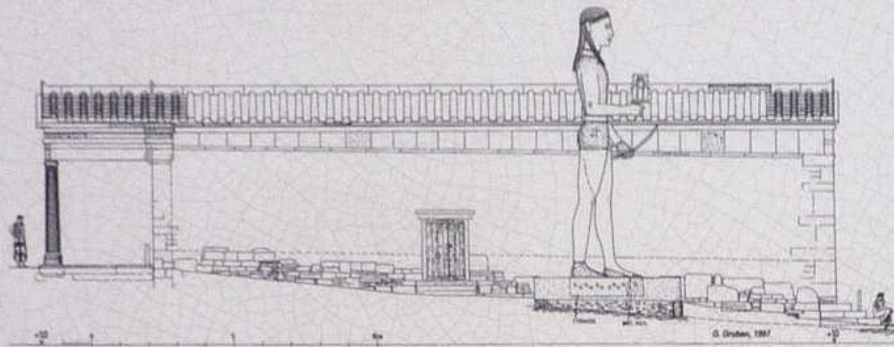
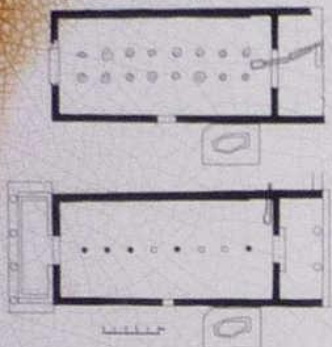

Ο Οίκος και ο Κολοσσός των Ναξίων

The Oikos and the Colossus of the Naxians

Ο Οίκος των Ναξίων οικοδομήθηκε στις αρχές του 6<sup>ου</sup> αι. με μεγάλους γρανιτόλιθους. Ο πρόδομος, στη δυτική πλευρά, είχε δύο κίονες εν παραστάσει, δηλαδή μεταξύ προεκτάσεων των μακρών τοίχων του κτηρίου. Στα μέσα του 6<sup>ου</sup> αιώνα προστέθηκε μια δεύτερη είσοδος στην ανατολική όψη με μαρμάρινο προστώο. Η δικλινής μαρμάρινη στέγη στηριζόταν σε οκτώ λεπτούς ιωνικούς κίονες που διαιρούσαν το εσωτερικό του κτηρίου σε δύο κλίτη. Για τη χρήση του κτηρίου έχουν διατυπωθεί κατά καιρούς διαφορετικές θεωρίες: ότι ήταν ο αρχαιότερος ναός του Απόλλωνα, ότι χρησιμοποιήθηκε για τη φύλαξη ιερών σκευών και αναθημάτων, ή ως εστιατόριο.

Εξωτερικά της ΒΔ γωνίας του κτηρίου σώζεται η πελώρια μαρμάρινη βάση, βάρους περίπου 32 τόνων, πάνω στην οποία υψωνόταν ο Κολοσσός των Ναξίων, ένα τεράστιο άγαλμα του Απόλλωνα, ύψους 9 περίπου μέτρων, των αρχών του 6<sup>ου</sup> αι. π.Χ. Ο θεός παριστανόταν στον τύπο των κούρων, γυμνός, κατ' ενώπιον, με μακριά μαλλιά, σπιθαρούς ώμους, και το αριστερό πόδι λίγο πιο μπροστά από το δεξί. Πιθανόν στα χέρια του κρατούσε τόξο και βέλη, ή τις τρεις Χαριτίδες. Στα κομμάτια που σώζονται διατηρούνται οι τρύπες για τη στερέωση των χάλκινων μαλλιών και της χάλκινης ζώνης. Τα λαμπερά μαλλιά του θεού ήταν ορατά από το πέλαγος, στη βάση του κατέλιγε η πλατιά λεωφόρος των Λεόντων κι εδώ αλακλήρωνόταν το μακρύ ταξίδι των προσκυνητών. Ακόμα κι όταν το Ιερό κατακλύστηκε από κτήρια το κεφάλι του Απόλλωνα ήταν ορατό από παντού. Όπως αναφέρει ο Πλούταρχος, οι δυνατοί βοριάδες του Αιγαίου έριξαν κάποτε τον χάλκινο φοίνικα του Νικία πάνω στο άγαλμα, που σωριάστηκε στο έδαφος. Οι Νάξιοι το έσπασαν και πάλι στη βάση του και τότε φαίνεται πως χάραξαν την νεότερη επιγραφή της δυτικής πλευράς: ΝΑΞΙΟΙ ΑΡΟΛΛΩΝΙ. Η επιγραφή στην ανατολική πλευρά της βάσης είναι μία από τις αρχαιότερες ελληνικές επιγραφές: "ΤΟ ΑΥΤΟ ΛΙΘΟ ΕΜΙ ΑΝΔΡΙΑΣ ΚΑΙ ΤΟ ΣΦΕΛΑΣ", δηλαδή "είμαι από τον ίδιο λίθο άγαλμα και βάση". Το 1445 ο Κυριακάς ο Ανκωνίτης σχεδίασε τα σωζόμενα τμήματα του κολοσσού, ο οποίος, σύμφωνα με το σχέδιο του Κυριακού, ήταν στραμμένος προς το βορά, αντικρίζοντας τους προσκυνητές που κατέβαιναν στο λιμάνι του Σκαρδανά και διέσχισαν τη λεωφόρο των Λεόντων για να καταλήξουν στην βάση του και τον Κερατώνα. Γύρω στο 1675 ένας Άγγλος καπετάνιος, ή ο Βενετός διοικητής της Τήνου έκοψε το κεφάλι του, το οποίο από τότε έχει εξαφανιστεί. Κάποτε προσπάθησαν να μεταφέρουν τα υπόλοιπα τμήματα χωρίς να τα καταφέρουν εξαιτίας του βάρους και τα εγκατέλειψαν μπροστά στο Αρτεμίσιο. Εκεί βρίσκονται σήμερα ο κορμός και η λεκάνη του αγάλματος, στο Βρετανικό Μουσείο είναι ένα τμήμα του αριστερού ποδιού, ενώ το αριστερό του χέρι είναι στο Μουσείο Δέλου.

The Oikos of the Naxians was built in the early 6<sup>th</sup> BC. cent. of large granite blocks. The west entrance had two columns between the ends of the long walls. During the mid-6<sup>th</sup> century BC., a second entrance with a marble porch was added on the east façade. The pitched marble roof was supported by eight slim Ionian columns. There are different theories about the use of the building: some hold that it was the earliest temple of Apollo, others that it was used to store sacred vessels and votive offerings, or yet others that it was a dining hall.

Outside the northwest corner of the building is the huge marble base weighing approximately 32 tons that supported the towering Colossus of the Naxians, a statue of Apollo approximately 9 metres in height, dating to the early 6<sup>th</sup> cent. BC. The god was depicted in the kouros type, nude, frontally, with long hair, sturdy shoulders, and the left foot placed slightly in front of the right. In his hands he held either a bow and arrows, or the Three Graces. The surviving pieces bear the holes that served to fasten the statue's bronze locks and belt. The god's bright hair was visible from the sea, and the broad Avenue of the Lions ended at its base. Even when the Sanctuary was covered with buildings, the head of Apollo was visible from all sides. According to Plutarch, the bronze palm tree dedicated by Nicias fell over and knocked down the statue. The Naxians restored it to its base and it was apparently then that they inscribed the west side of the base: To Apollo from the Naxians. The east side bears one of the earliest Greek inscriptions: "statue and base, I am made of the same stone." In 1416 the Florentine Cristoforo Buondelmonti reports that he and his comrades attempted to raise the colossus: "we also saw upon a plain on Delos an old sanctuary constructed of many columns and a huge statue fallen upon the ground, so enormous that though we were over a thousand men and had all the equipment and ropes from our ships we were unable to raise it. Thus we despaired and left it at the same location." In 1445 Cyriacus of Ancona sketched the surviving sections of the colossus which, according to the sketch, was facing north looking towards the pilgrims who disembarked in Skardanas bay and walked down the Avenue of the Lions to reach its base and Keraton, the final point of their pilgrimage. Around 1675, either a British captain, or the Venetian Governor of Tinos, cut off its head, all trace of which has since disappeared. At one time an attempt was made to haul away the remaining sections, but was unsuccessful because of their weight, and the parts were abandoned in front of the Artemesion. The statue's torso and pelvis are still there; the British Museum has a section of the left leg, and the Delos Museum has the left hand.

# Ο ΟΙΚΟΣ ΤΩΝ ΝΑΞΙΩΝ. ΔΗΛΟΣ (590)

- ΤΟΙΧΟΙ ΑΠΟ ΓΡΑΝΙΤΗ
- ΚΥΛΙΝΔΡΙΚΕΣ ΒΑΣΕΙΣ
- ΠΛΗΡΗ ΚΙΟΝΟΚΡΑΝΑ
- ΜΑΡΜΑΡΙΝΗ ΣΤΕΓΗ
- ΜΑΡΜΑΡΙΝΗ ΚΕΡΑΜΩΣΗ
- \*ΒΥΖΗΣ

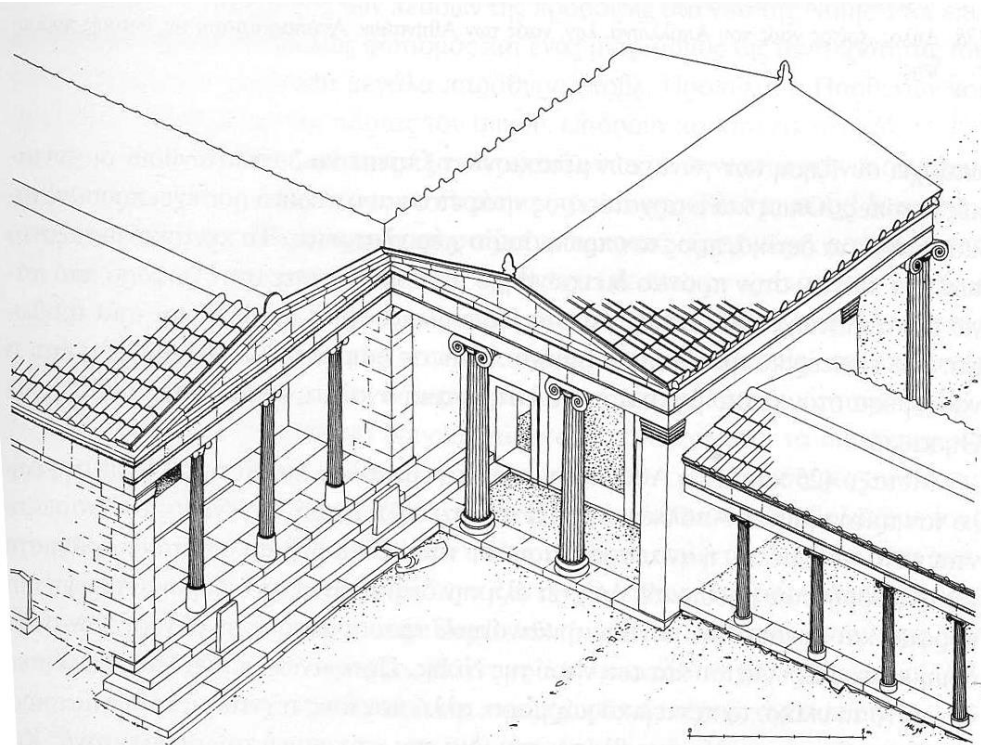

7β. Δήλος, το σύνολο των Ναξίων: Οίκος (590/580 π.Χ.), Πρότυλο (τέλη 6ου αι. π.Χ.) και στοά (540/530). Αναπαράσταση.

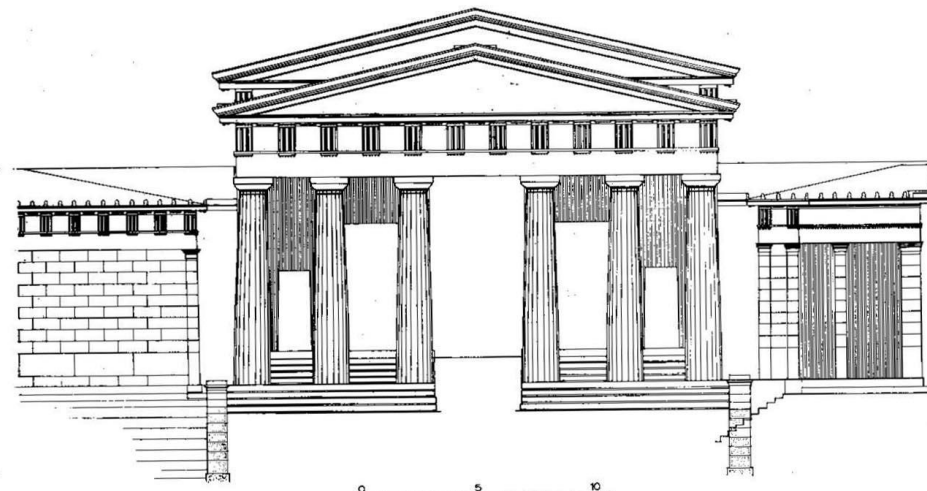
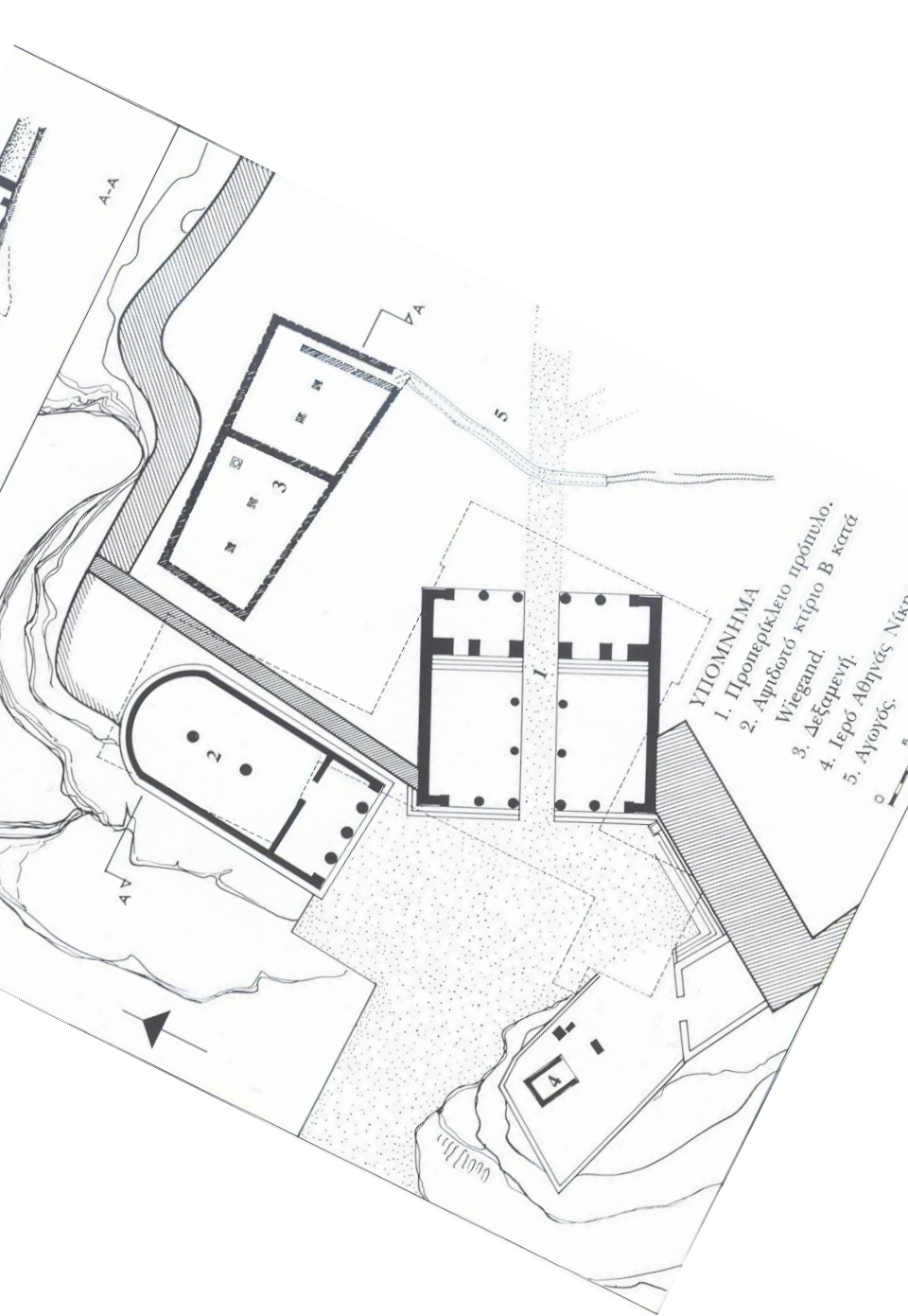

613 The Propylaea flanked by north and south wings. Restored.

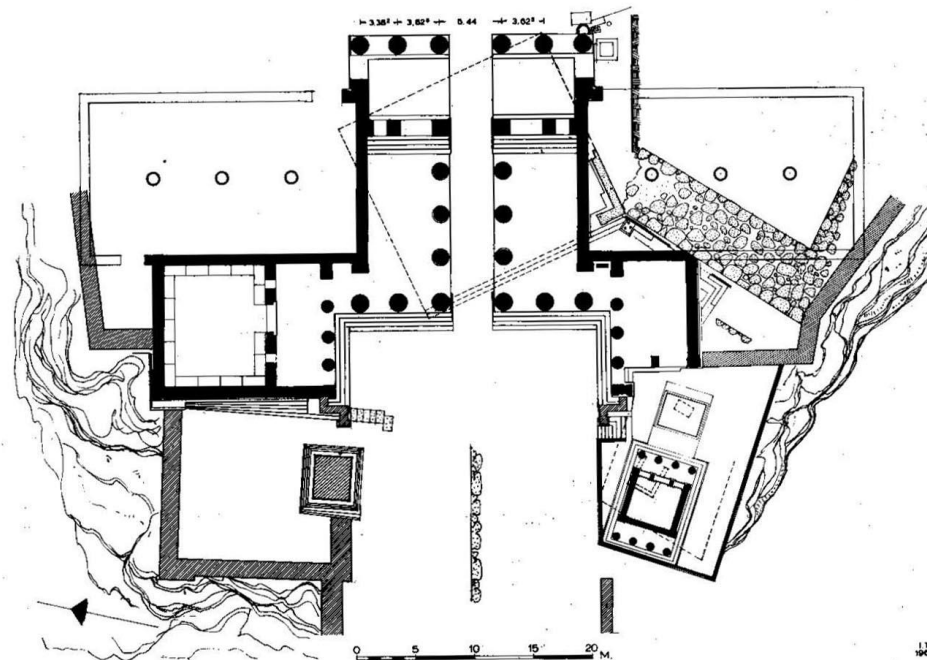

614 The Mnesiklean Propylaea with the temple of Athena Nike and the Agrigga Monument. Broken lines indicate the Old Propylon and the earlier shrine of Athena Nike.

# Ο ΟΙΚΟΣ ΤΩΝ ΝΑΞΙΩΝ. ΔΗΛΟΣ (590)

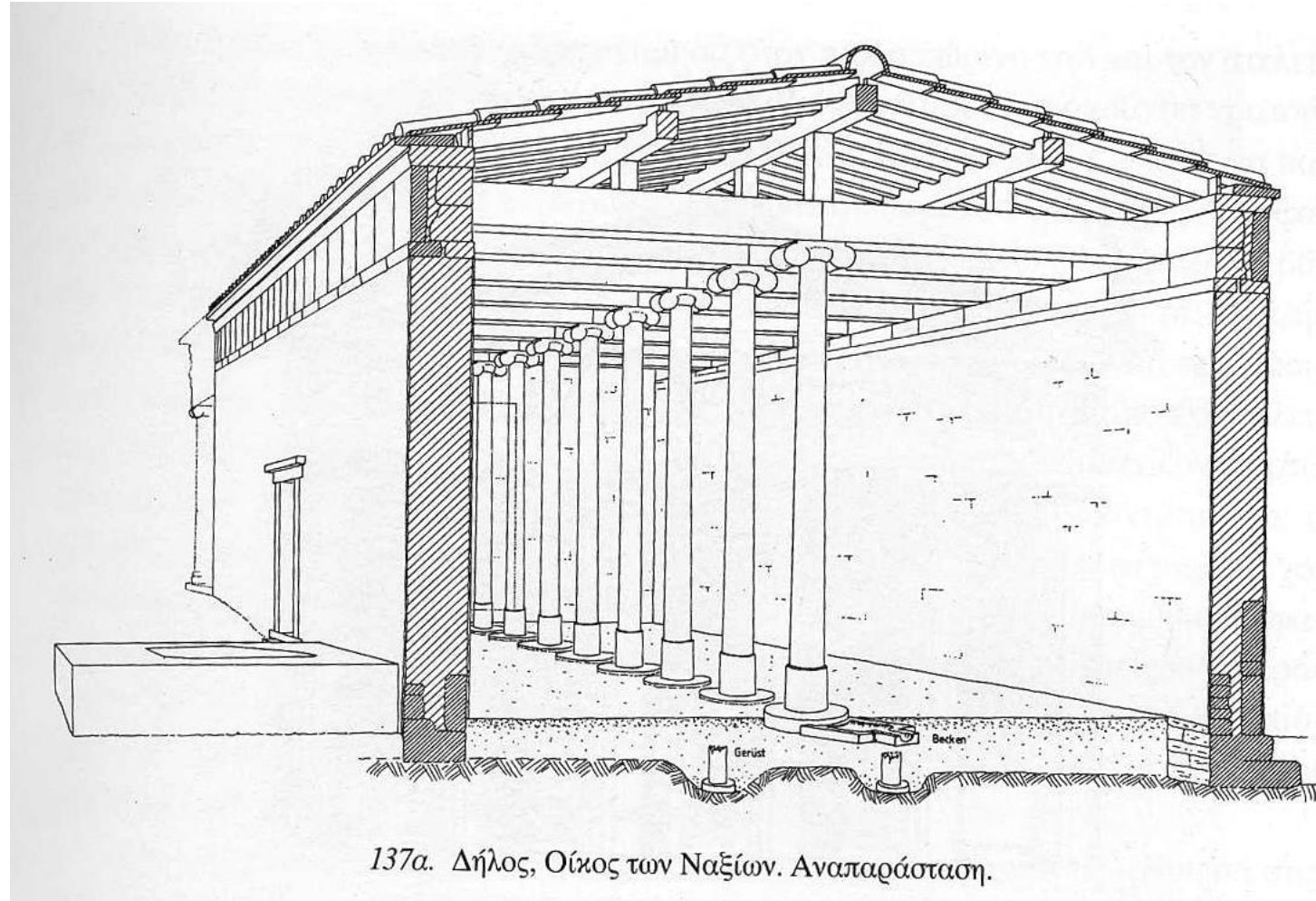

- ΑΡΧΑΙΟΤΕΡΟ ΚΤΙΡΙΟ ? Ή ΒΑΣΕΙΣ ΓΙΑ ΙΚΡΙΩΜΑΤΑ (ΣΚΑΛΩΣΙΕΣ)?
- \* ΑΠΛΗ ΖΩΦΟΡΟΣ ΧΩΡΙΣ ΟΔΟΝΤΕΣ (ΓΕΙΣΗΠΟΔΕΣ)

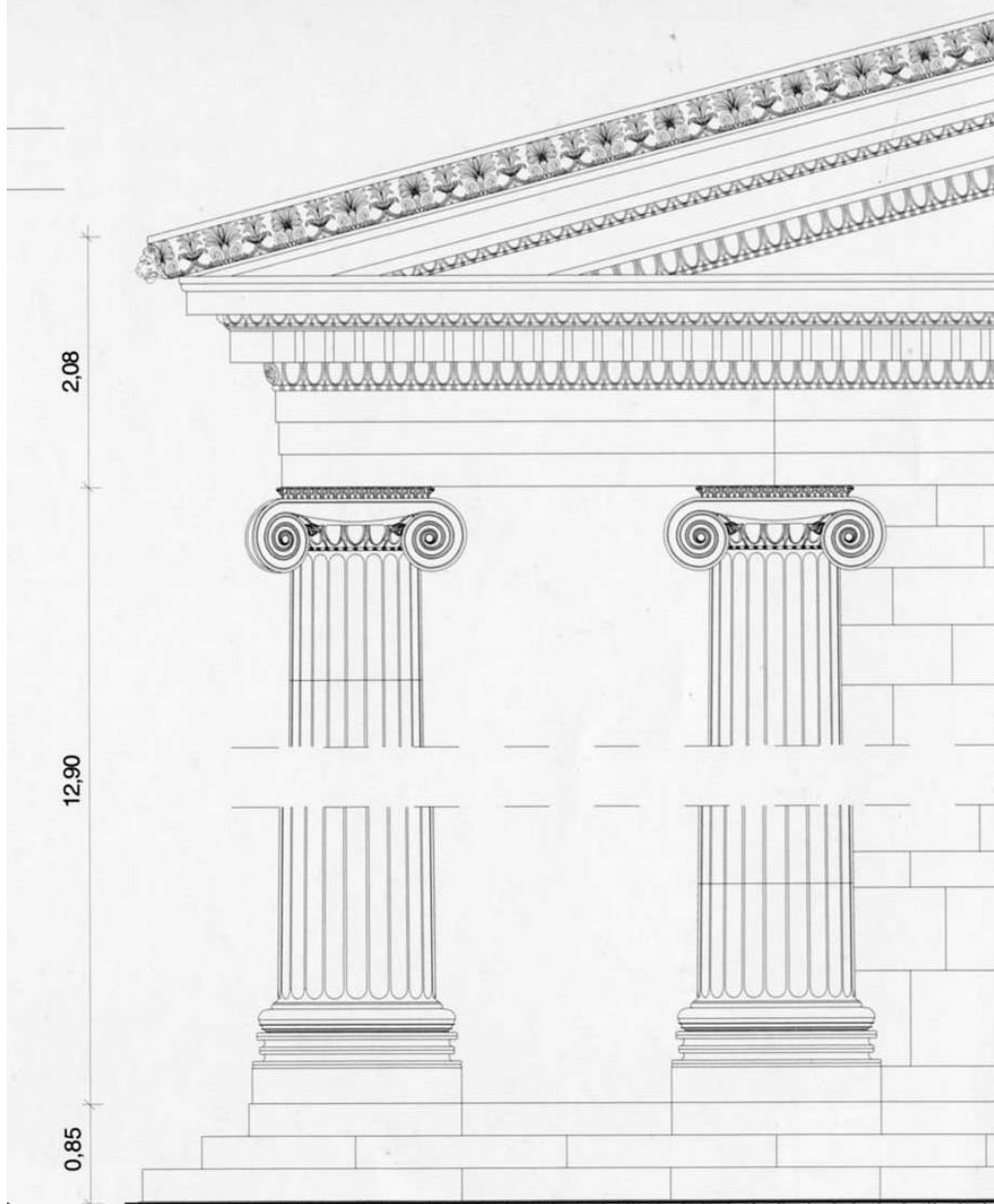

Γεισίποδες

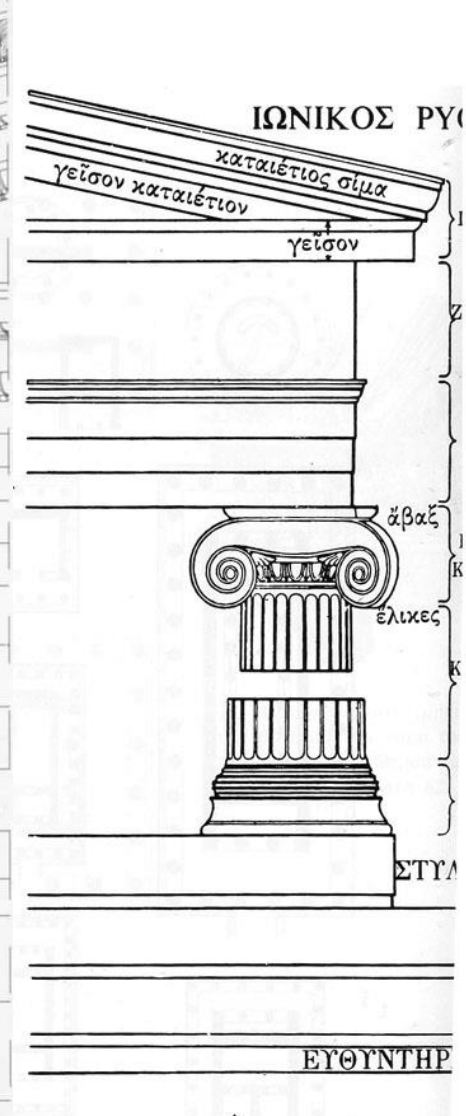

Απλή ζωφόρος

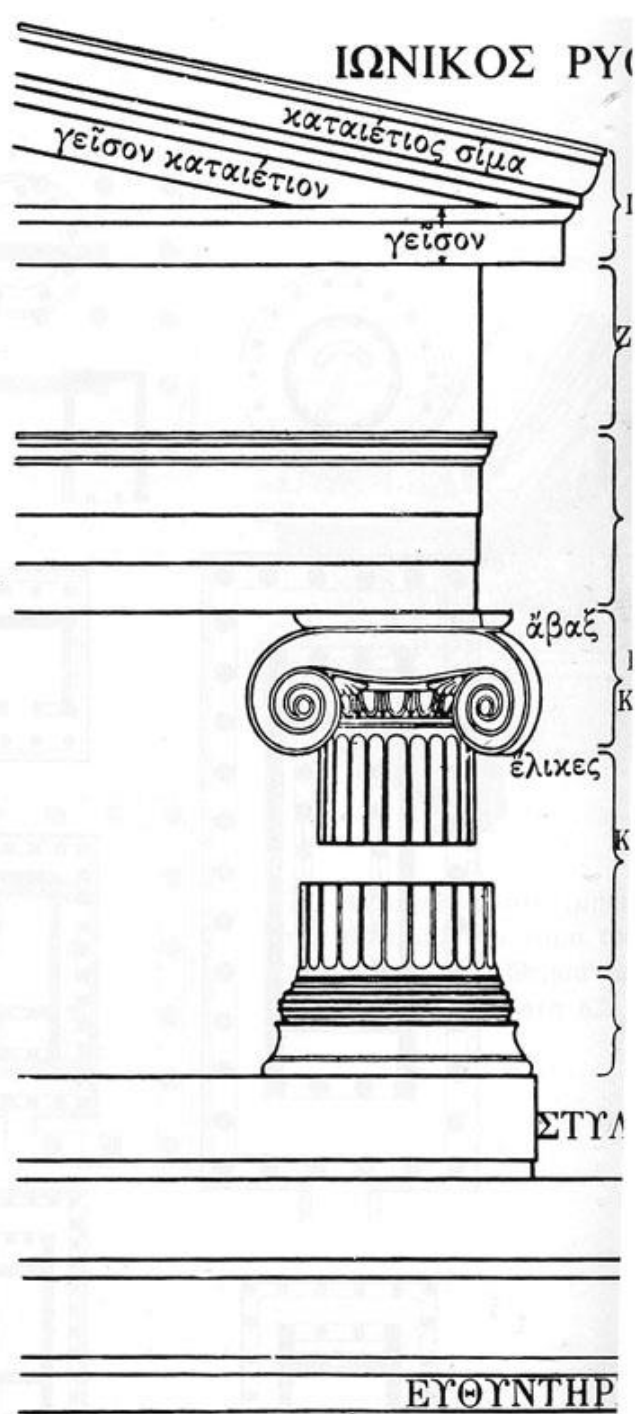
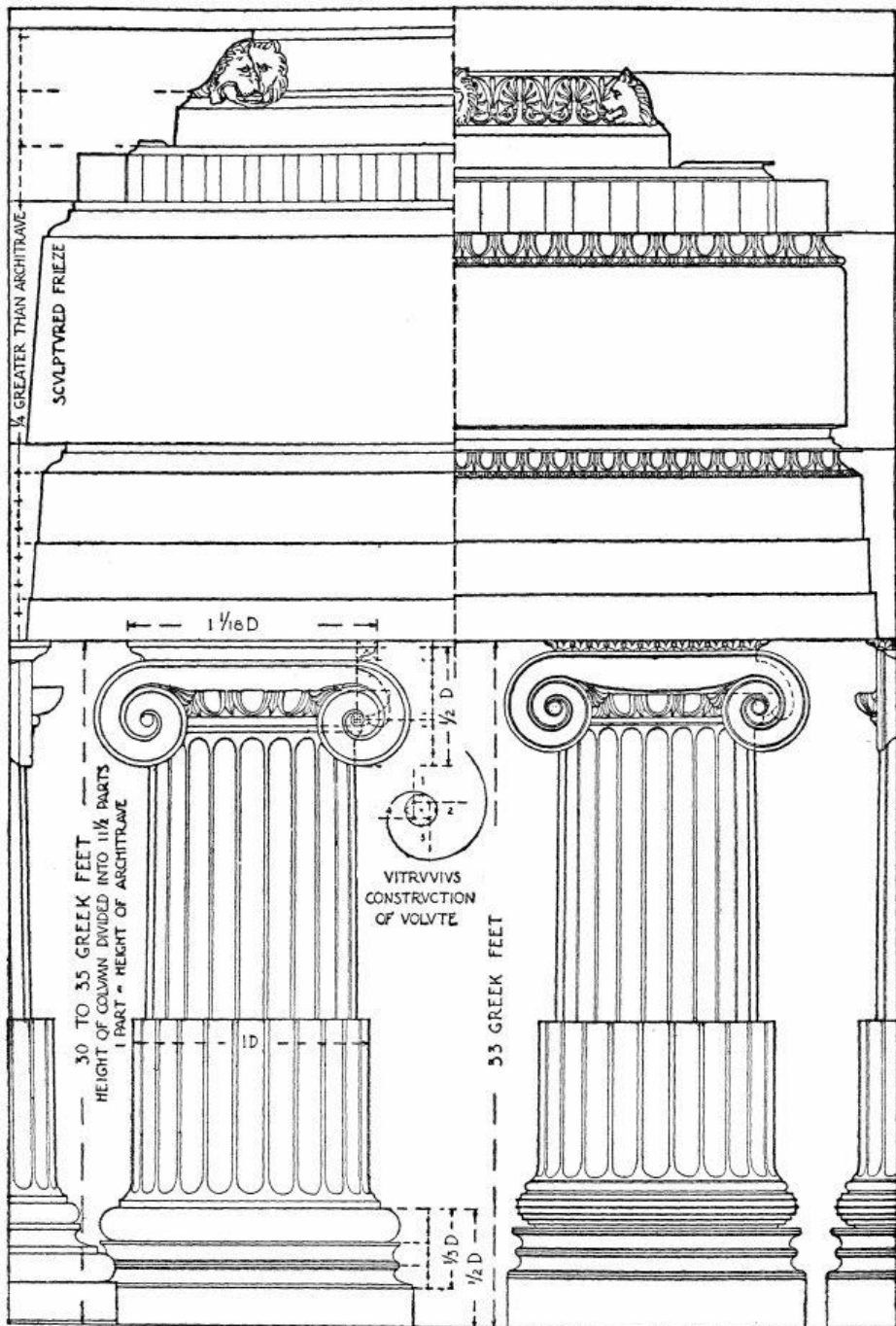

# Η ολομάρμαρη στέγη του Οίκου των Ναξίων στη Δήλο

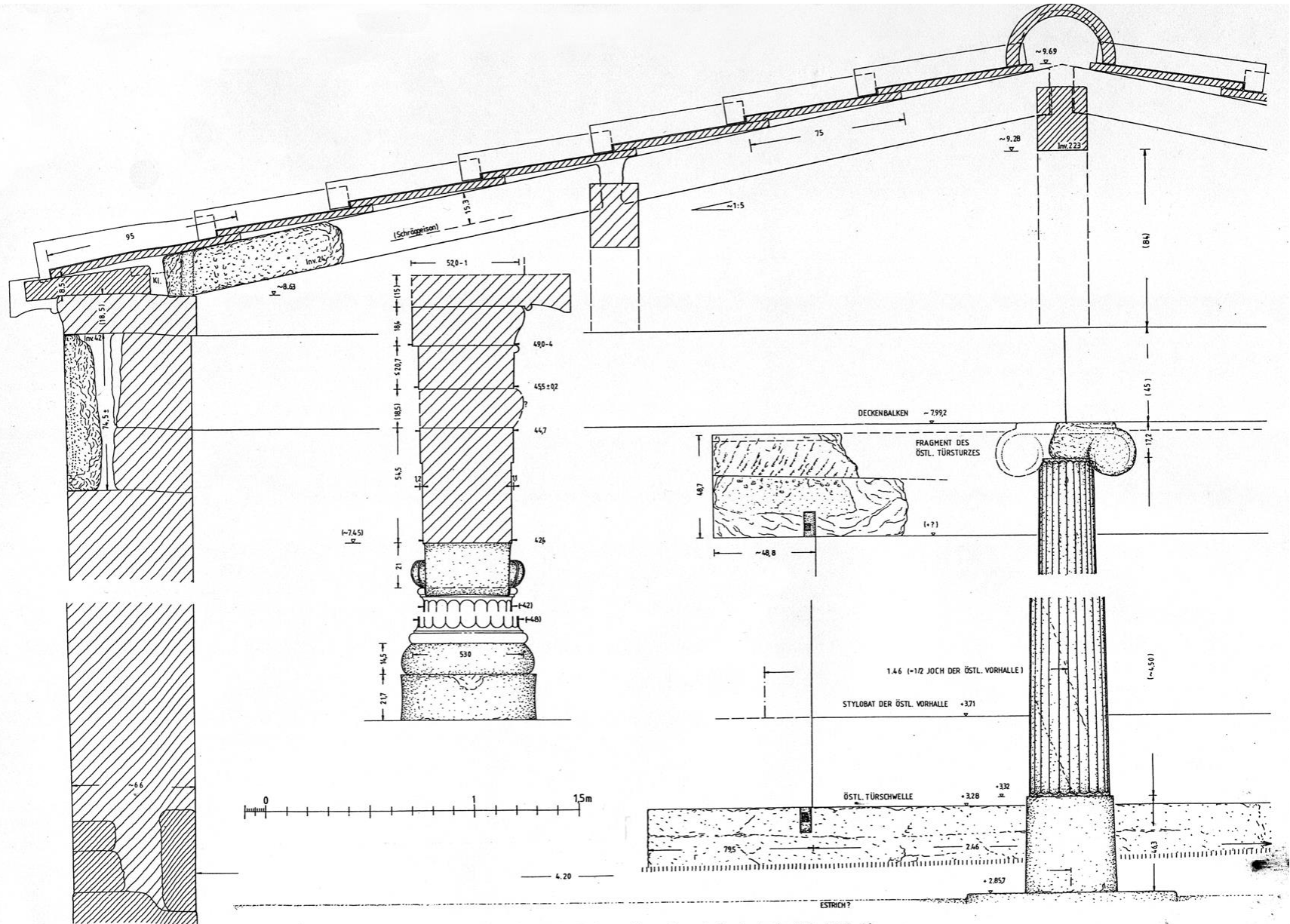

Delos, Oikos der Naxier. Rekonstruierter Querschnitt durch die Cella. M. 1 : 20

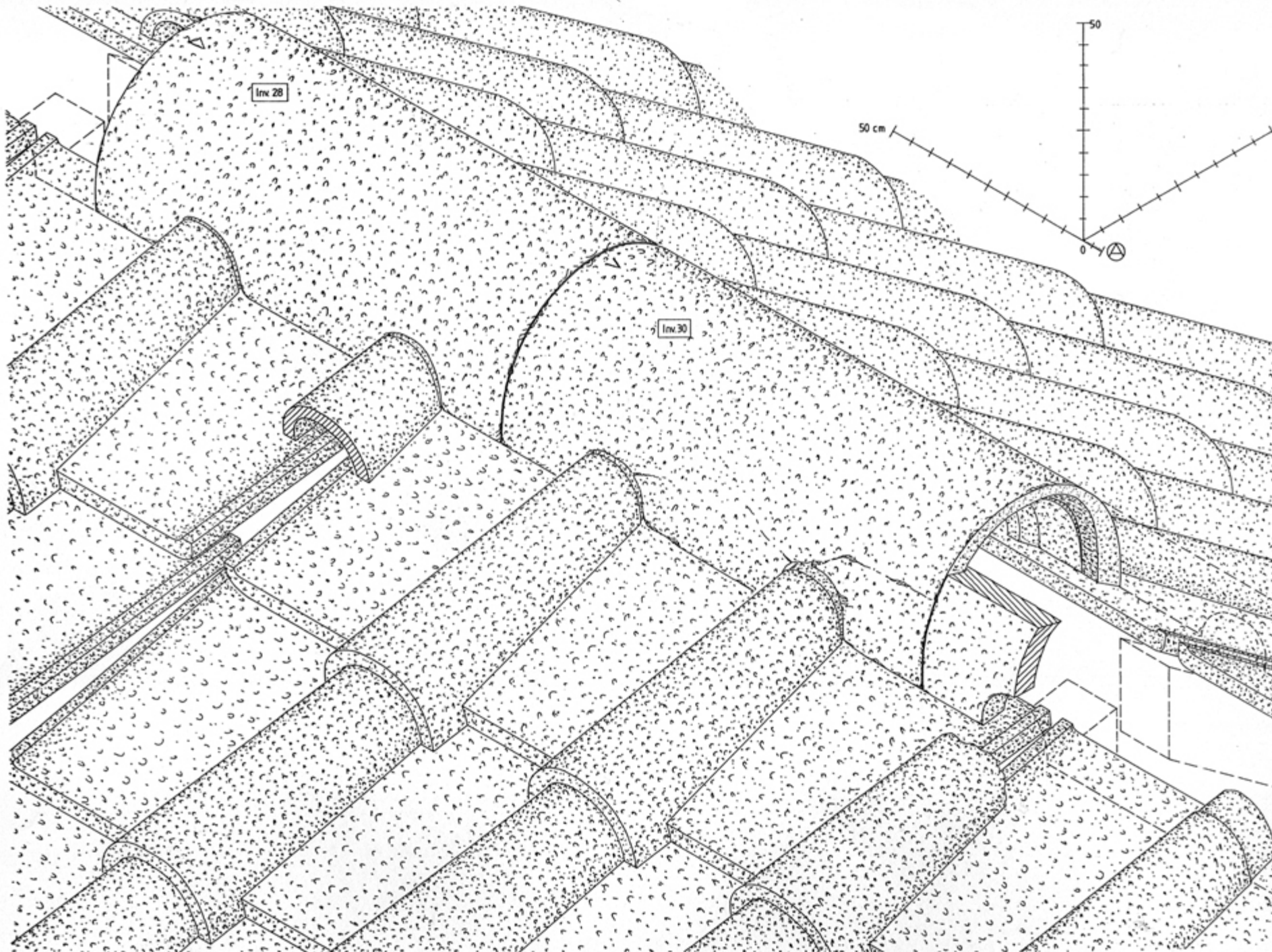



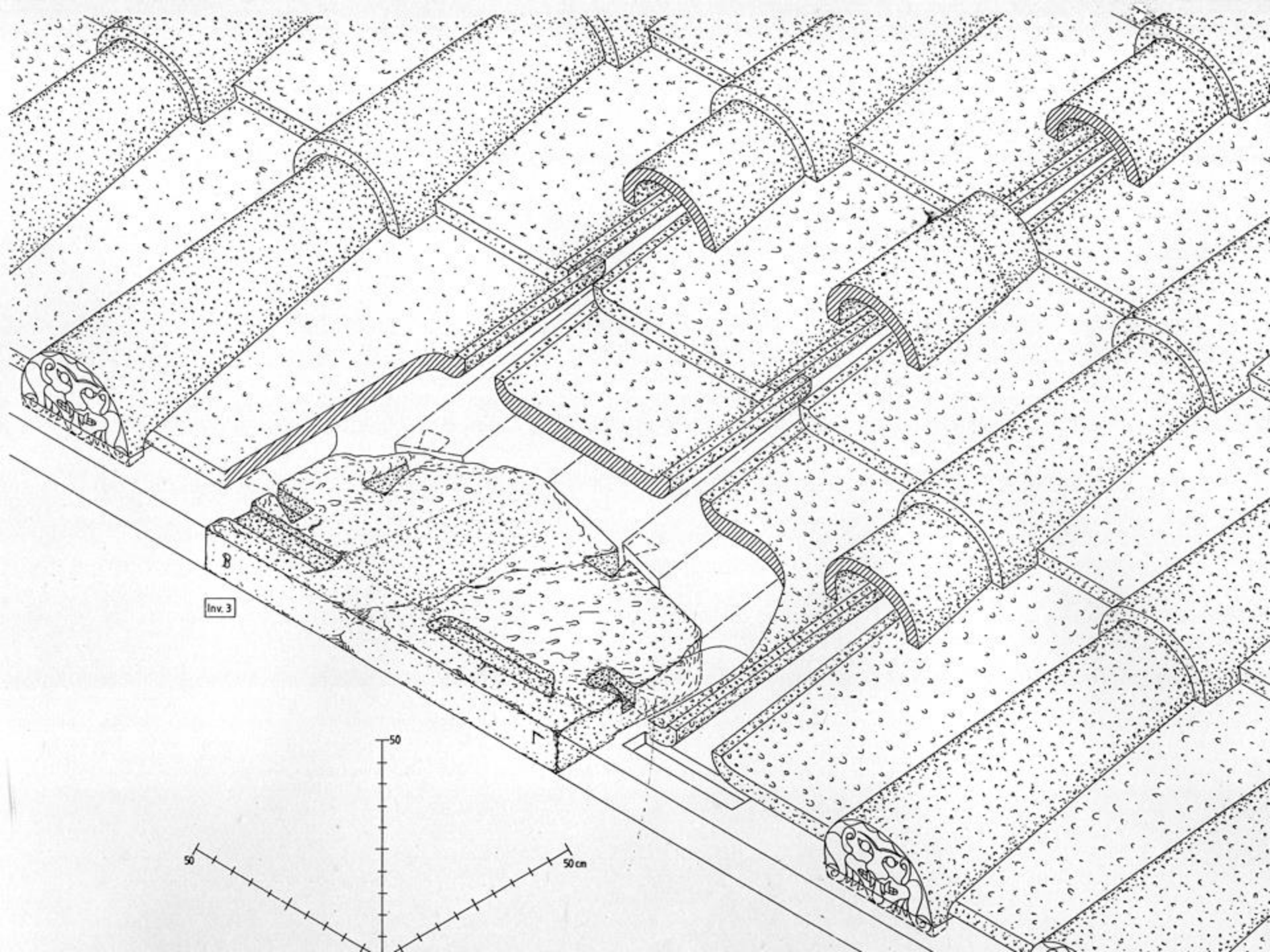

Inv. 3

8

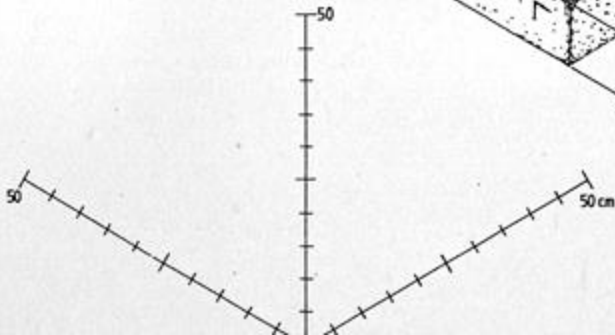





ΔΙΚΟΣ ΝΑΞΙΩΝ  
DIKOS DES NAXIENS

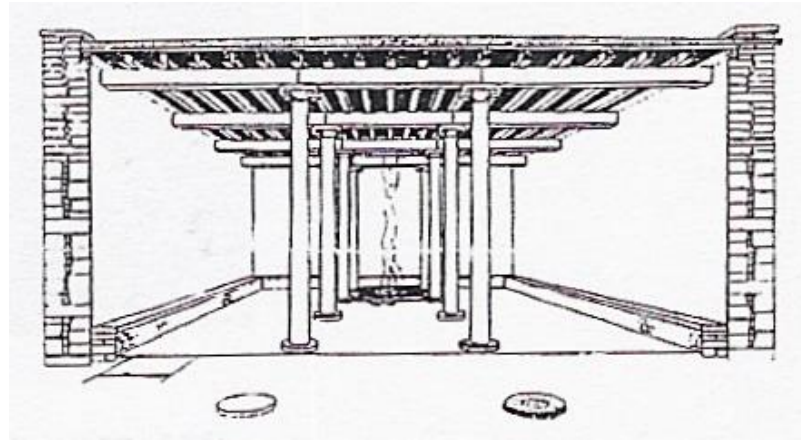

Ναός Ι. ΜΓ  
περίοδος

Ναός ΙΙ. ΥΓ  
περίοδος

Ναός ΙΙΙ. 680 π.Χ.

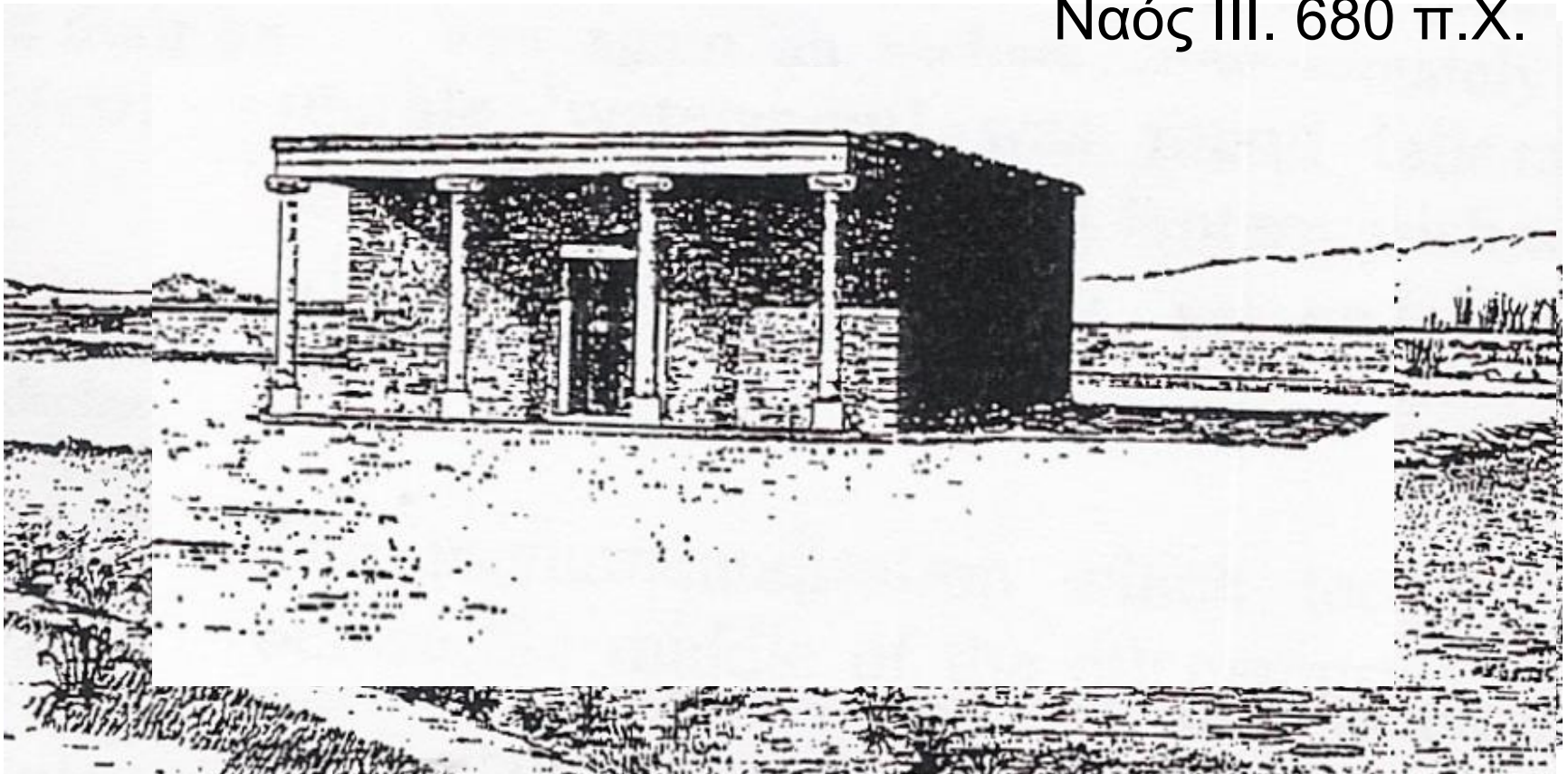

# ΝΑΕΟΣ

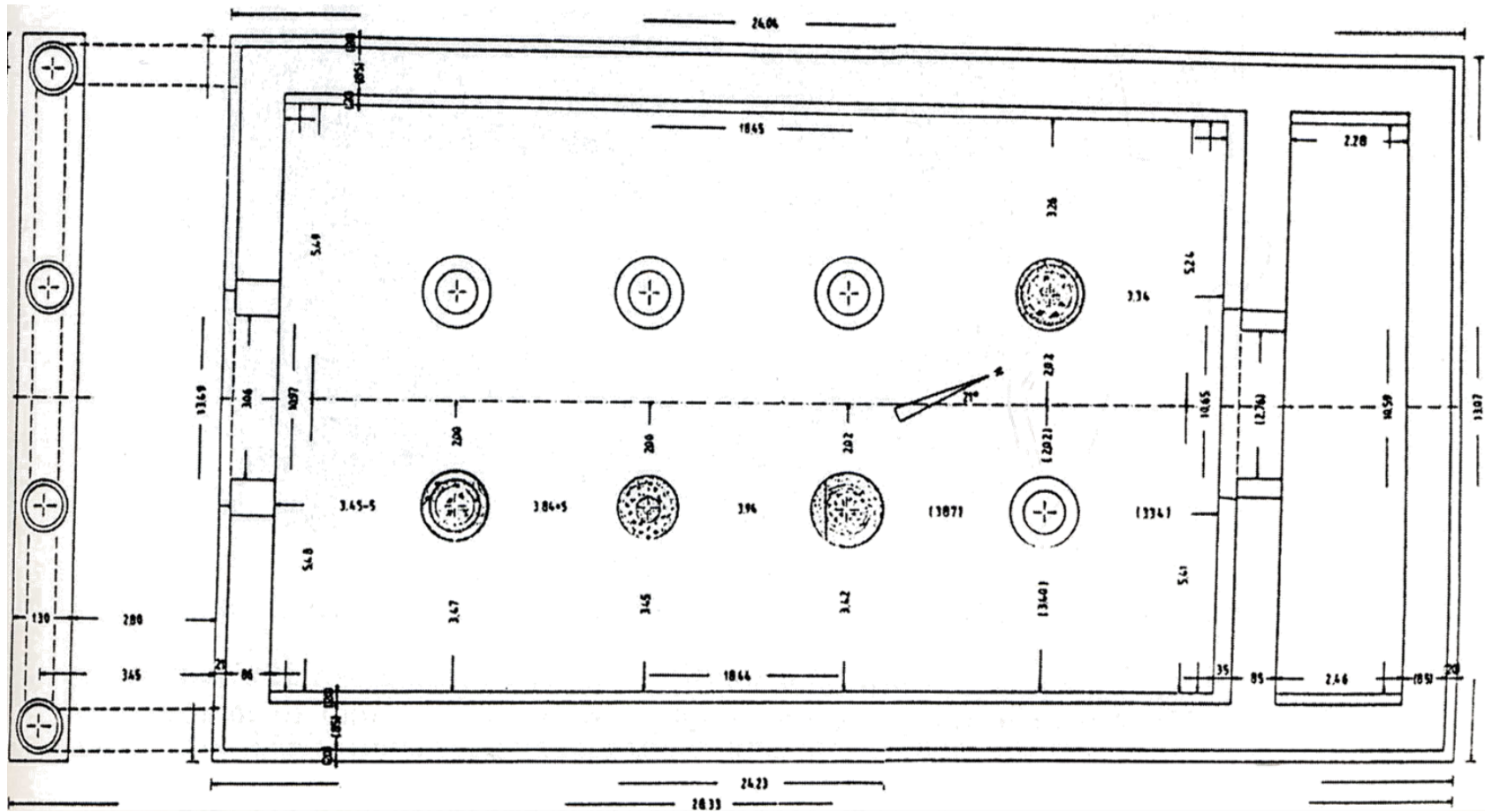

ο μεγάλος αρχαϊκός ναός IV στο Ιερό των Υρίων

(περ. 580-570 π.Χ.)

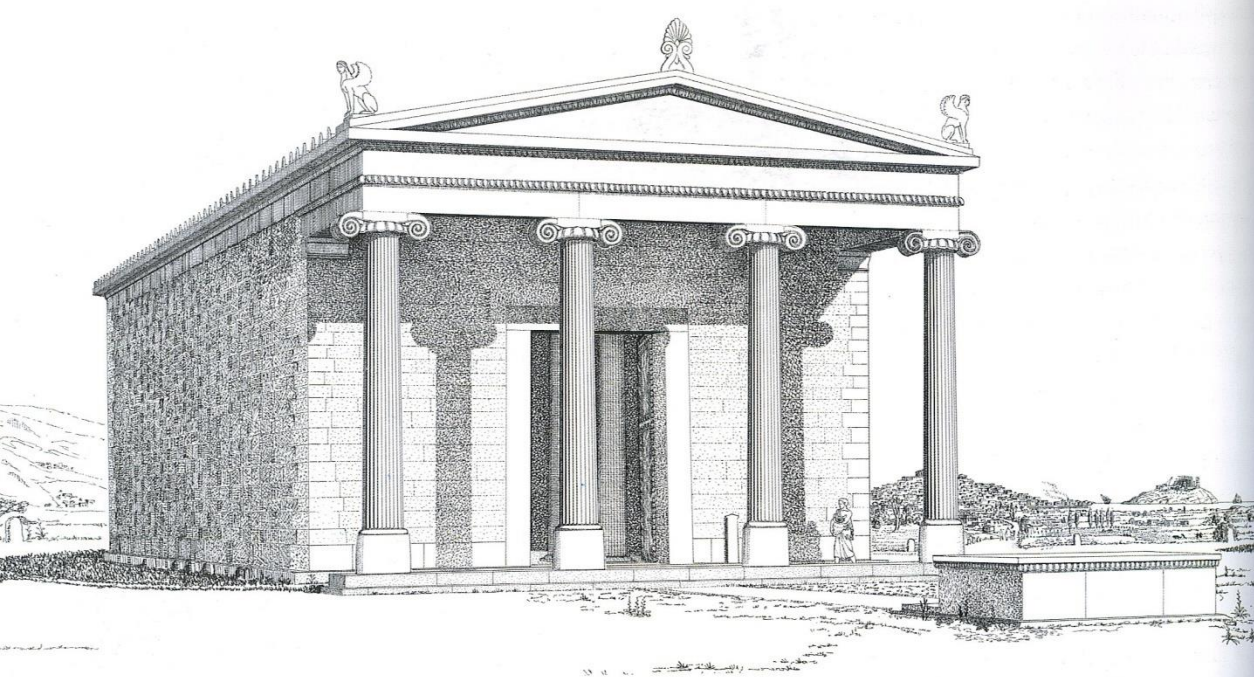

# ΥΡΙΑ, ΝΑΕΟΣ (580- 550)

- ΡΗΧΑ ΘΕΜΕΛΙΑ
- ΓΡΑΝΙΤΕΝΙΟΙ ΤΟΙΧΟΙ
- ΜΑΡΜΑΡΙΝΟΙ ΚΙΟΝΕΣ
- ΜΑΡΜΑΡΙΝΑ ΘΥΡΩΜΑΤΑ
- ΜΑΡΜΑΡΙΝΗ ΚΕΡΑΜΩΣΗ
- ΠΟΙΚΙΛΙΑ ΚΙΟΝΟΚΡΑΝΩΝ
- ΡΑΒΔΩΣΕΙΣ ΑΠΟ 24 ΕΩΣ 36
- ΑΔΥΤΟ ΓΙΑ ΚΟΛΟΣΣΙΚΟ
- ΑΓΑΛΜΑ



Φωτογραφία του χώρου

# ΚΙΟΝΟΚΡΑΝΟ ΑΠΟ ΤΑ ΥΡΙΑ ΤΗΣ ΝΑΞΟΥ

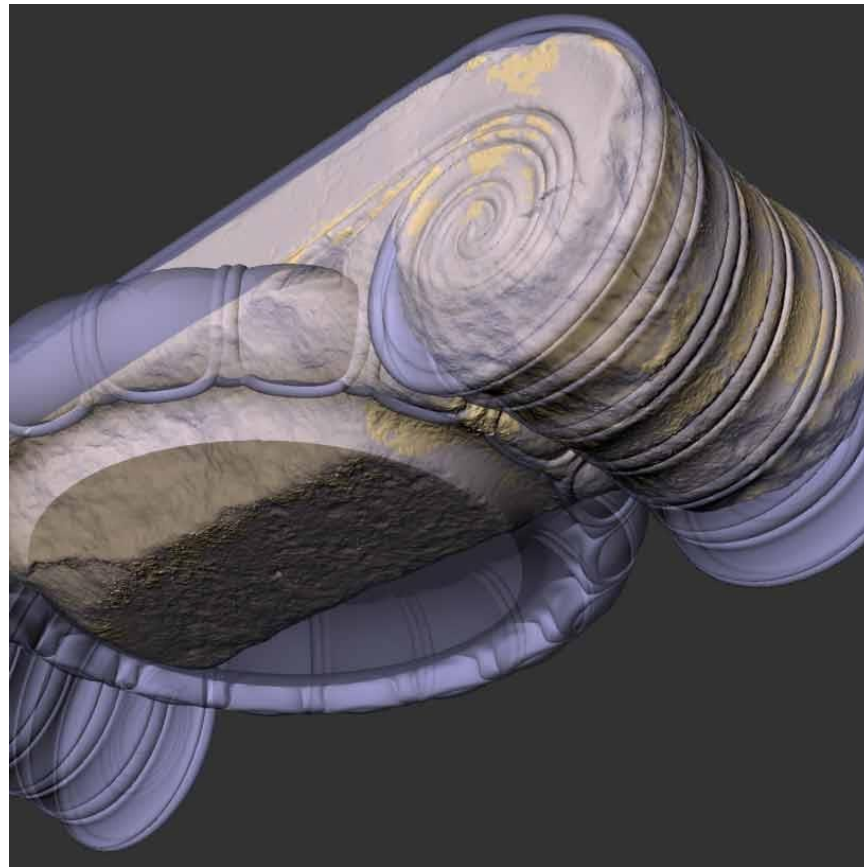





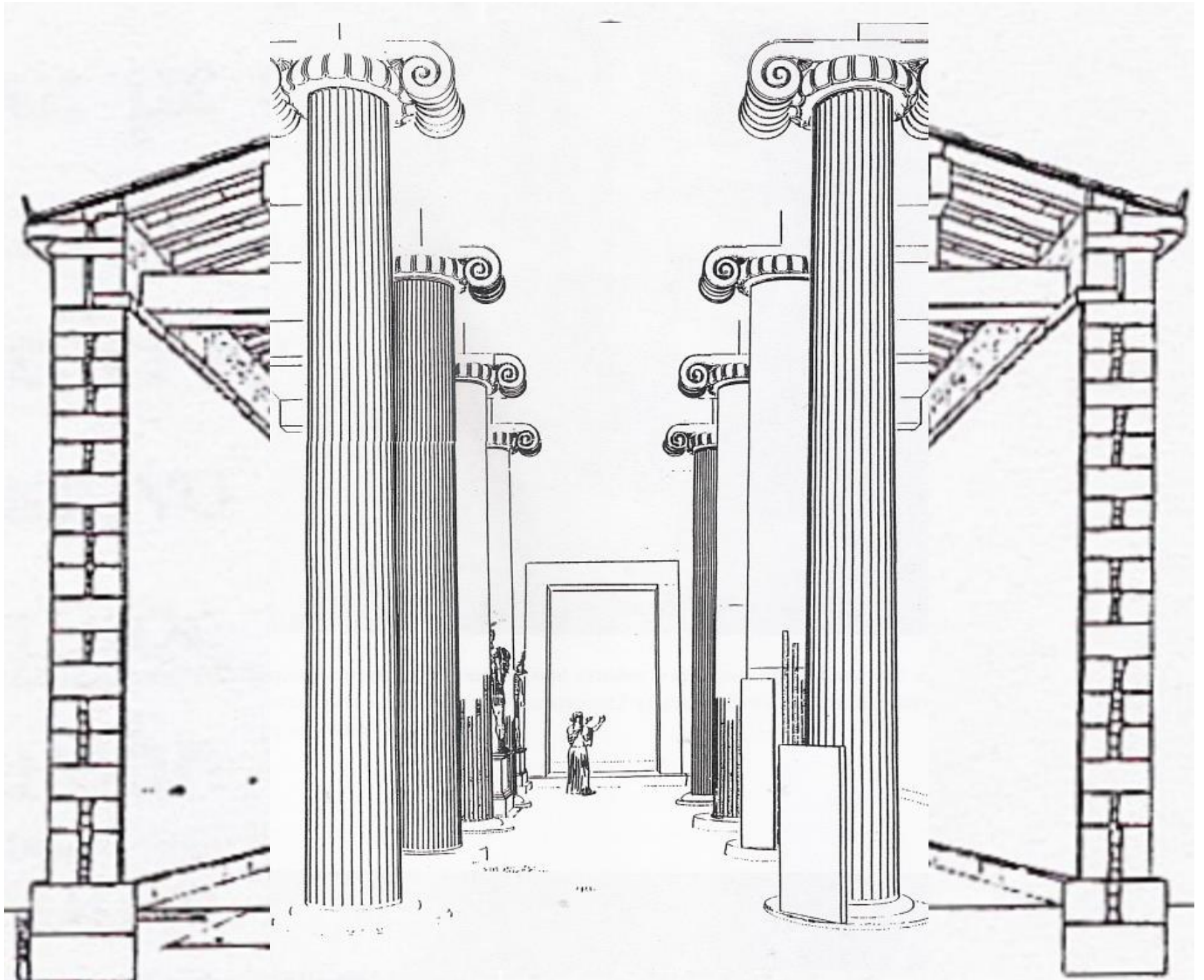



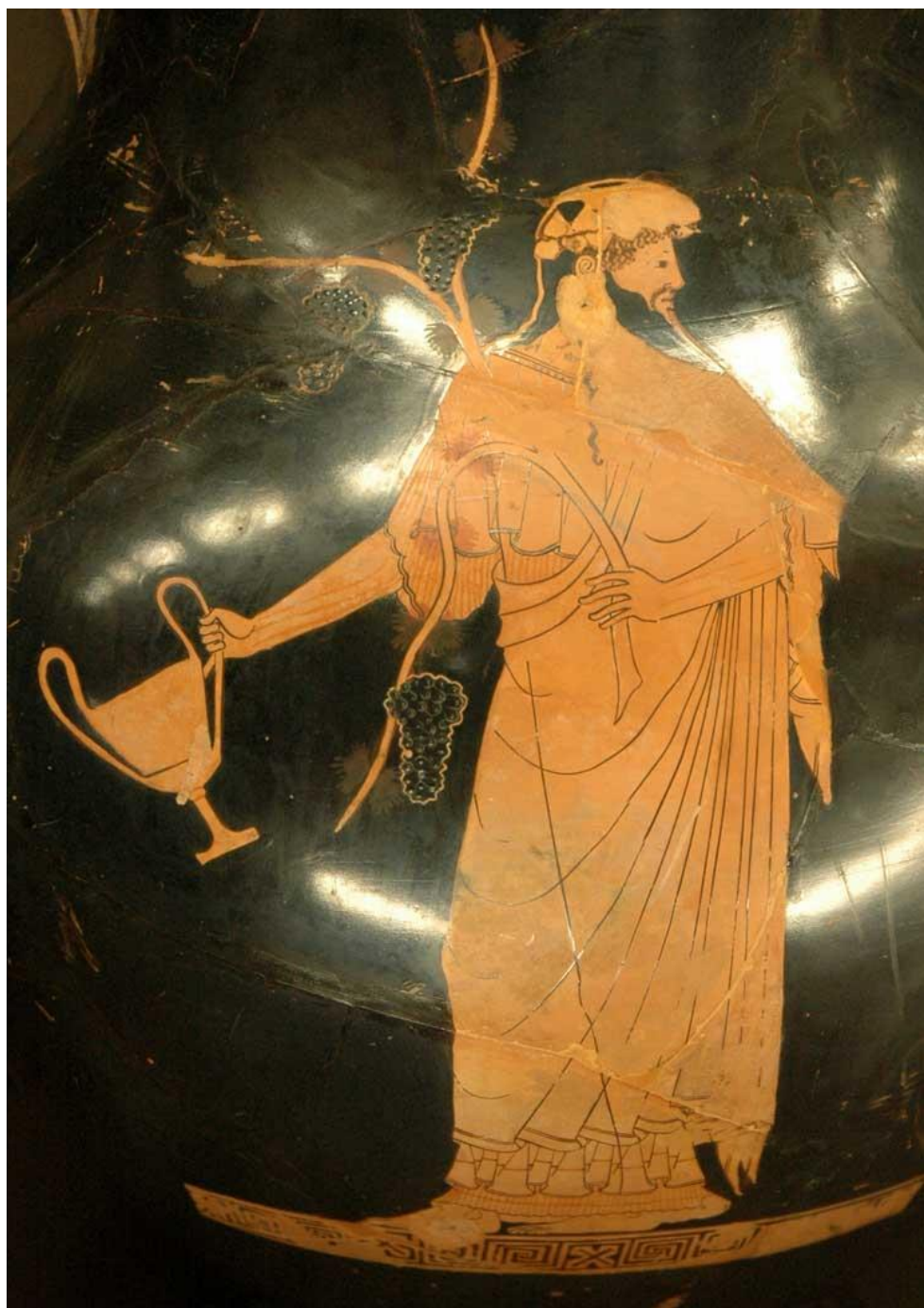

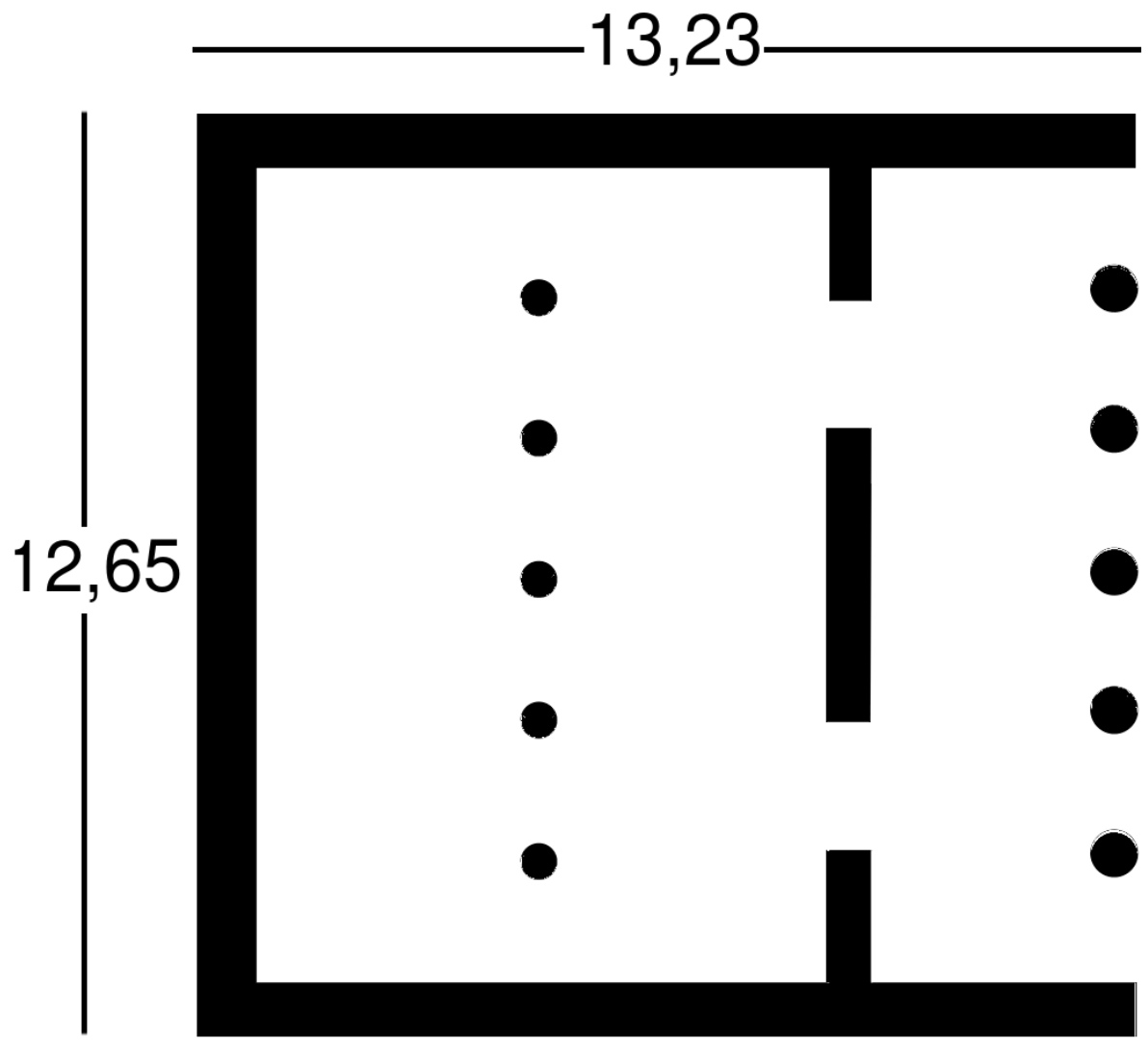

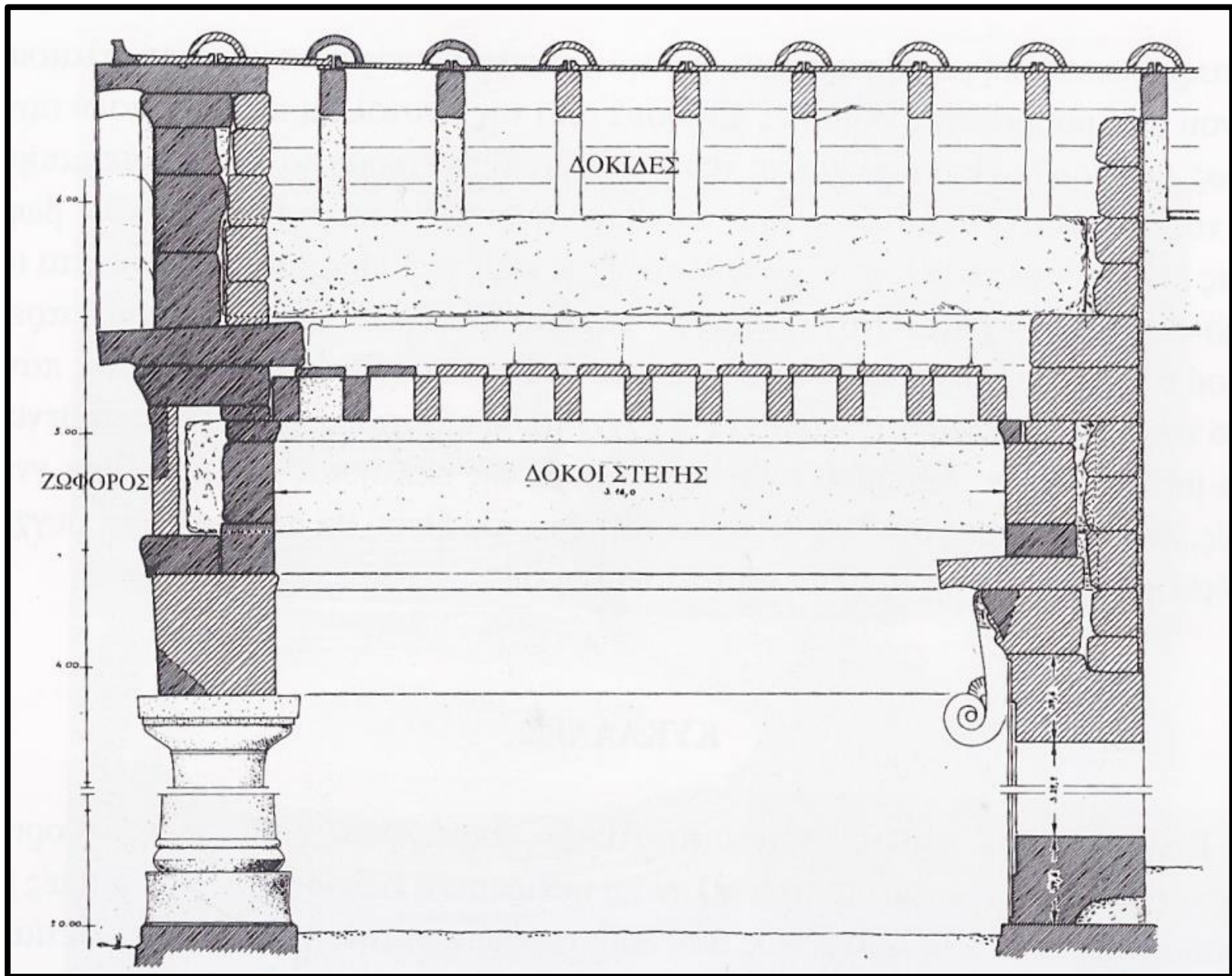

# Η ΟΛΟΜΑΡΜΑΡΗ ΣΤΕΓΗ ΚΑΙ ΚΕΡΑΜΩΣΗ ΤΟΥ ΝΑΟΥ ΣΤΟ ΣΑΓΚΡΙ ΤΗΣ ΝΑΞΟΥ

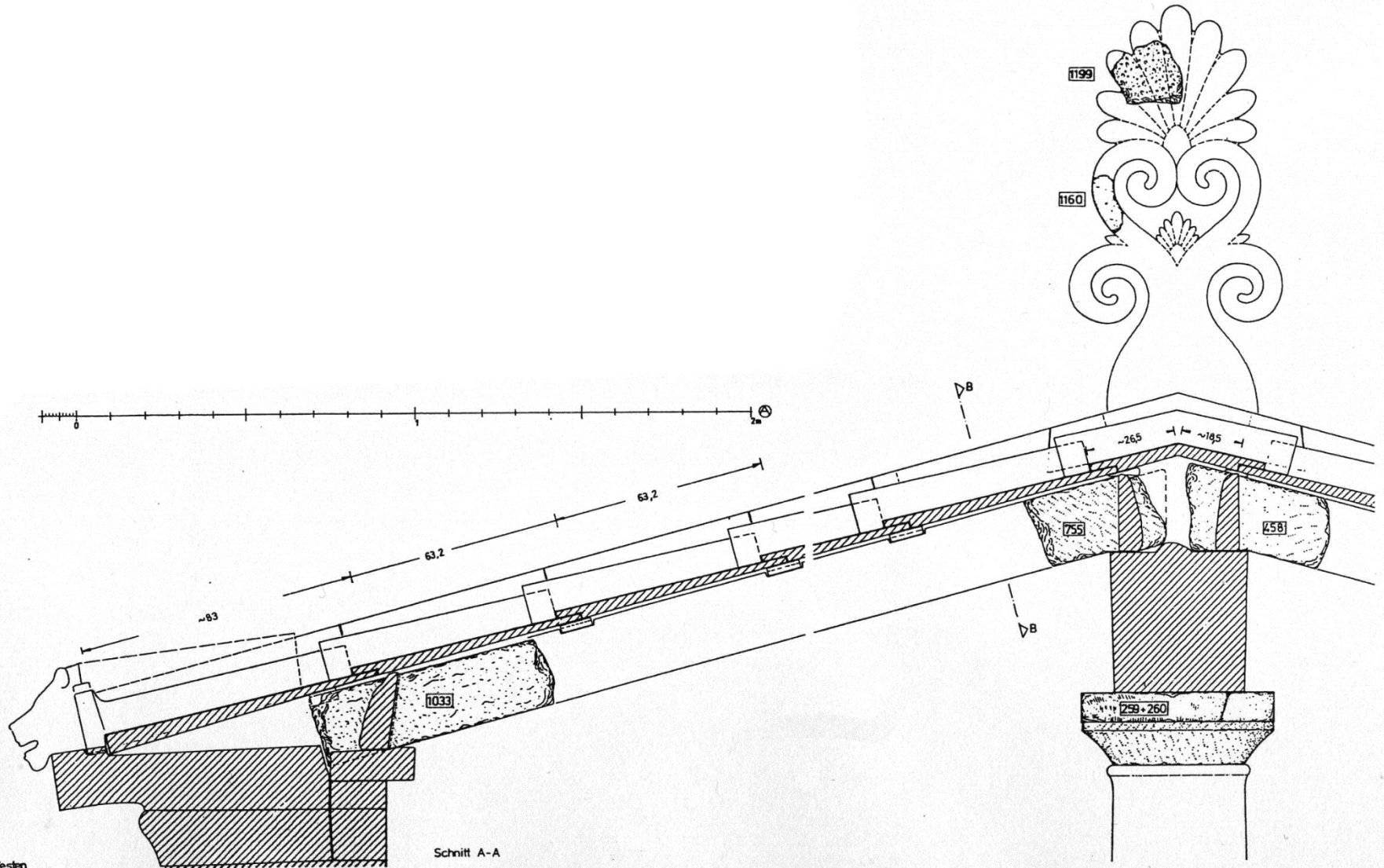

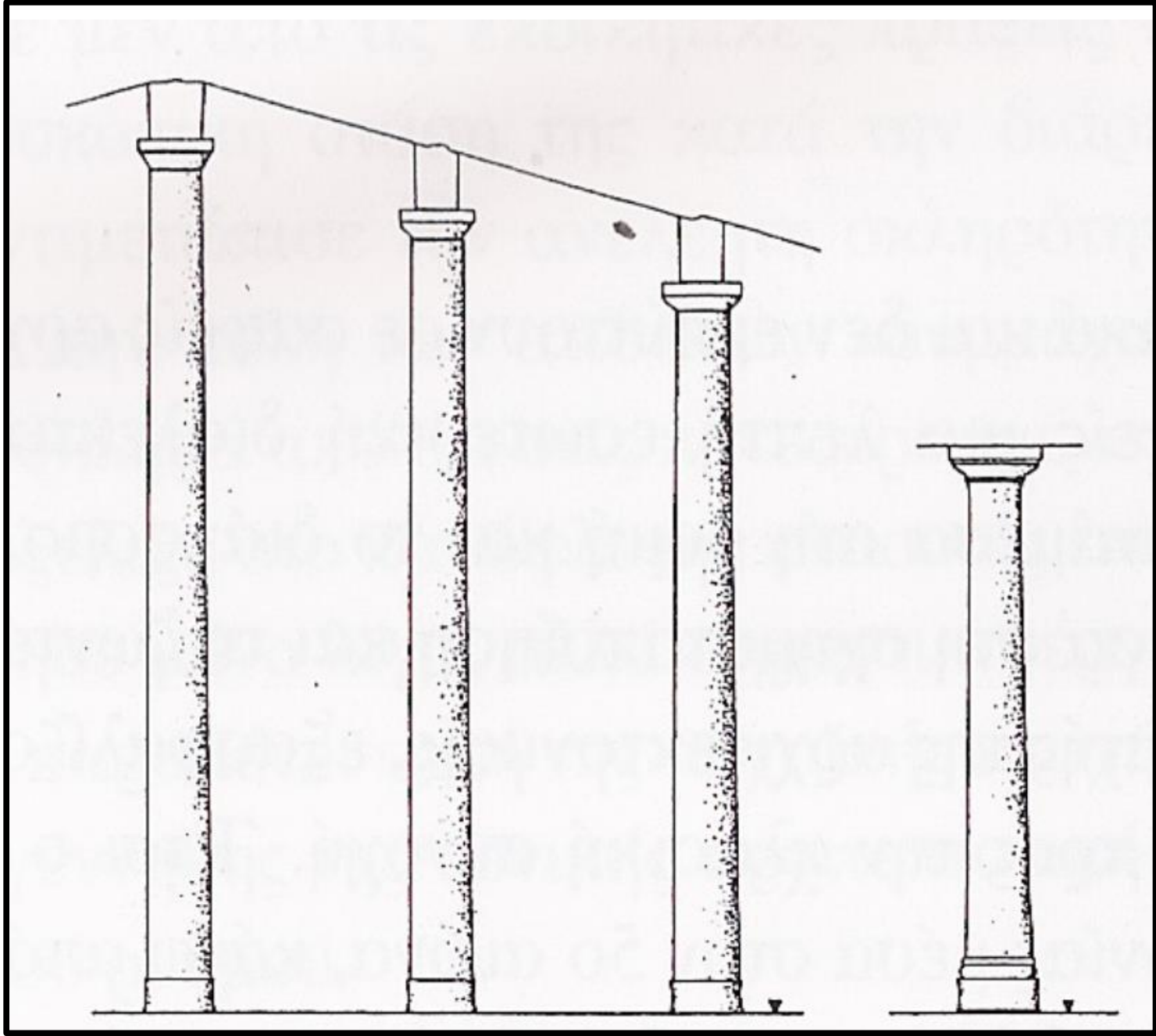

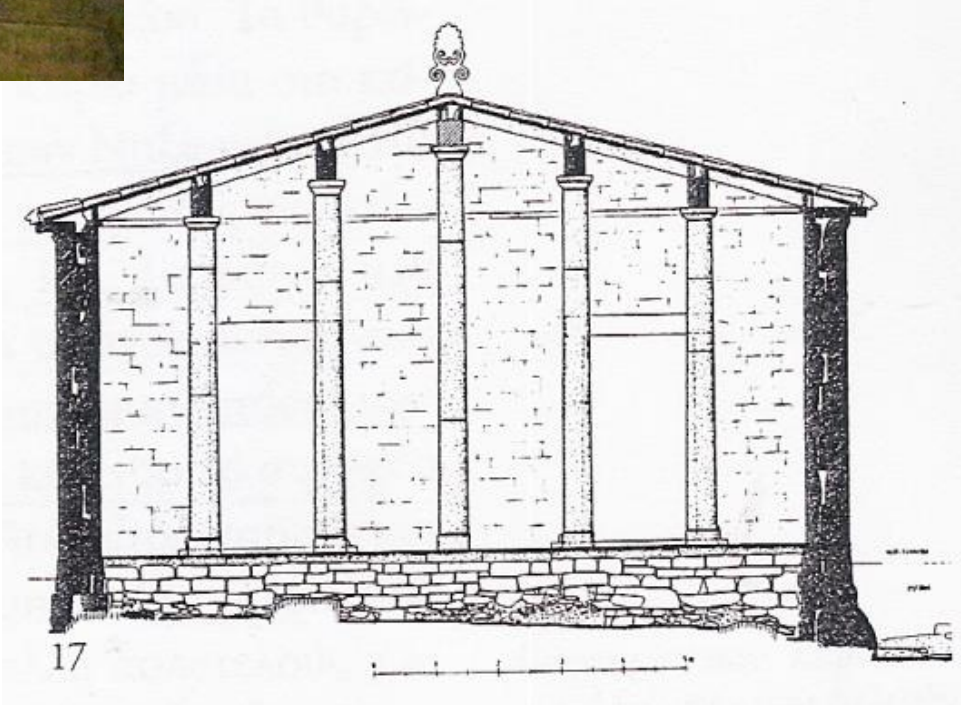
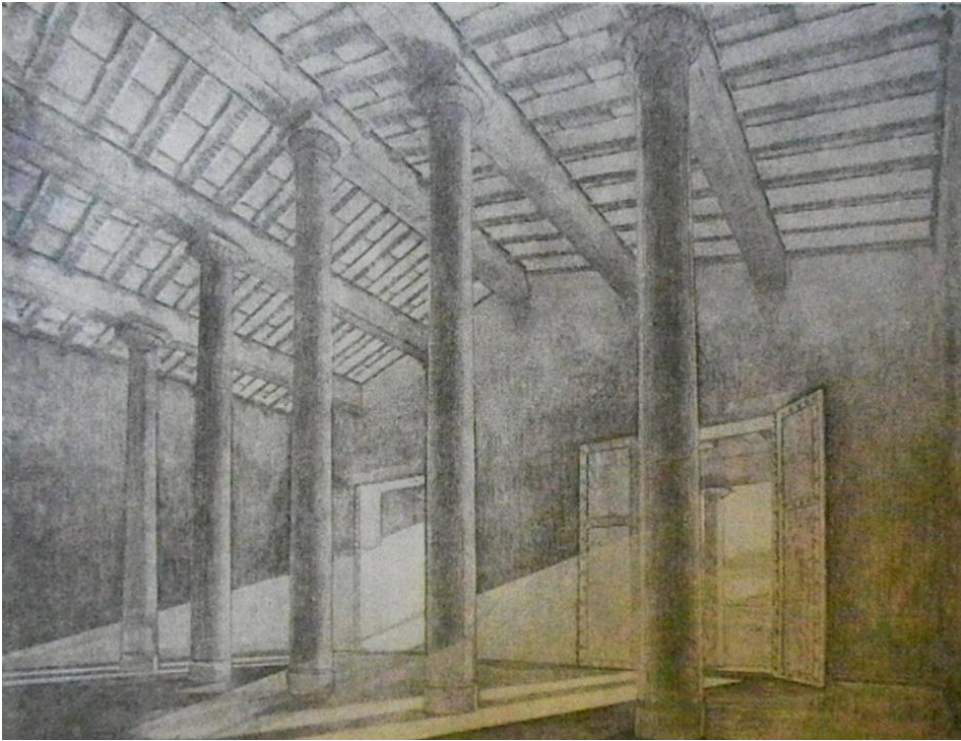



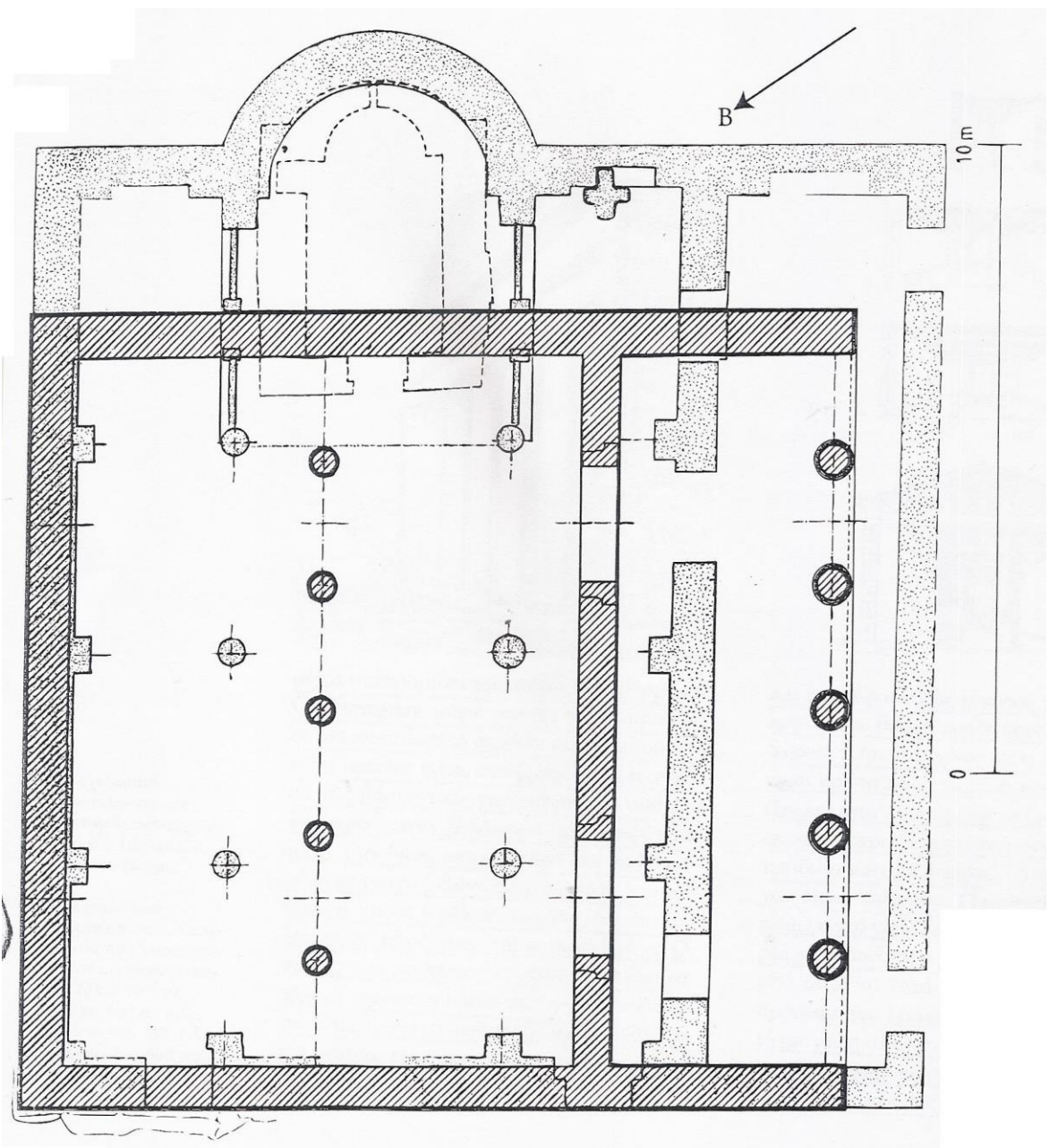

# Ο ΝΑΟΣ ΤΗΣ ΔΗΜΗΤΡΑΣ ΣΤΟ ΣΑΓΚΡΙ ΤΗΣ ΝΑΞΟΥ (540-530 π.Χ.)

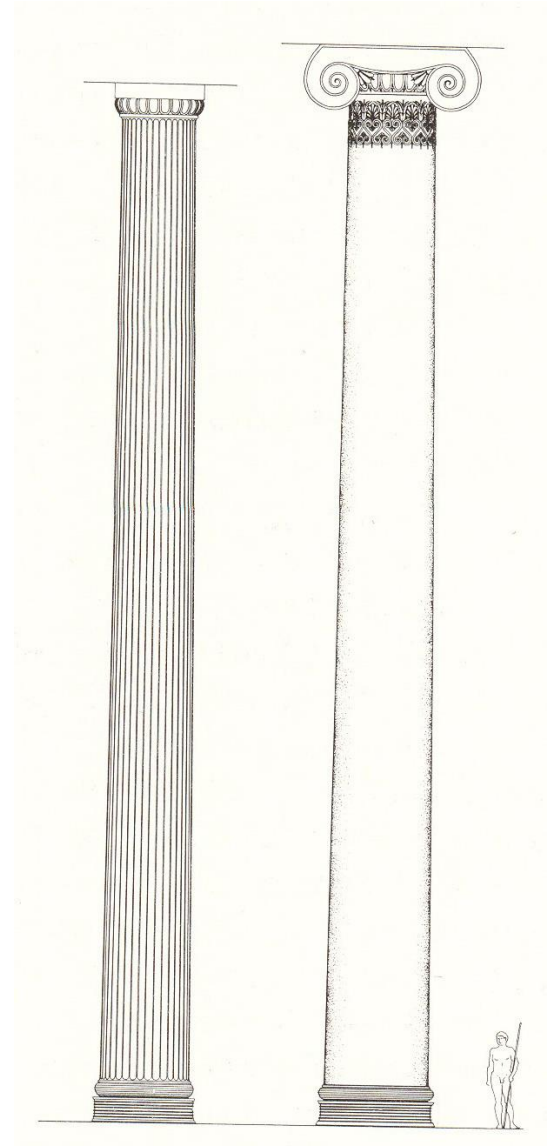





# ΝΑΟΣ ΤΟΥ ΑΠΟΛΛΩΝΑ ΔΗΛΙΟΥ ΣΤΗ ΝΑΞΟ (530)

\* «ΔΗΛΙΑ» \* ΤΥΡΑΝΝΟΣ ΛΥΓΔΑΜΙΣ



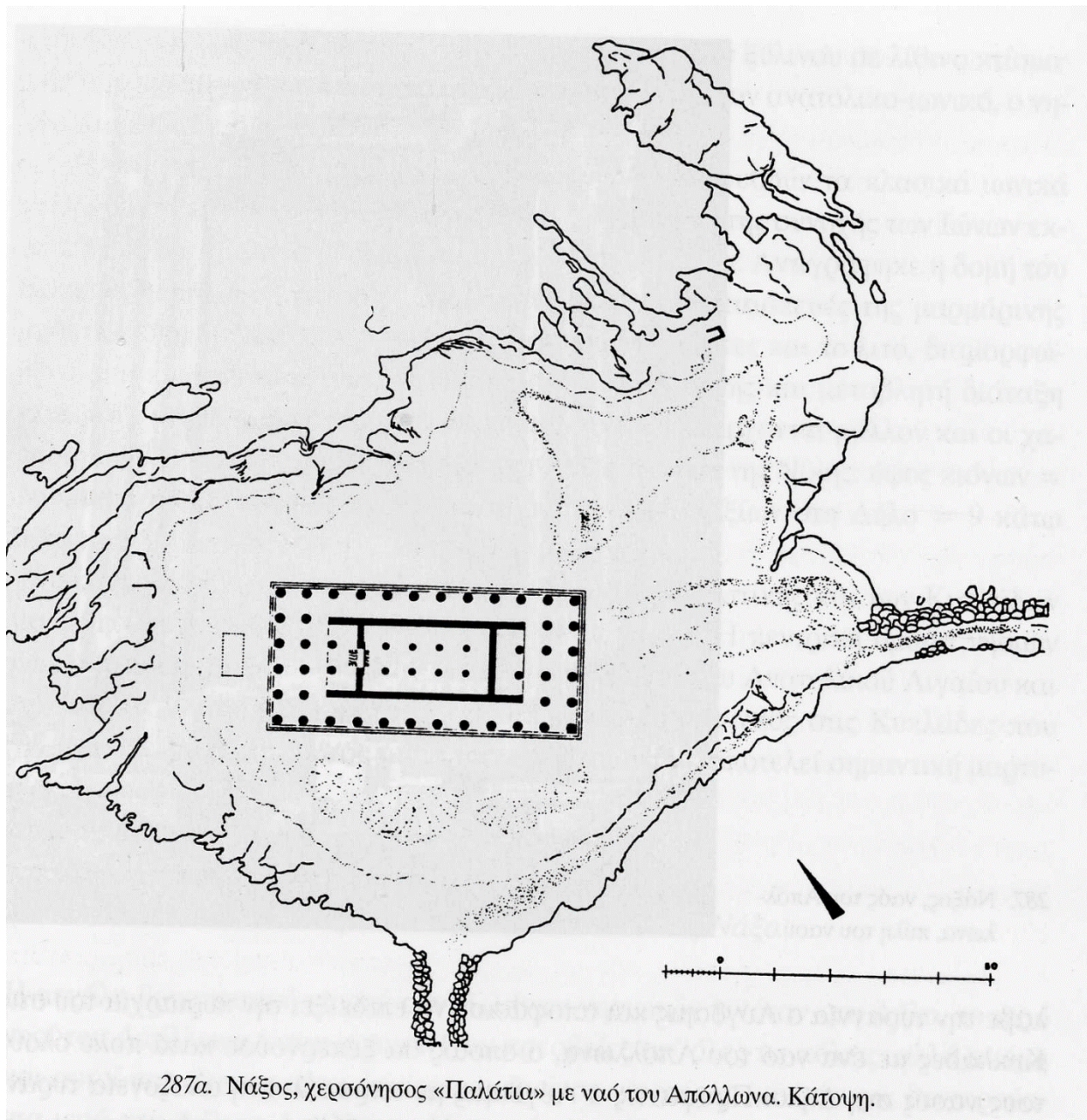

287a. Νάξος, χερσόνησος «Παλάτια» με ναό του Απόλλωνα. Κάτοψη.



- ΒΑΘΕΙΑ ΘΕΜΕΛΙΩΣΗ ΑΠΟ ΜΑΡΜΑΡΟ
- ΠΕΡΙΠΤΕΡΟΣ
- ΒΑΘΥΤΕΡΟ ΔΑΠΕΔΟ - 1.20 μ.
- ΚΙΟΝΟΚΡΑΝΑ ΠΡΟΝΑΟΥ ΜΕ ΦΥΛΛΑ, ΧΩΡΙΣ ΕΛΙΚΕΣ

ΑΔΡΟΔΟΥΛΕΜΕΝΗ ΕΣΩΤΕΡΙΚΗ  
ΟΨΗ ΤΩΝ ΤΟΙΧΩΝ (ΣΑΓΚΡΙ)  
\* ΕΞΕΛΙΓΜΝΟ ΘΥΡΩΜΑ









