

ARCHITECT  
APXI- TEKTON  
TEKTON

- \* CARPENTER

TEYXΩ

# SAWING



**copper flat-edge  
saw blade with  
dry sand abrasive**

Saw stroke  
length 115 cm

**fine mineral and  
copper tailings**

Slot length  
95 cm

**rose granite  
block**

**rock weights  
attached to either  
end of saw blade  
with ropes (32 kg total)**

**wooden handles for  
2 workmen, one at  
either end of saw**

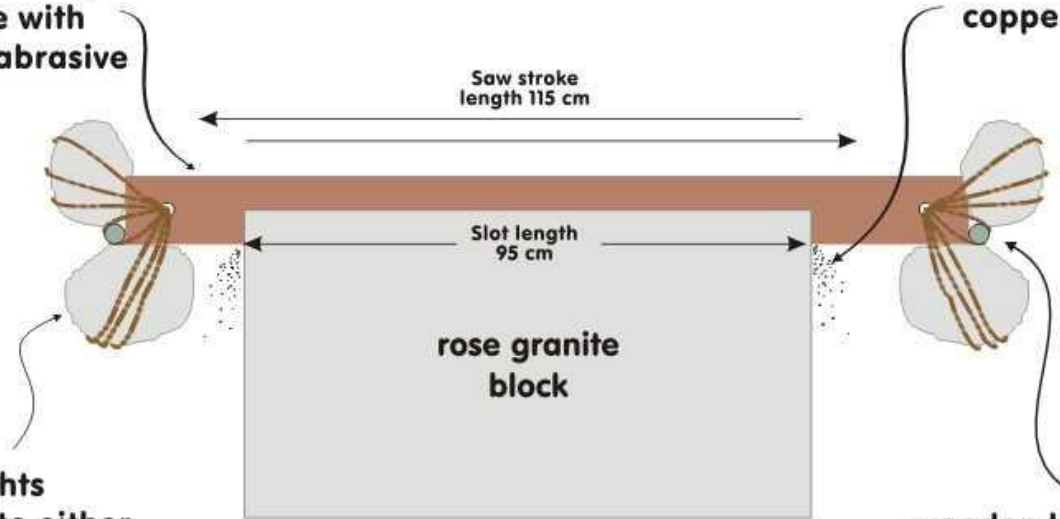



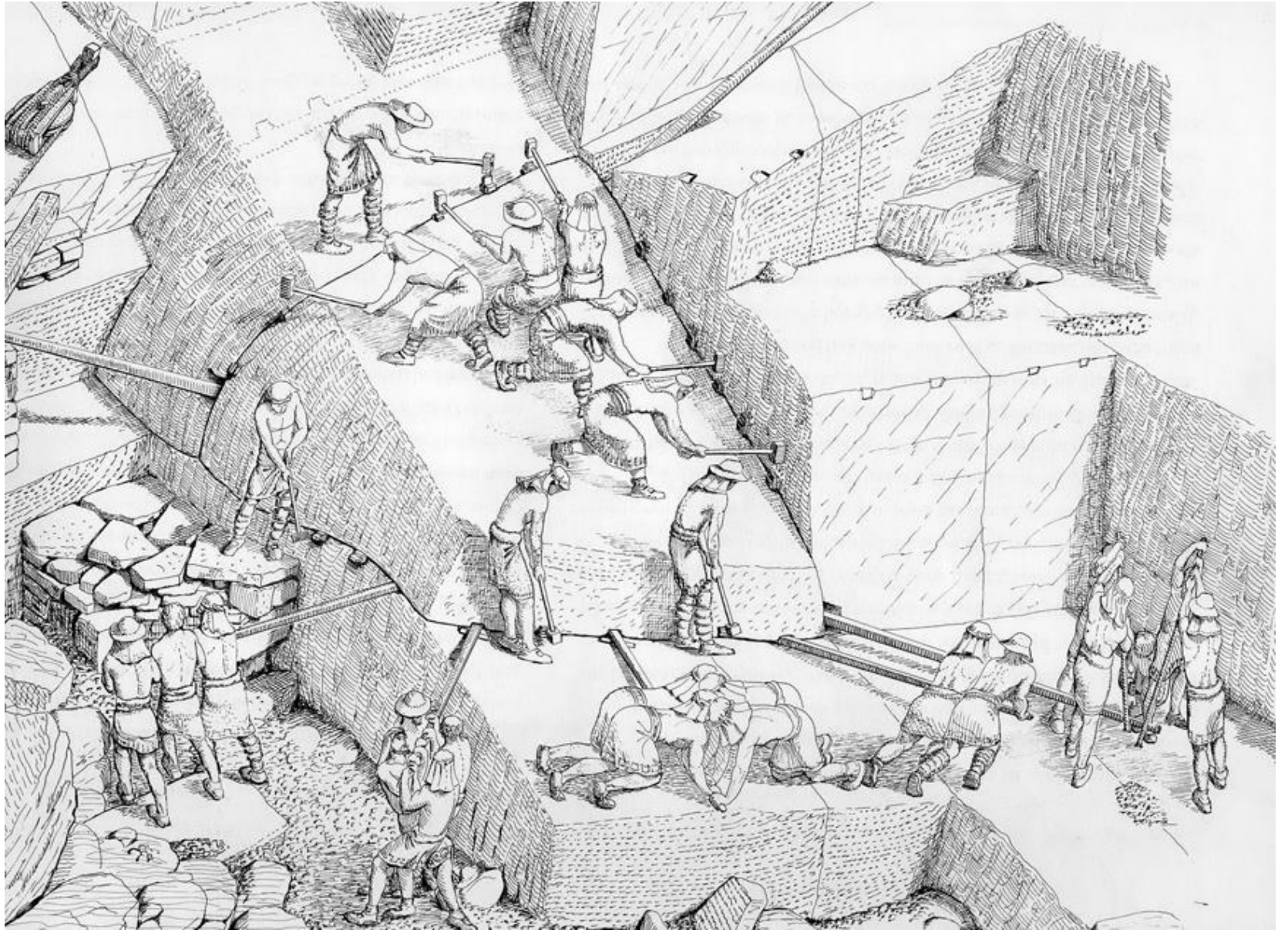

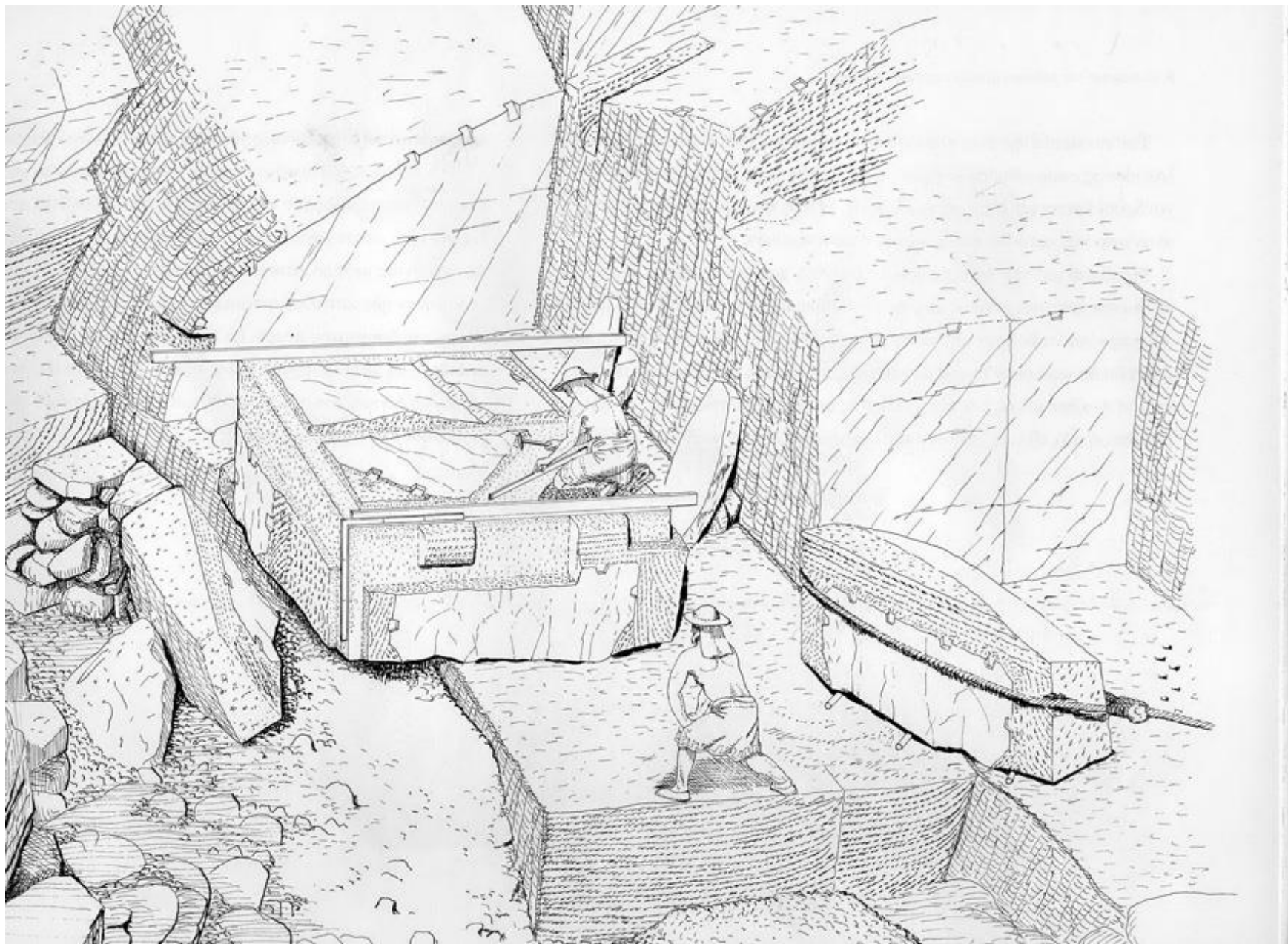

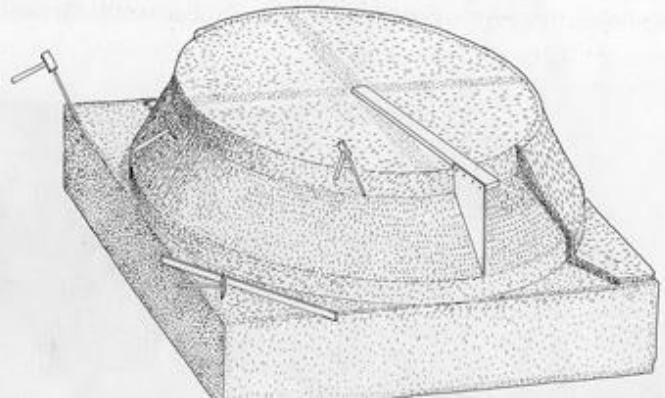
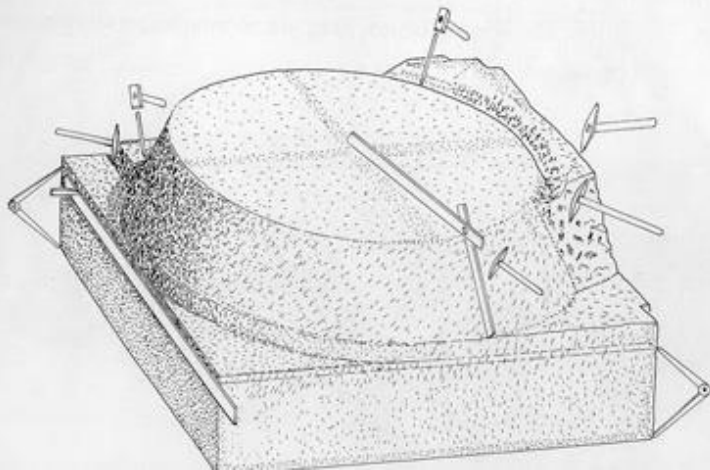
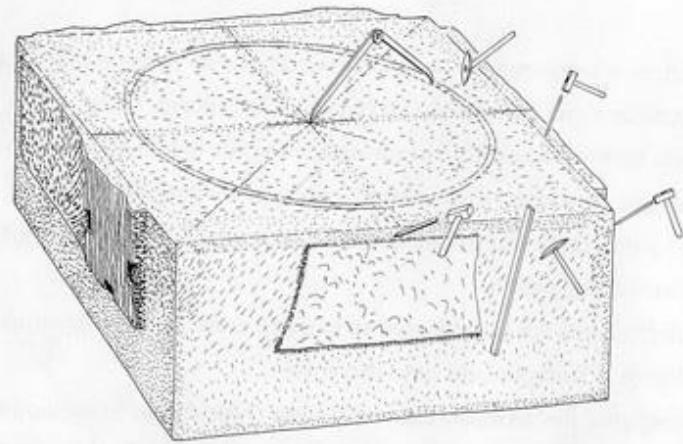
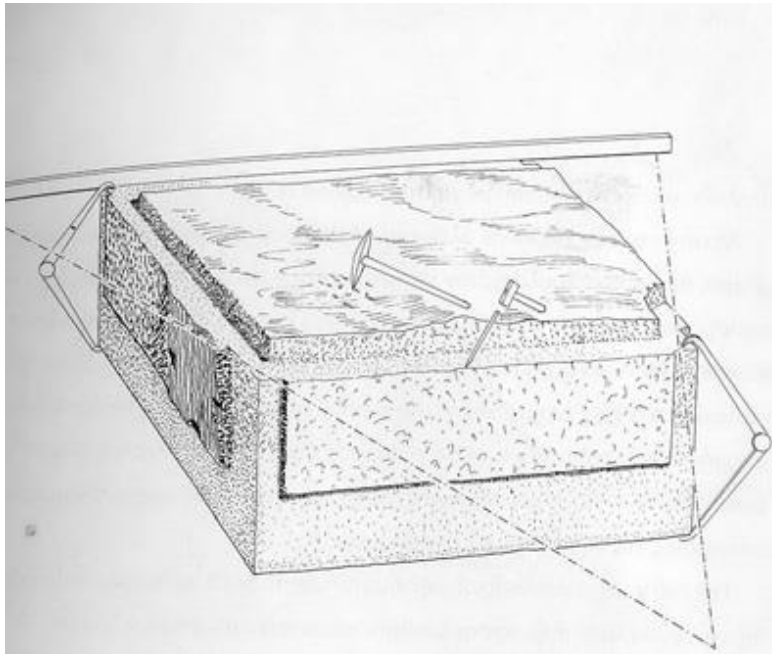

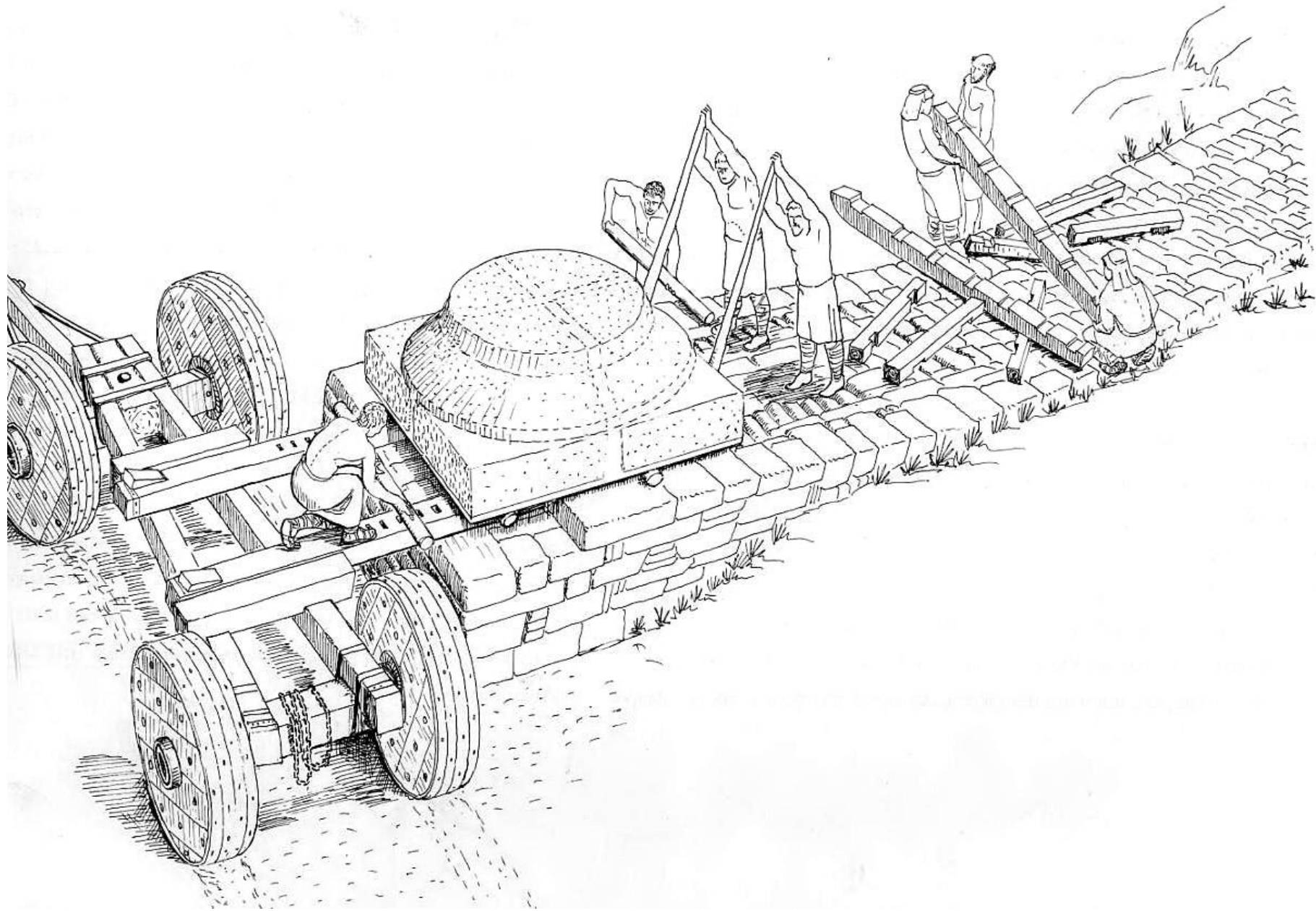



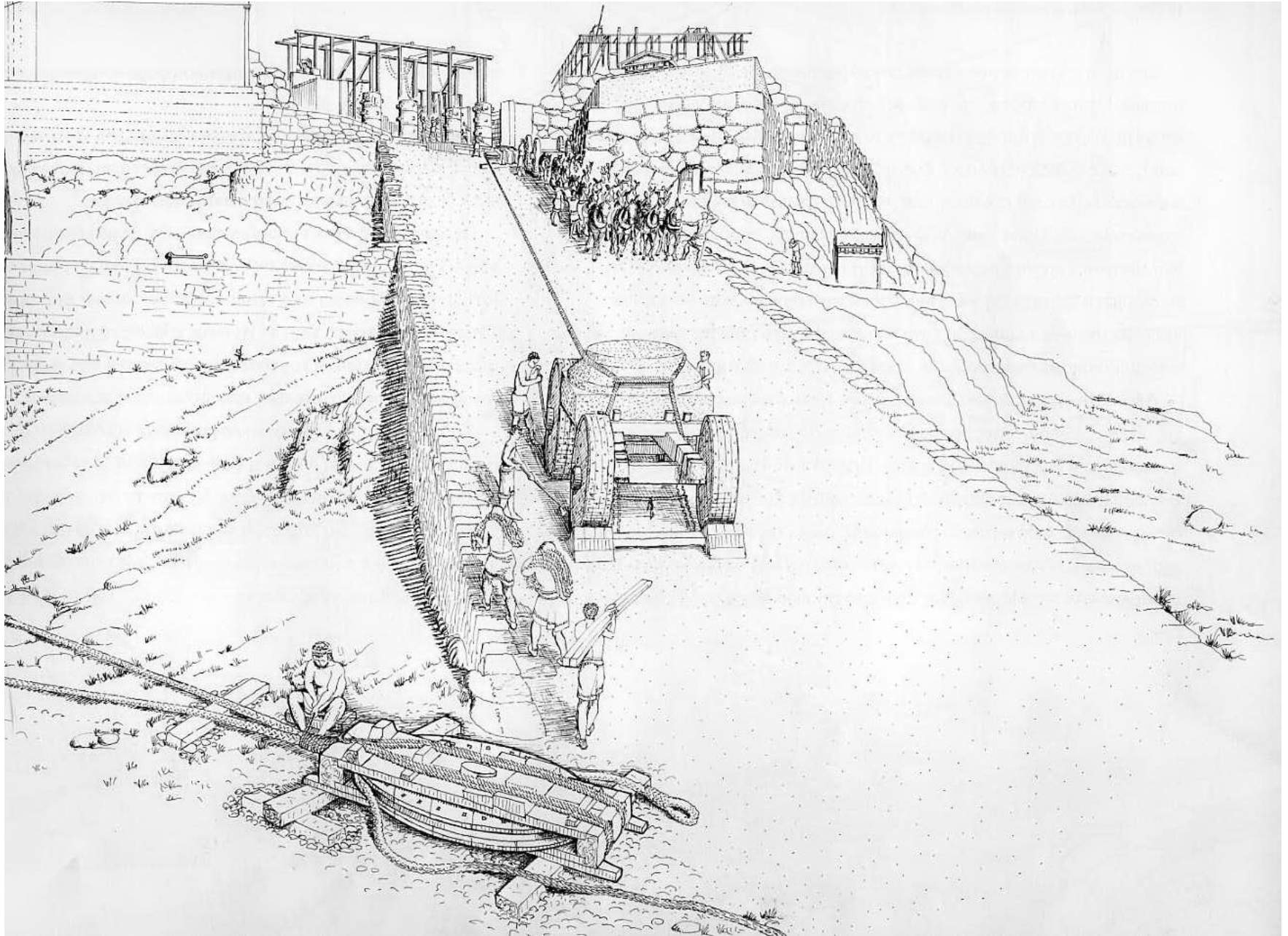







# QUARRIES





www.shutterstock.com · 51433042



www.shutterstock.com · 69293155







# BAALBEK



# ABANDONED COLUMN SHAFTS IN A QUARRY





# DIONYSUS STATUE IN A QUARRY IN NAXOS





## STONEHENGE BUILDER: THE LITHO LIFT

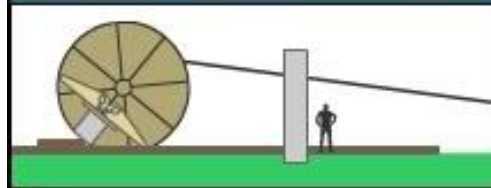

Engineer Nick Weegenaar believes a wooden wheel mechanism similar to his 'Litho Lift' may have been used.

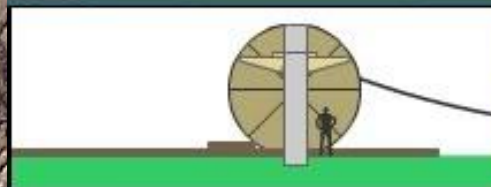
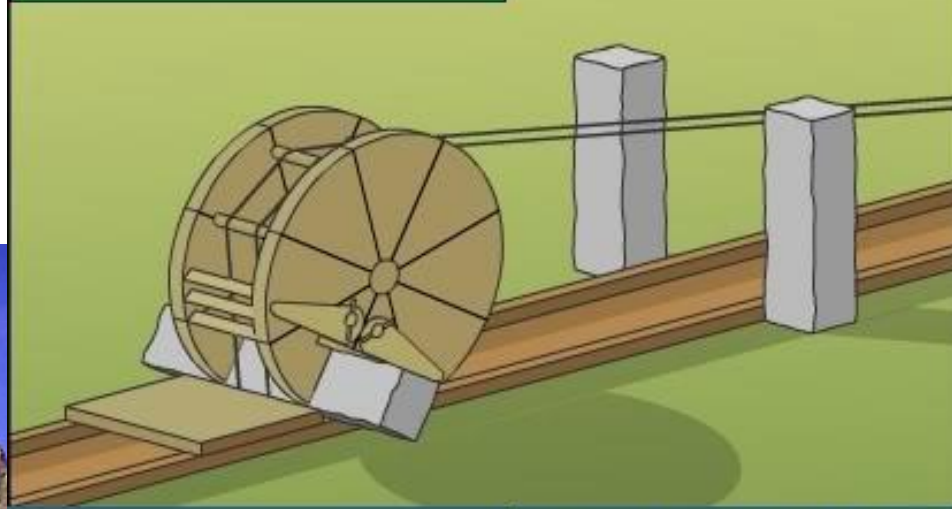

The lintel rolls in the wheel until it is above the uprights, before being lowered down. A track guides the wheel and counterweights act as ballast.

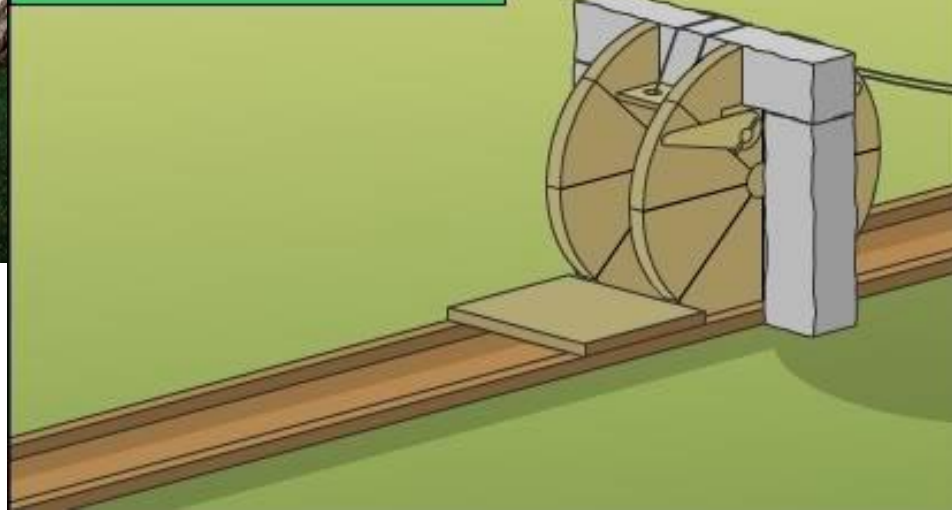









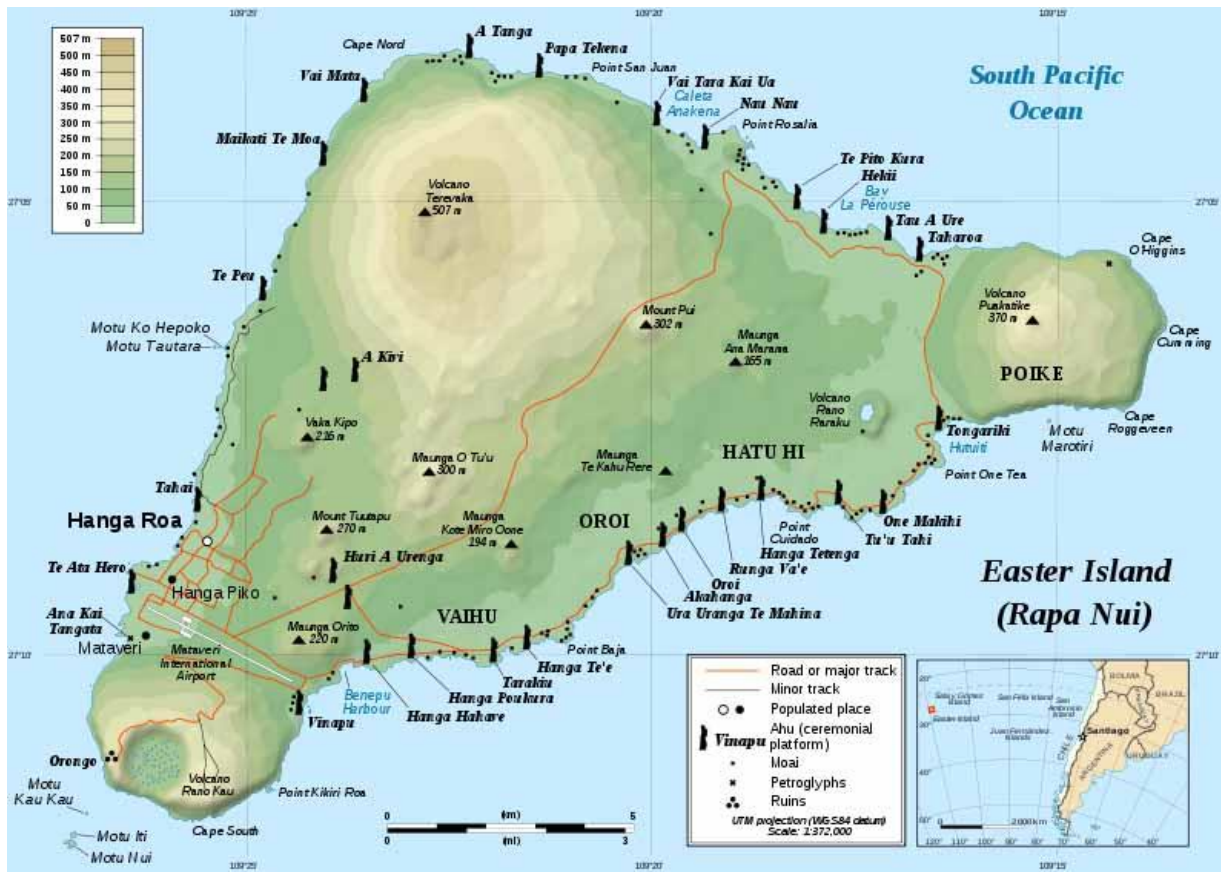



# «LAW FAITH IN HUMANS»

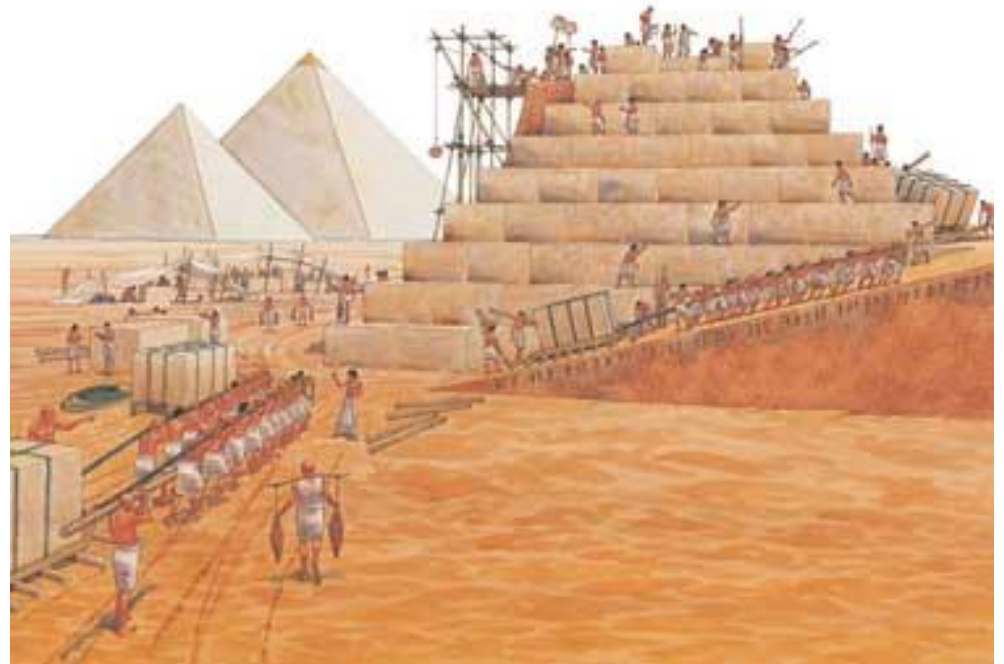
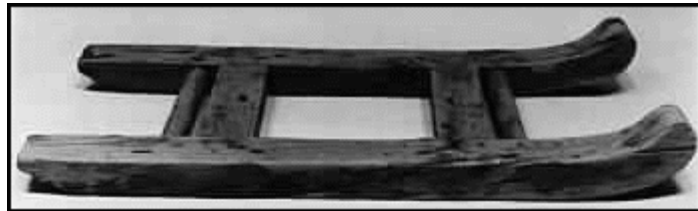

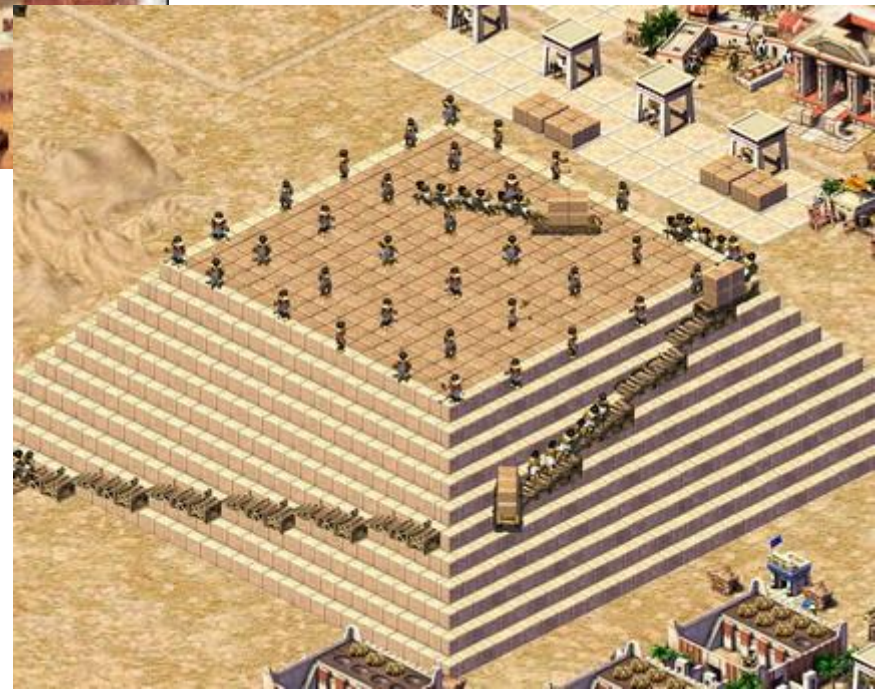



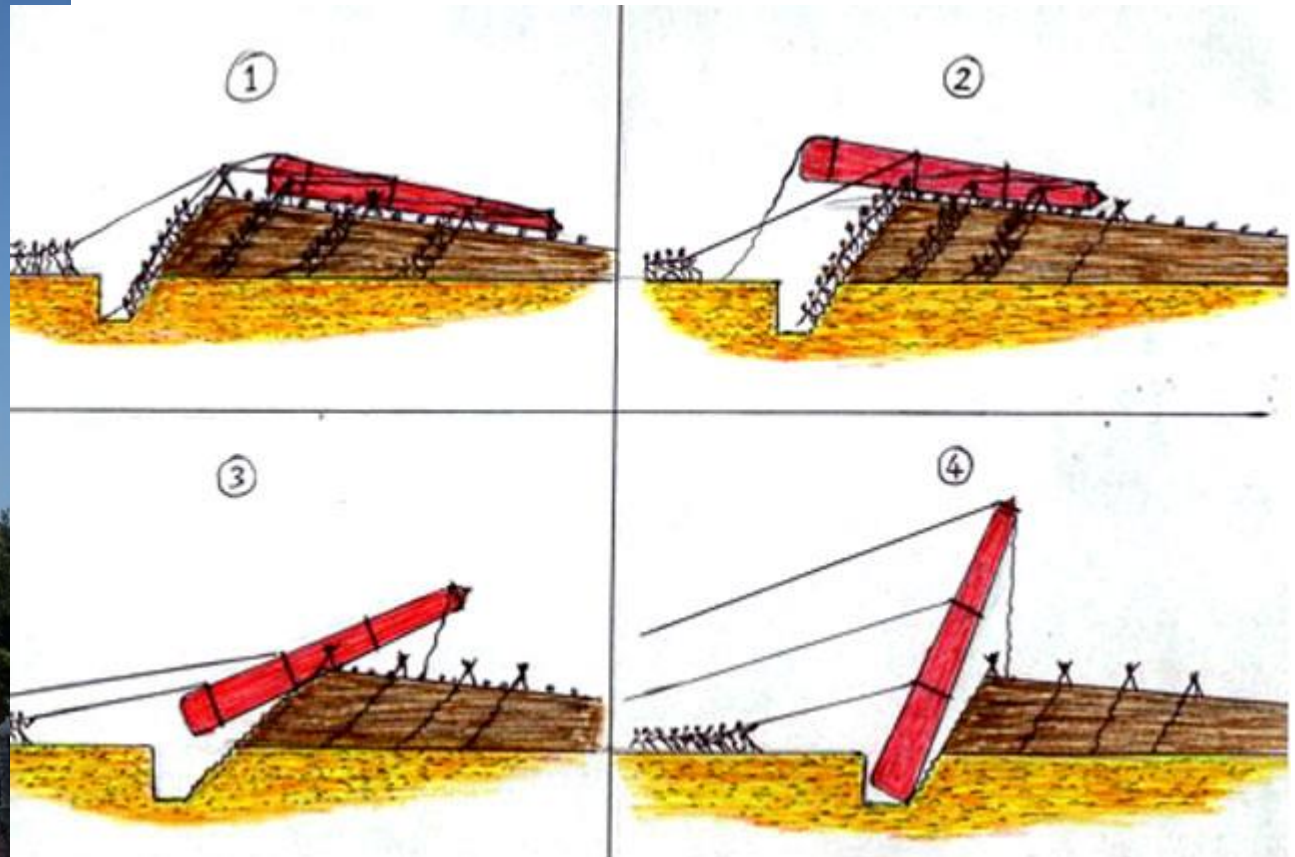

a platform.

Great

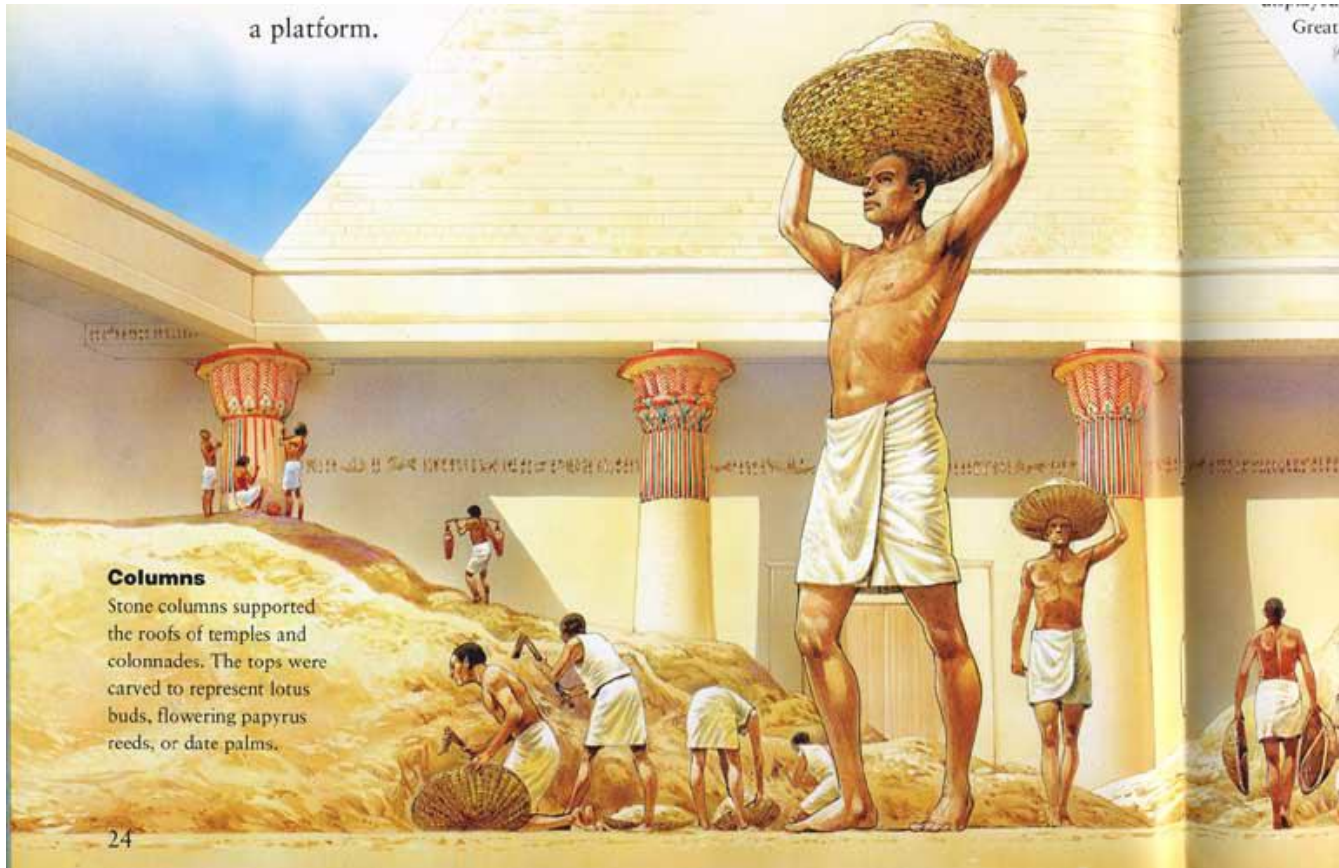

**Columns**

Stone columns supported the roofs of temples and colonnades. The tops were carved to represent lotus buds, flowering papyrus reeds, or date palms.





# CRANES

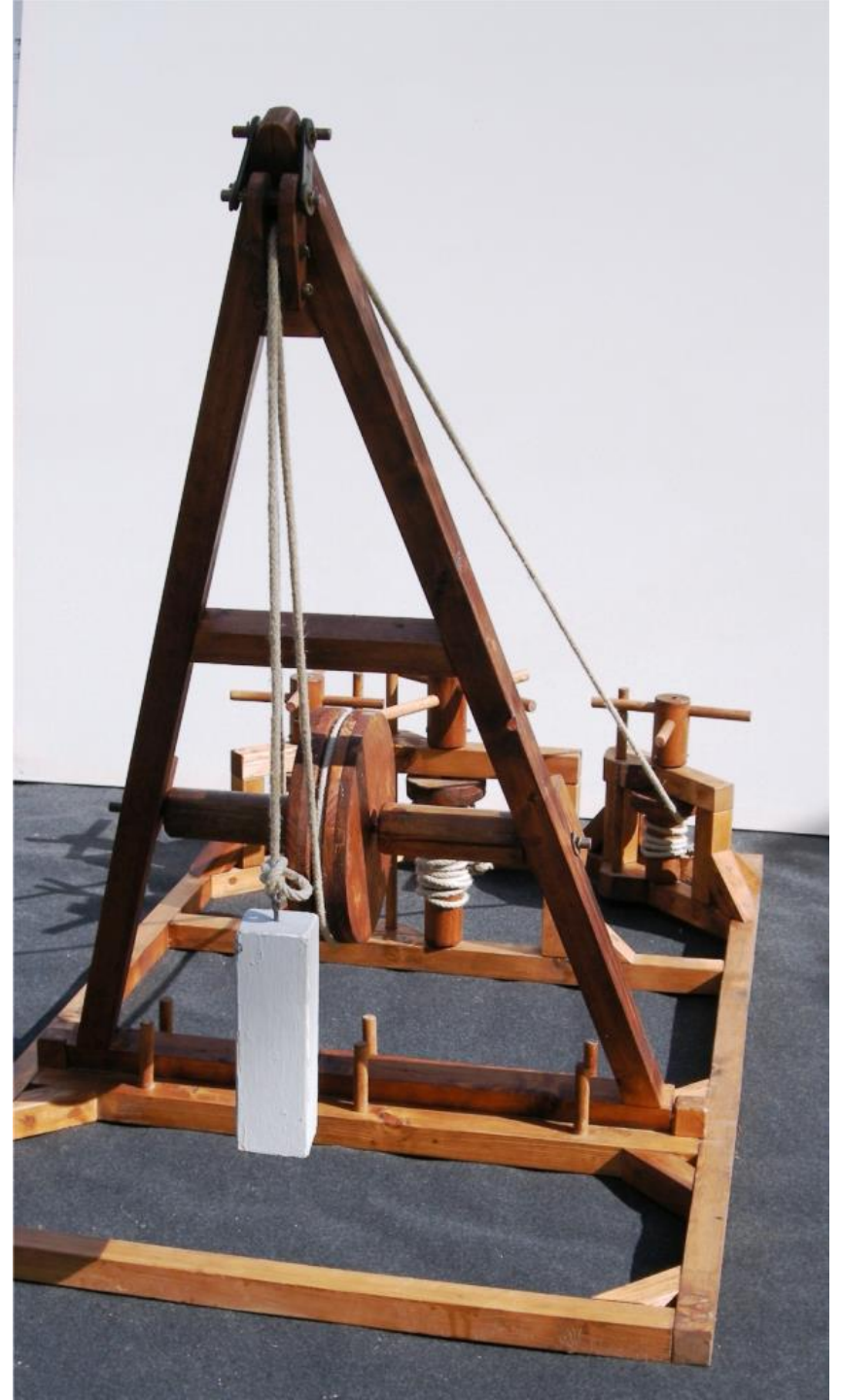



DAE-99016936 - © - DEA / G DAGLI ORTI



www.strenas.com



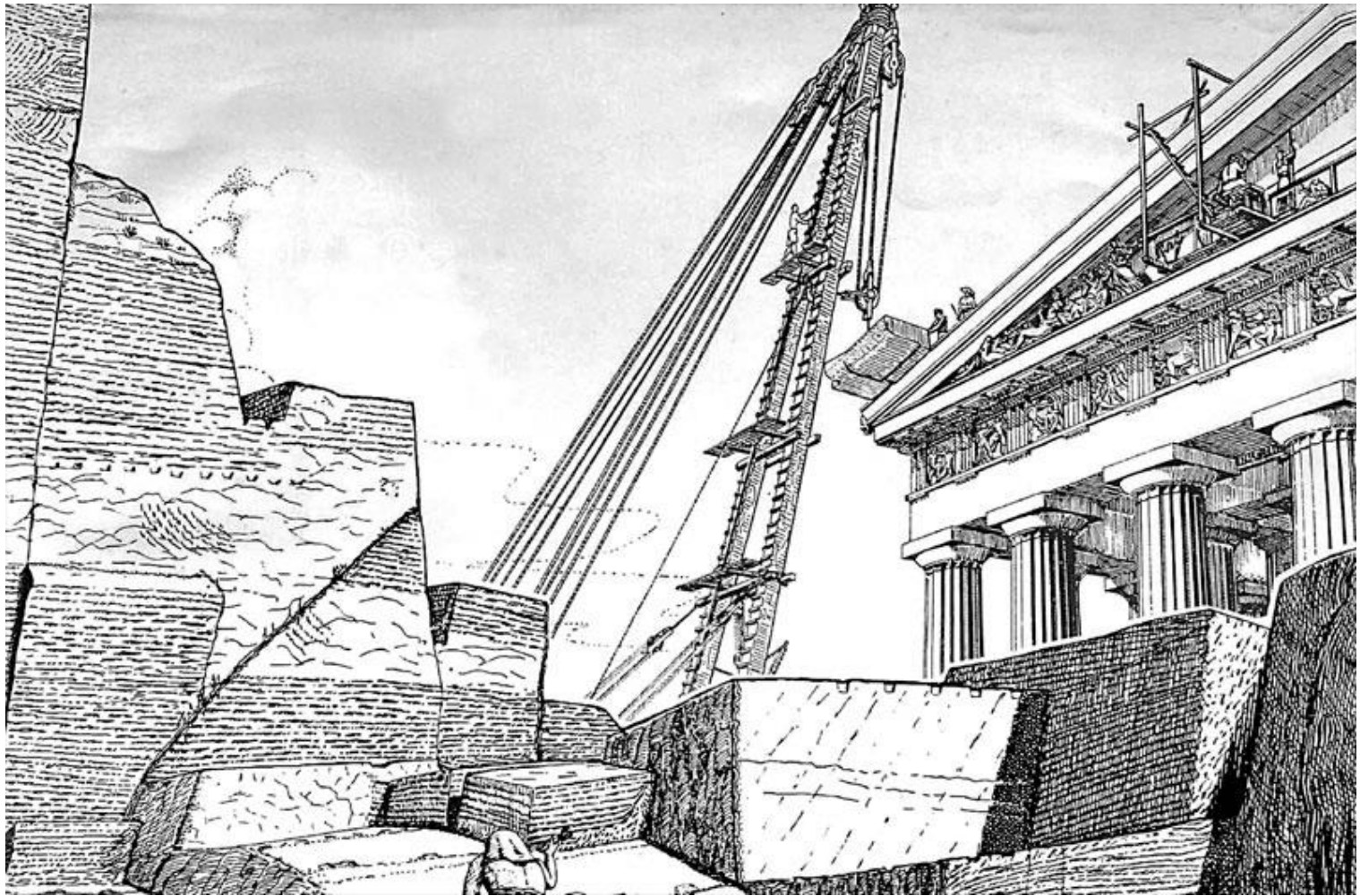

Επιφώση των μαρμάρινων όγκων, από  
βιβλίο Μ. Κορρέ "Απο την Πεντέλη  
στον Παρθενώνα", 1993©

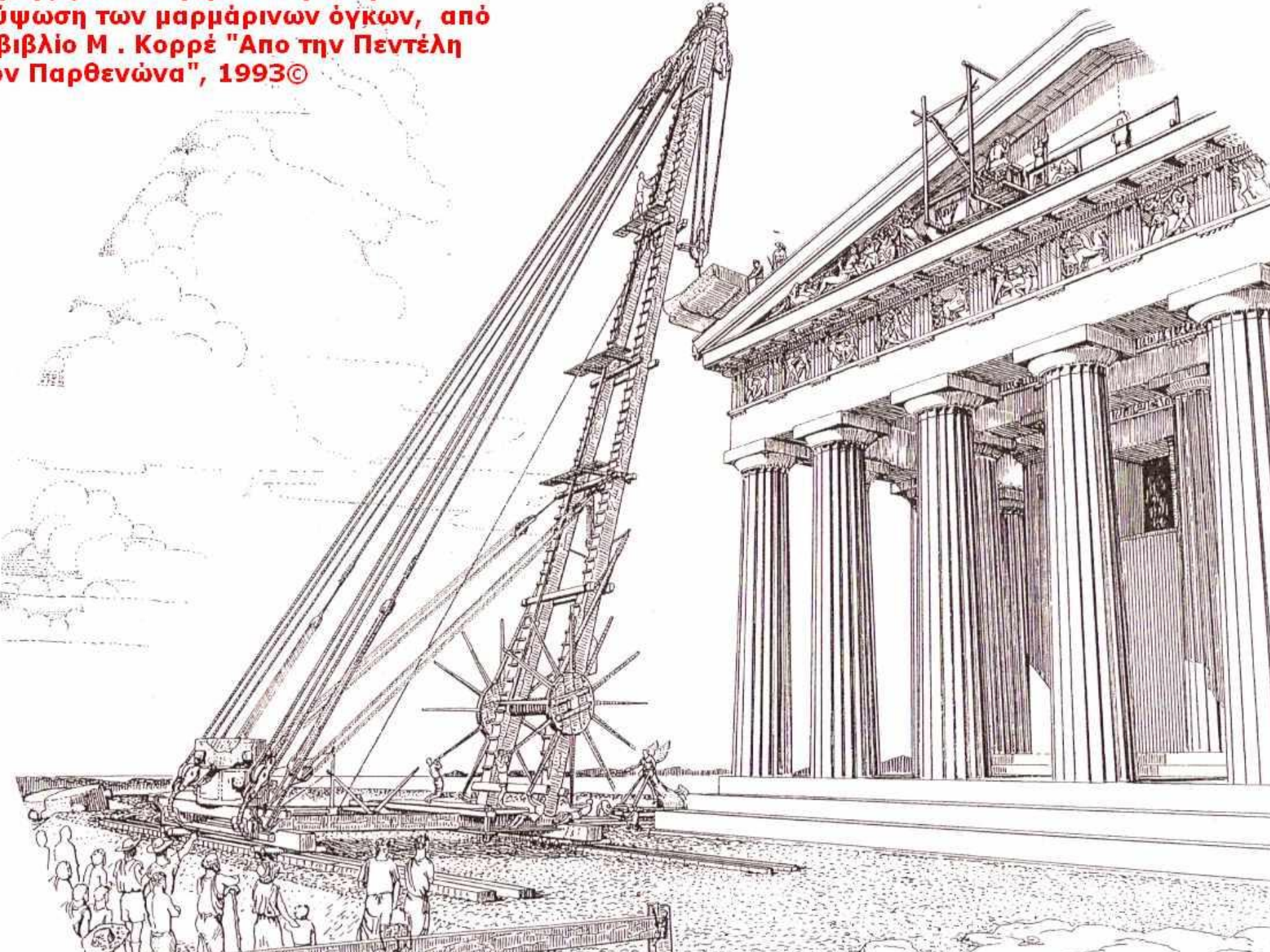



# PULLEYS WITH BLOCKS

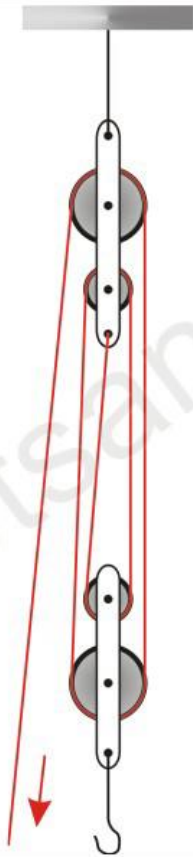







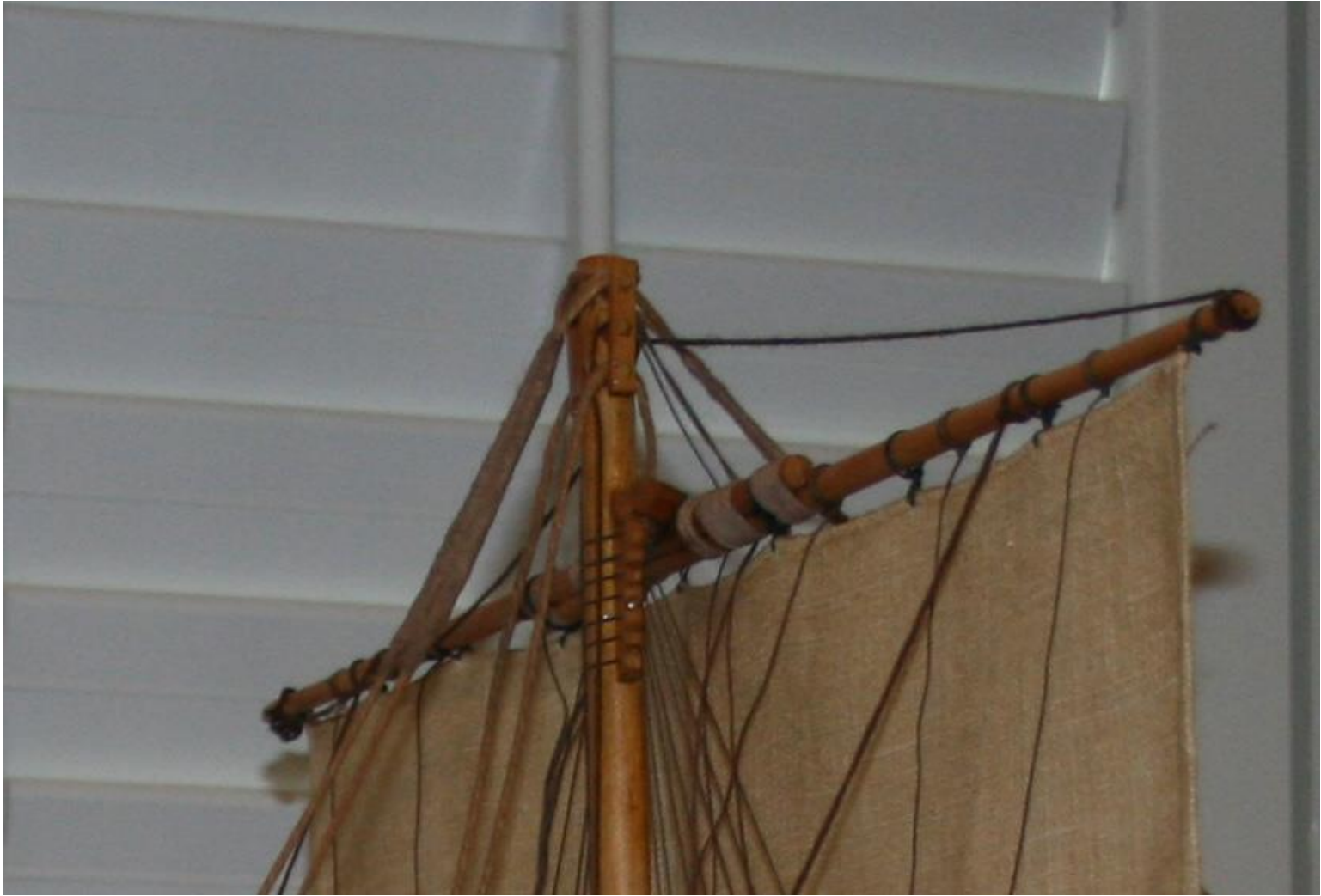

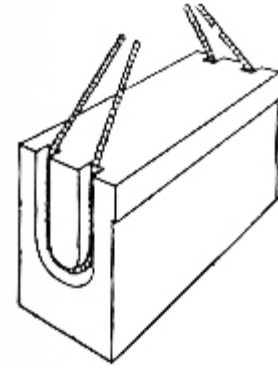



# LEWIS

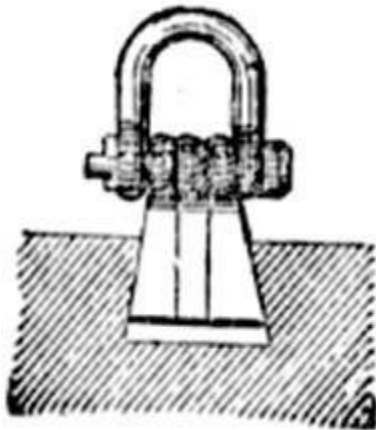
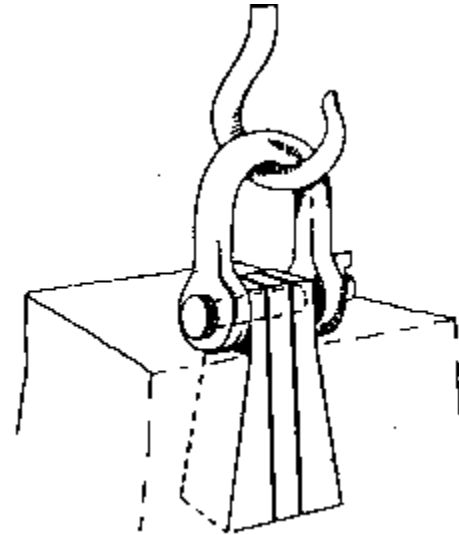
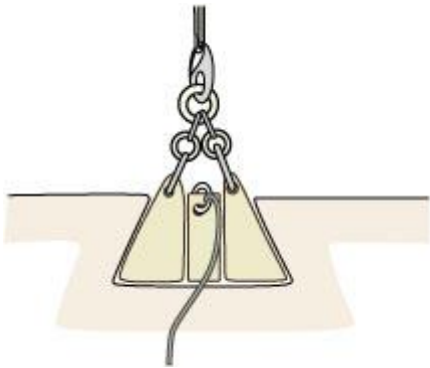

# CRAB

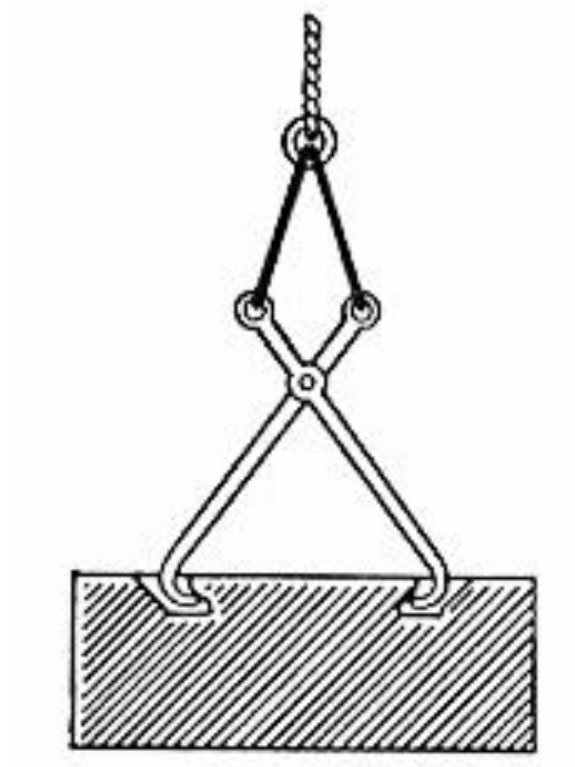

# LIFTING BOSSES

## NAXOS



# ZEUS TEMPLE AETOLIA





# APOLLO TEMPLE DIDYMA



## ΟΥΑΛ ΠΙΑZZA - ΓΕΡΑΣΑ



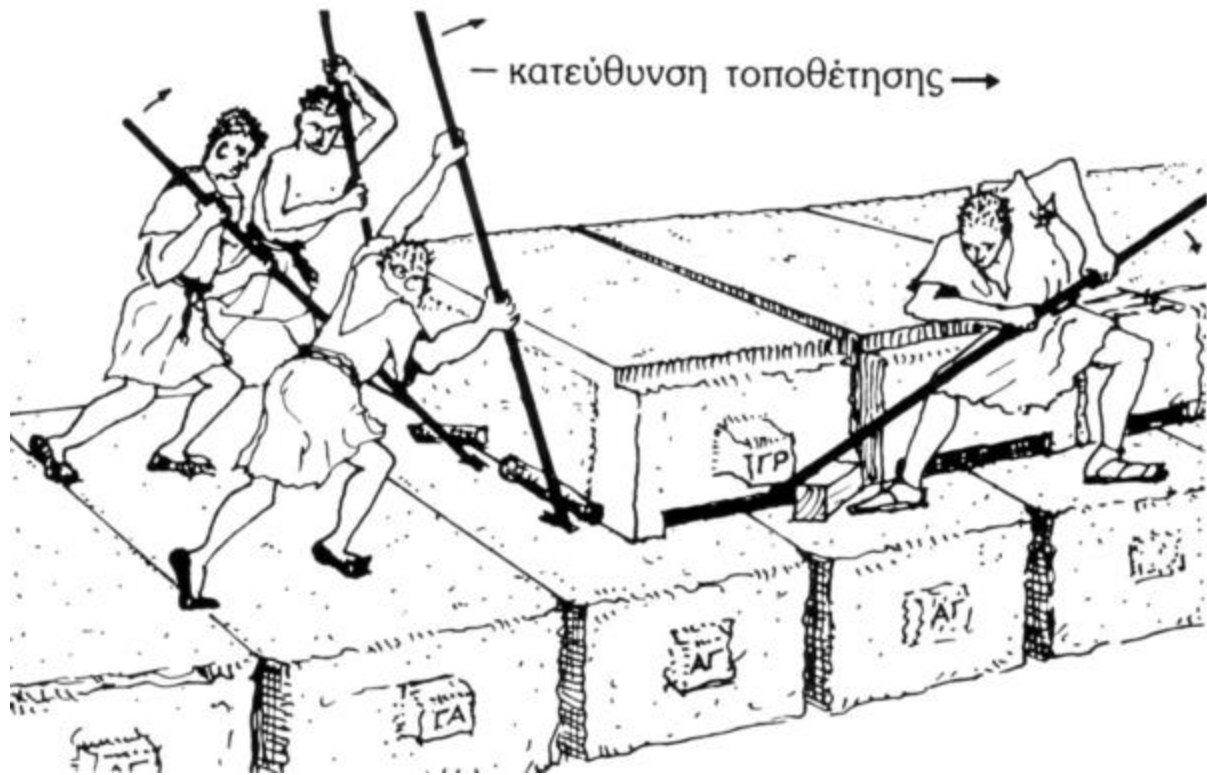

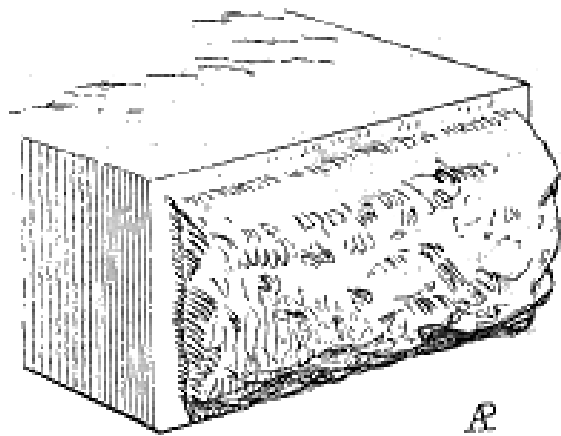

1







# PRYHOLES - CROWBARS

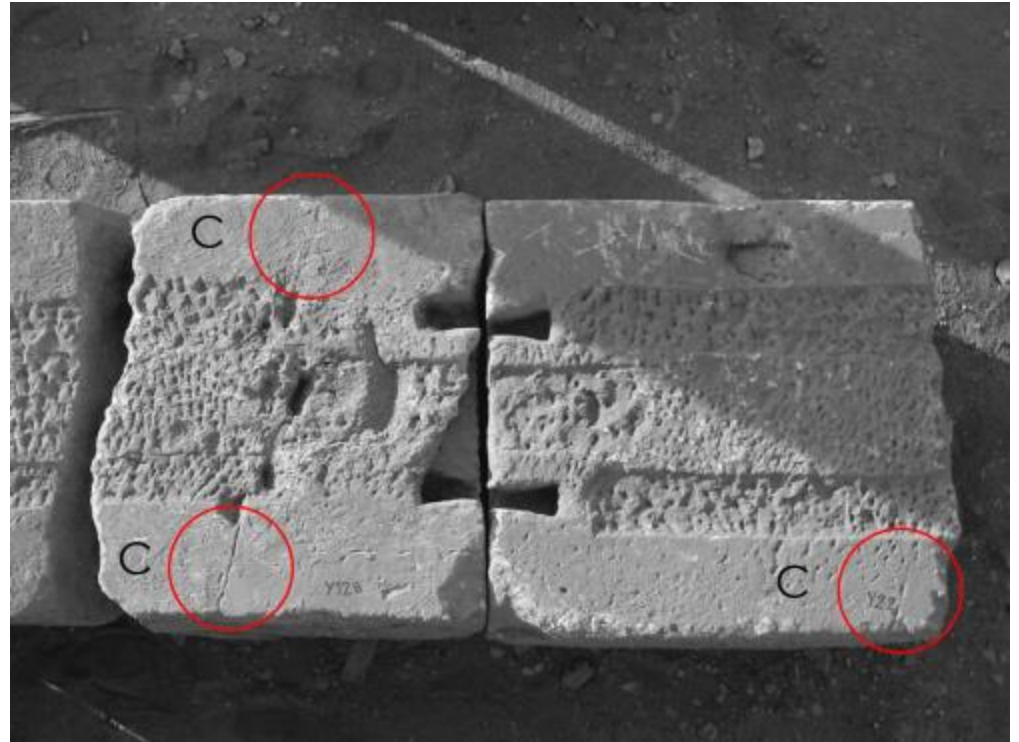
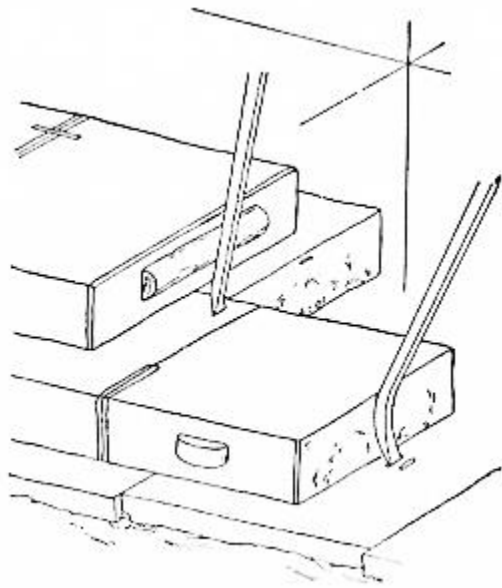

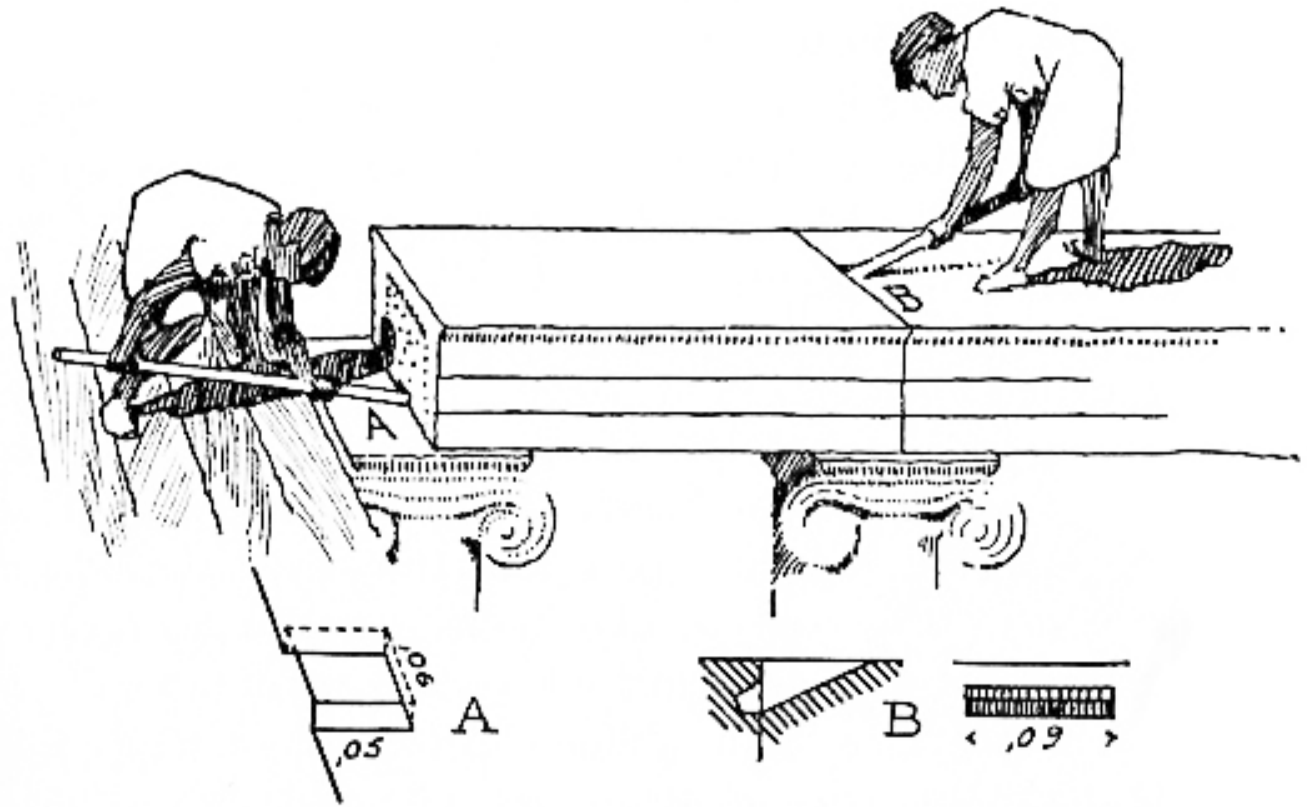



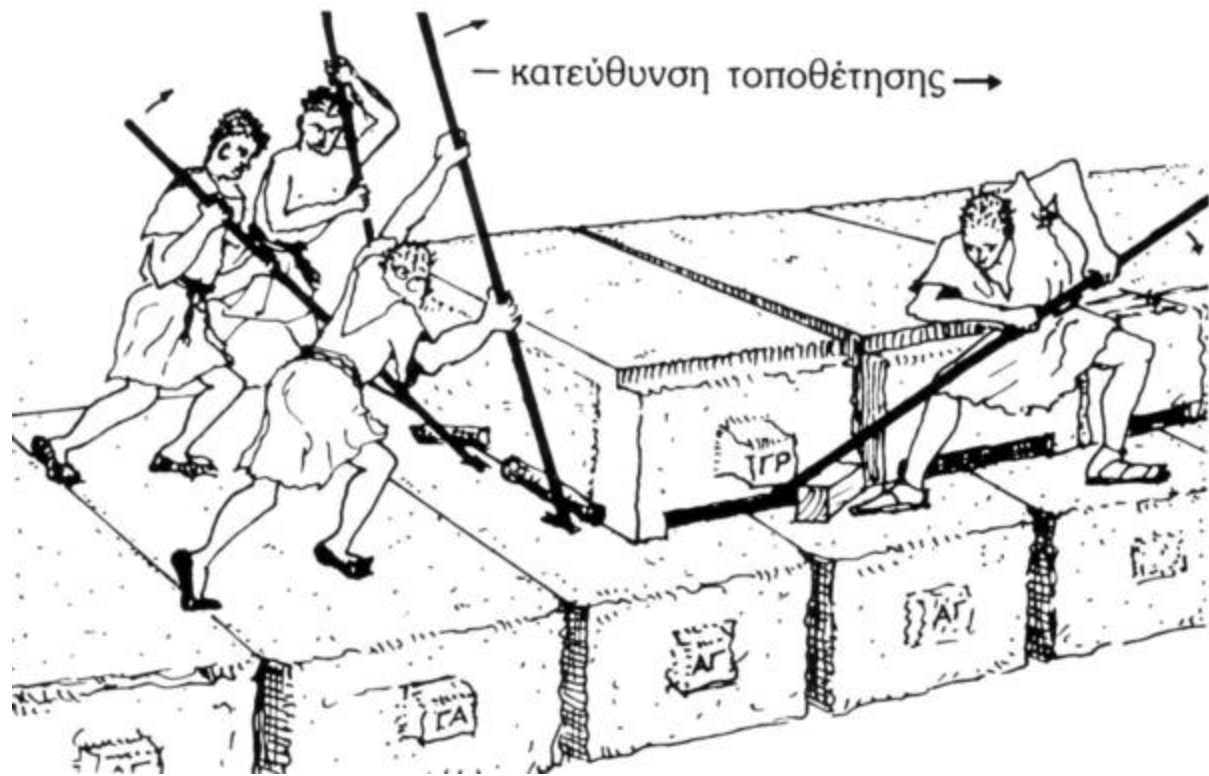

# CLAMPS

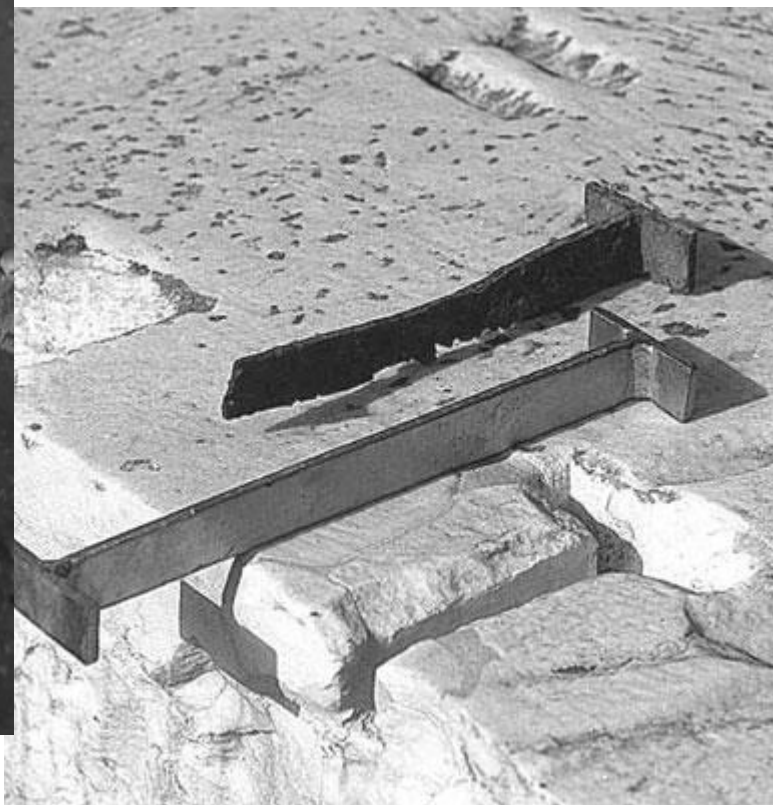
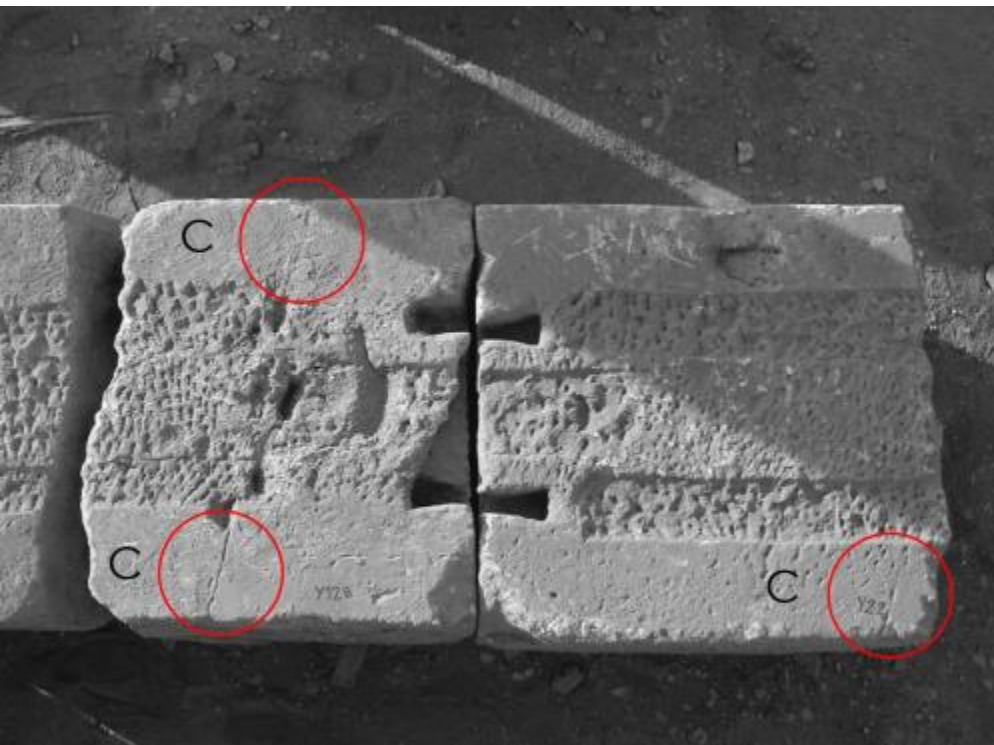

# DOWELS

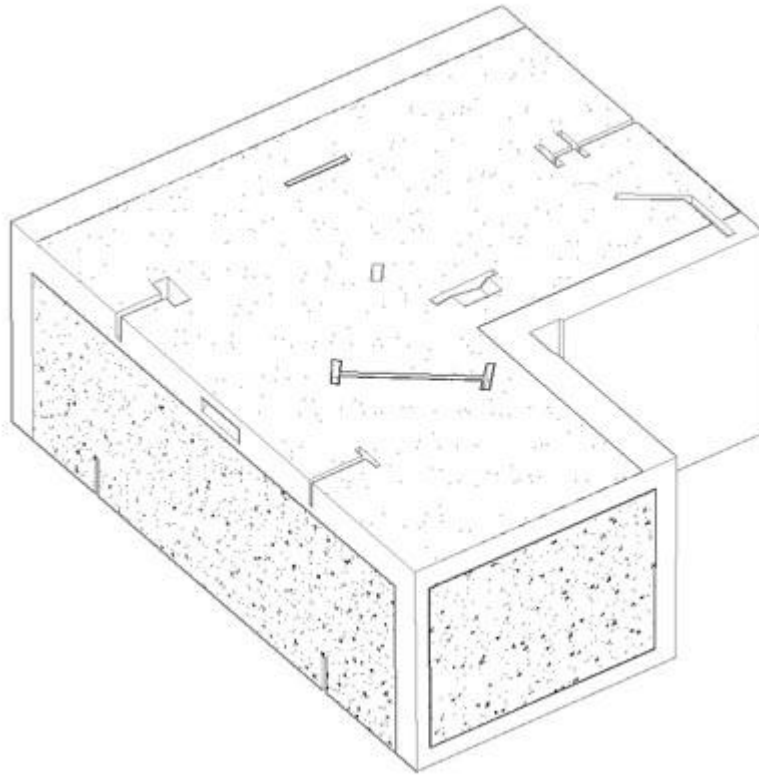

????

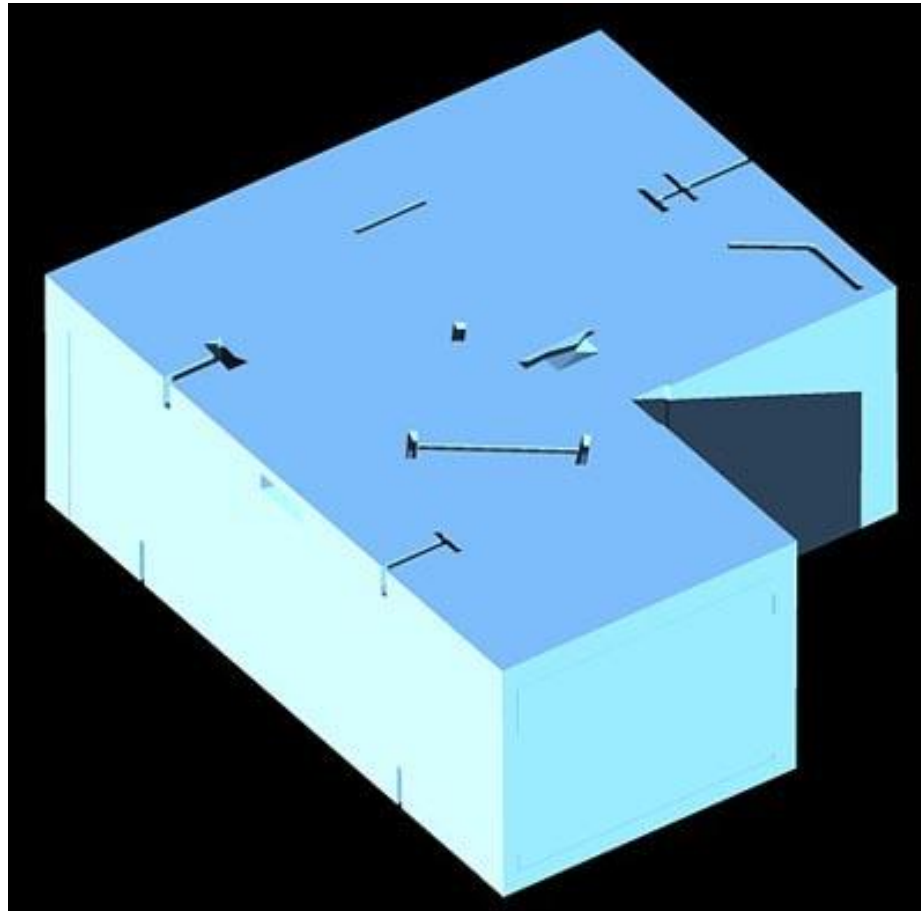

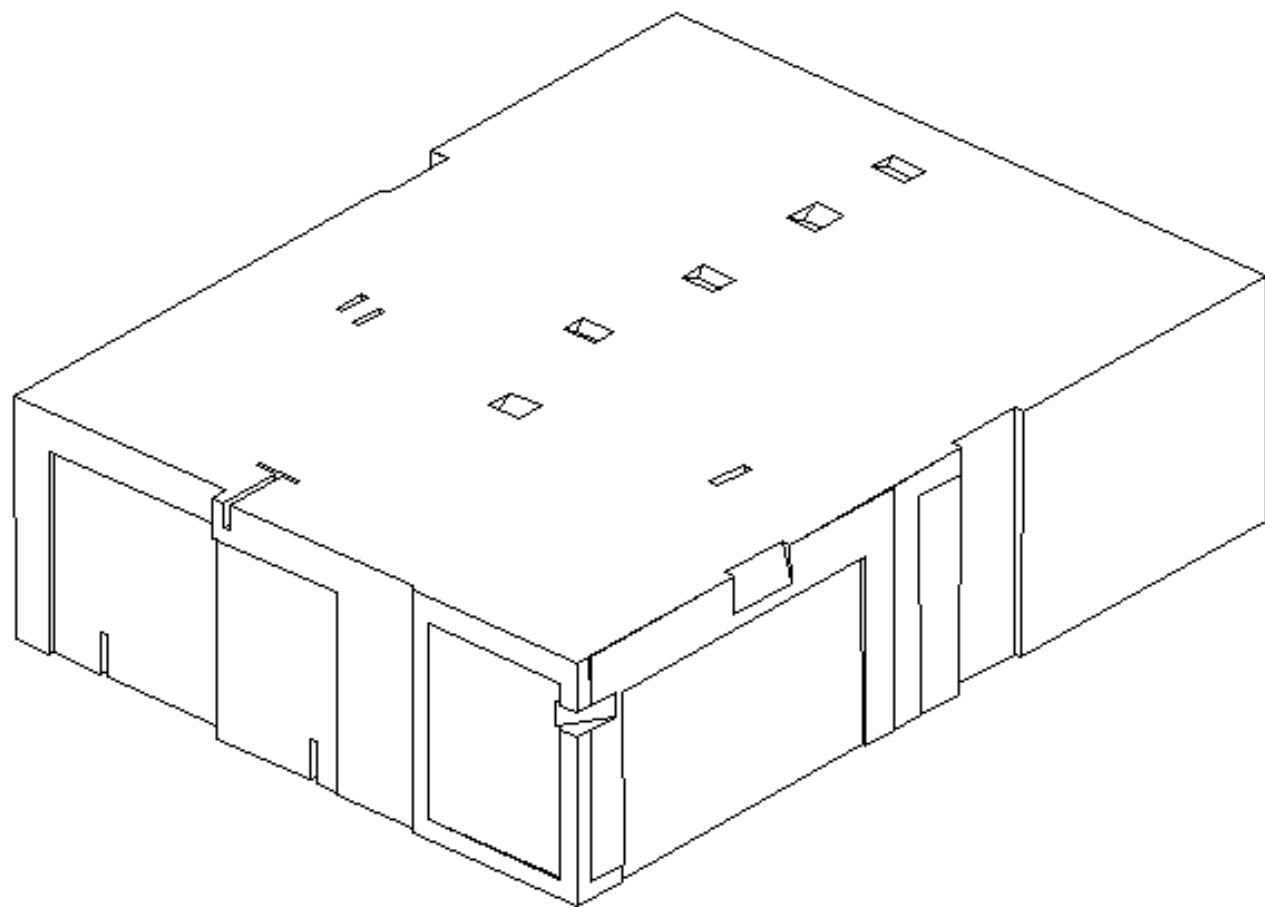



# EMPOLIA - PEGS

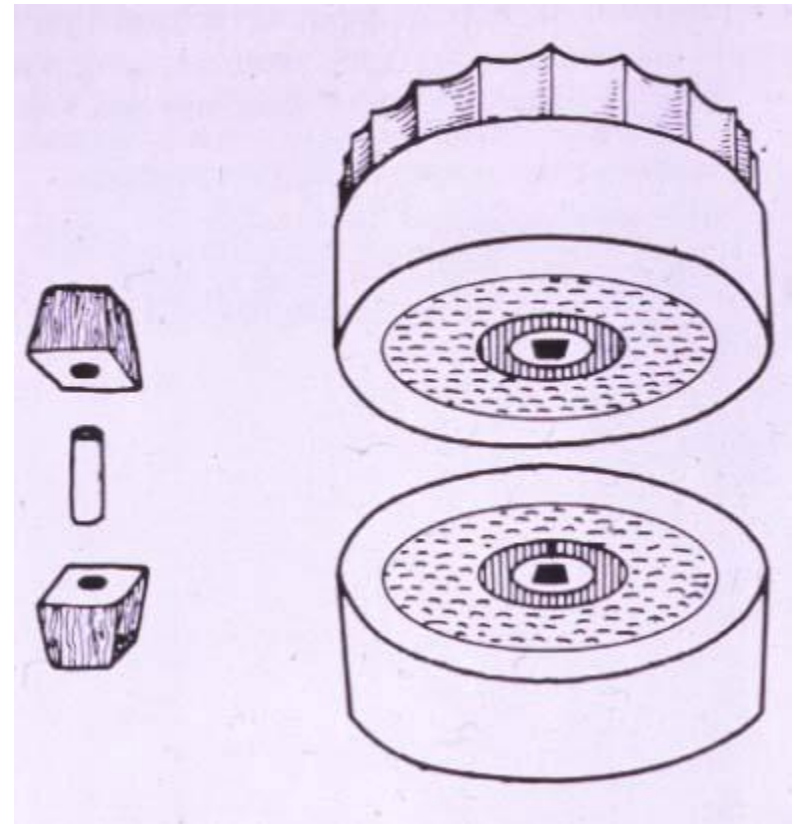
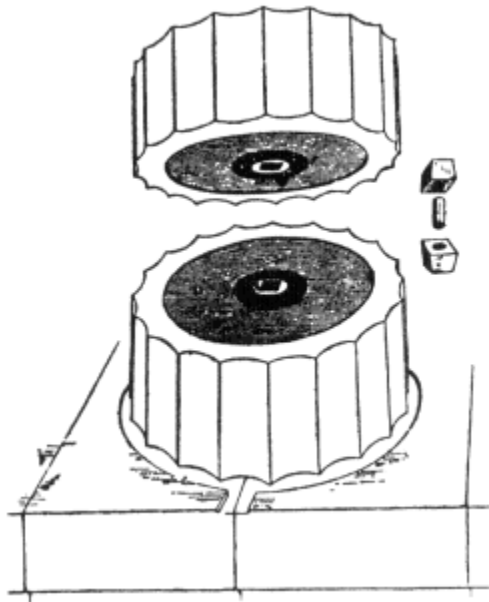





# “CLOACK”

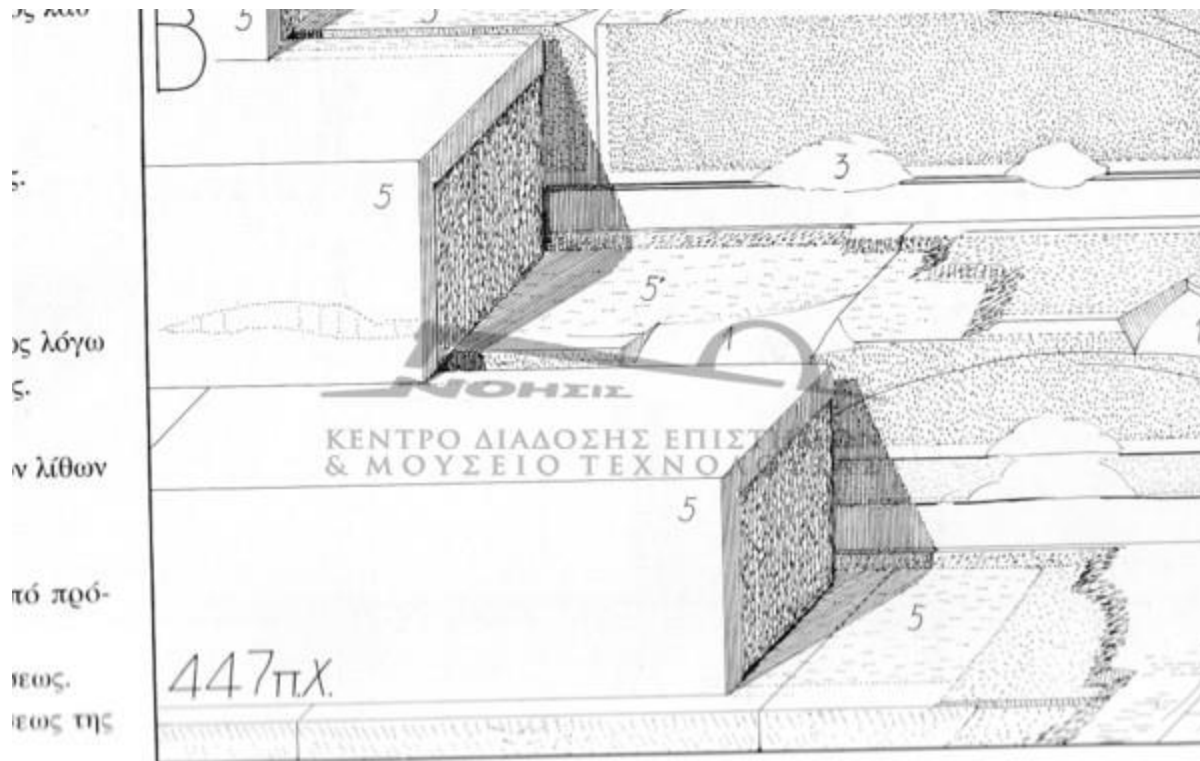

# ΝΑΟΣ ΤΟΥ ΑΠΟΛΛΩΝΑ ΣΤΑ ΔΙΔΥΜΑ



«φιλοκαλούμεν μετ' ευτελείας ... » Περικλής, *Επιτάφιος*.  
Th. Kalraxis, *Hemiteles*, 1986





# CARVING DOWN THE SHAFT

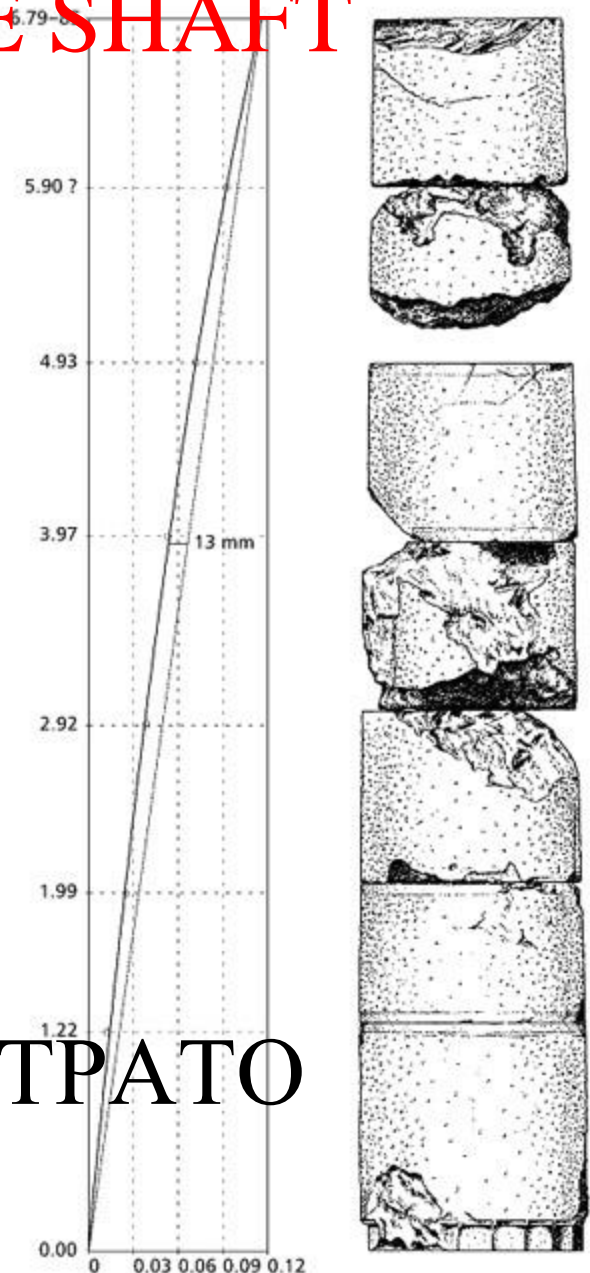

ΝΑΟΣ ΤΟΥ ΔΙΟΣ ΣΤΗ ΣΤΡΑΤΟ  
ΑΙΤΩΛΙΑΣ

# SEGESTA TEMPLE



# PROPARTHENON



# ANATHYROSIS BAND OF CONTACT

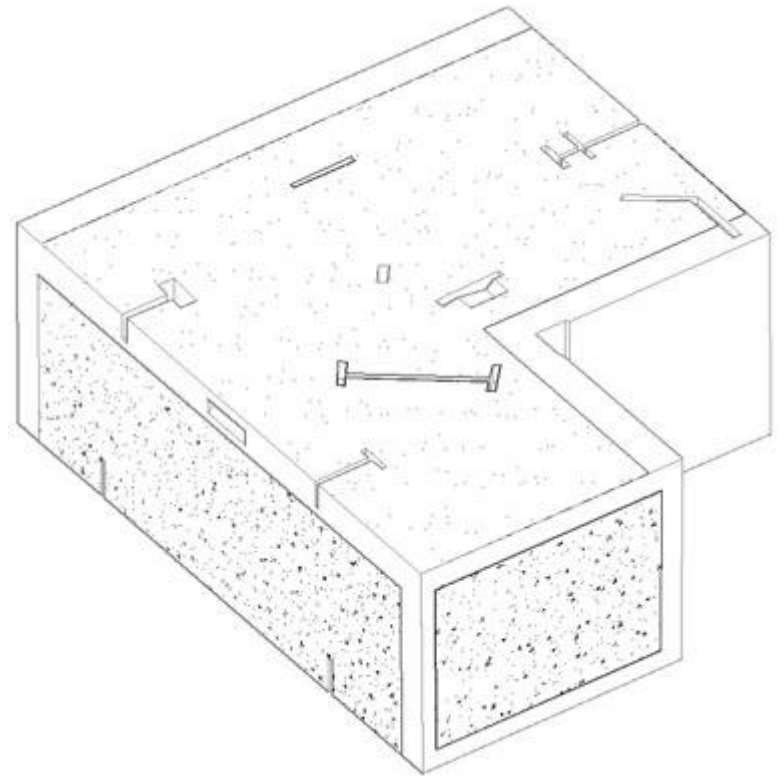



# + SLOPING JOINTS

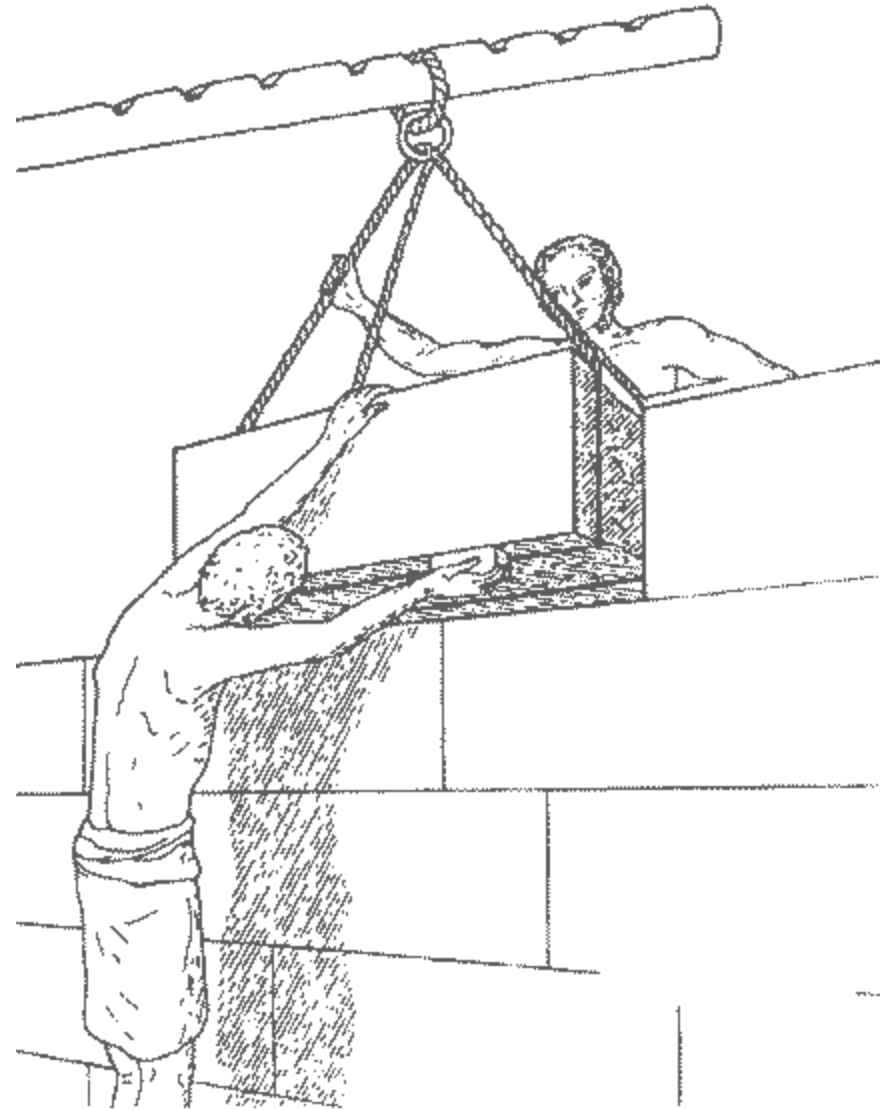
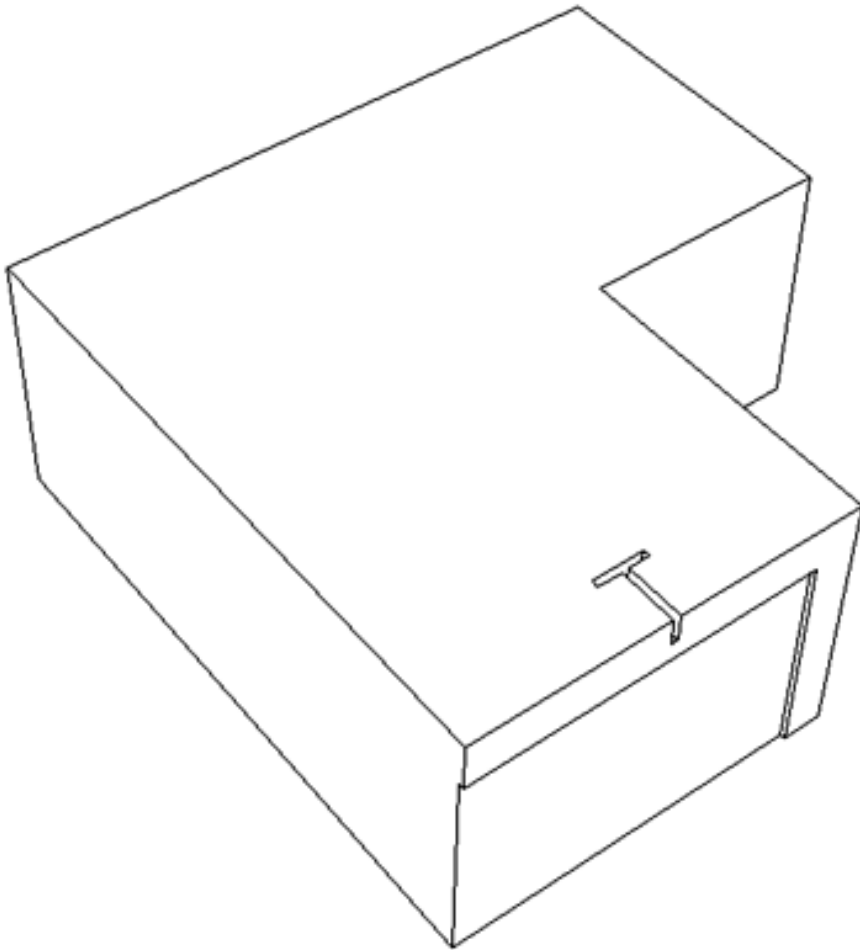

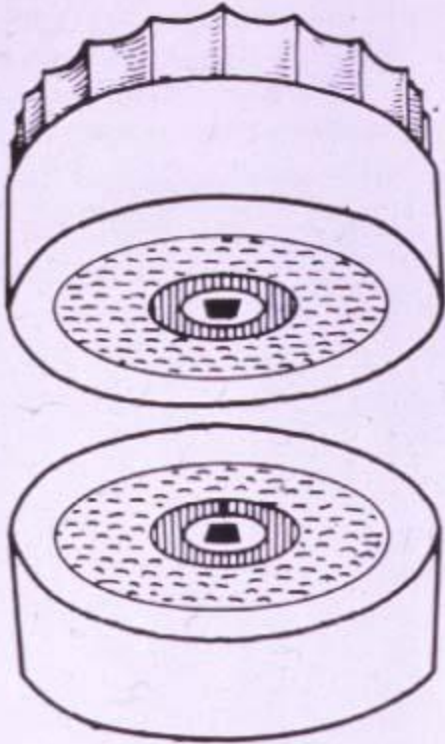
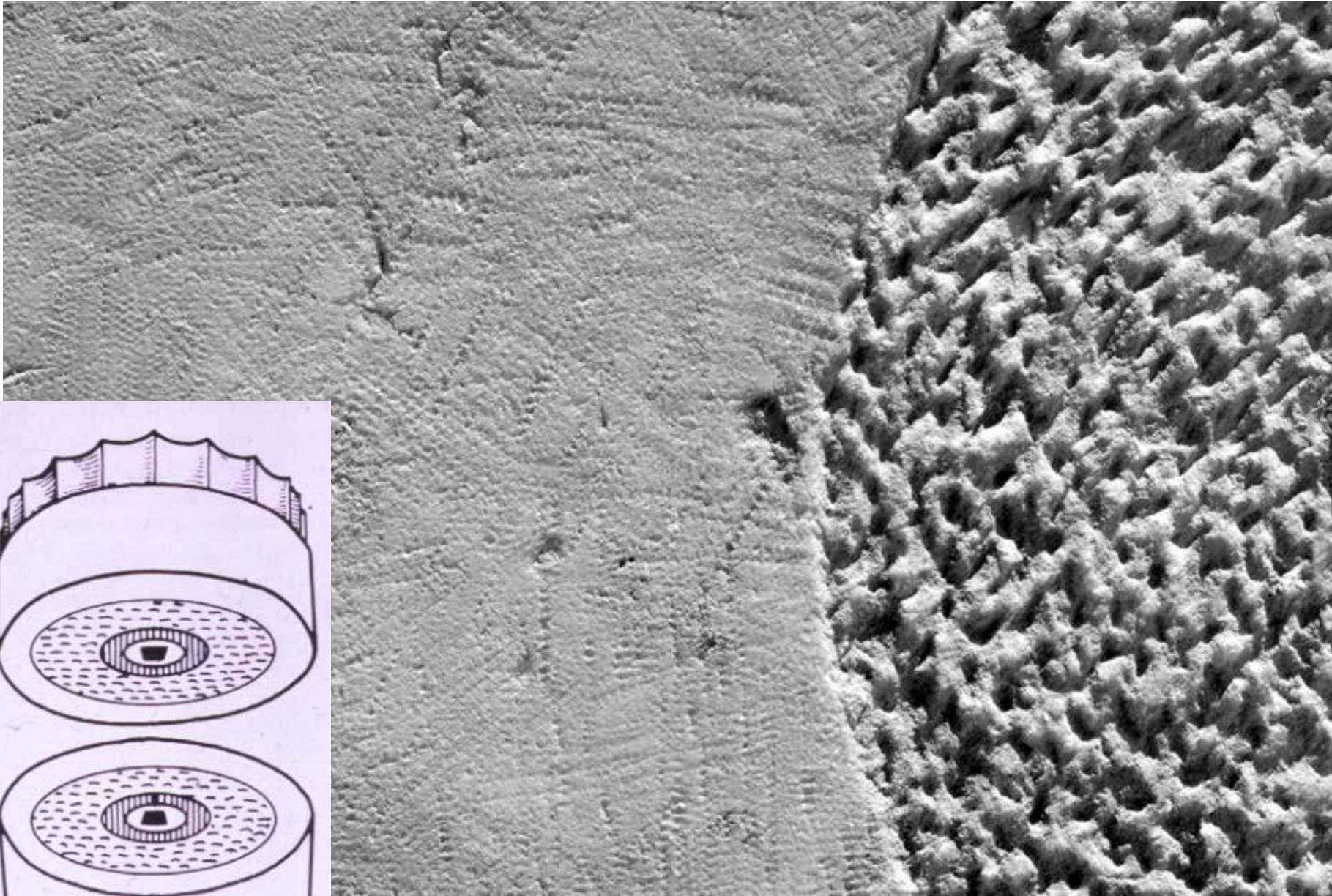



4



3

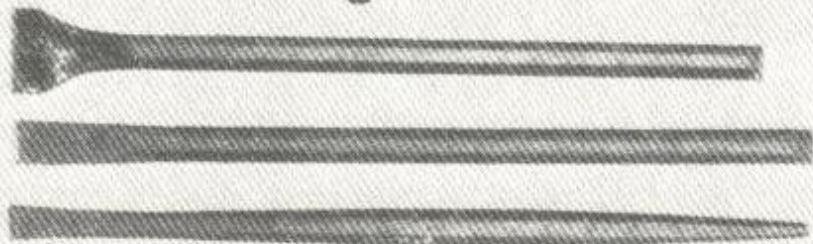

2

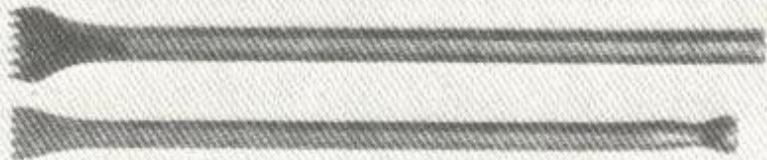

1



6



5

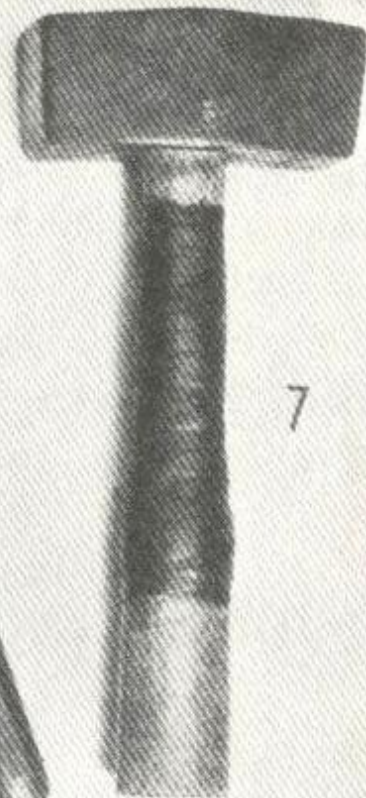

7

# MASONS' TOOLS

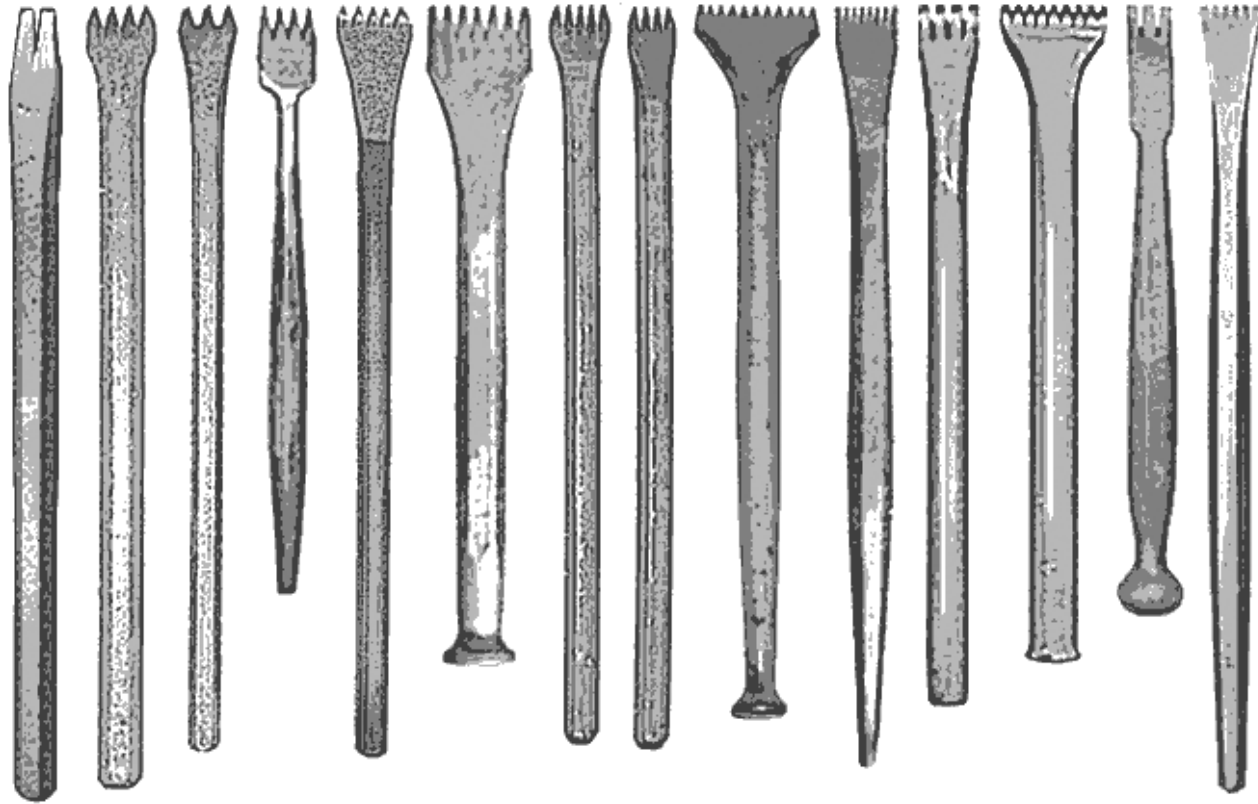

# ROMAN TOOLS



# PIQUE



www.shutterstock.com · 101612950

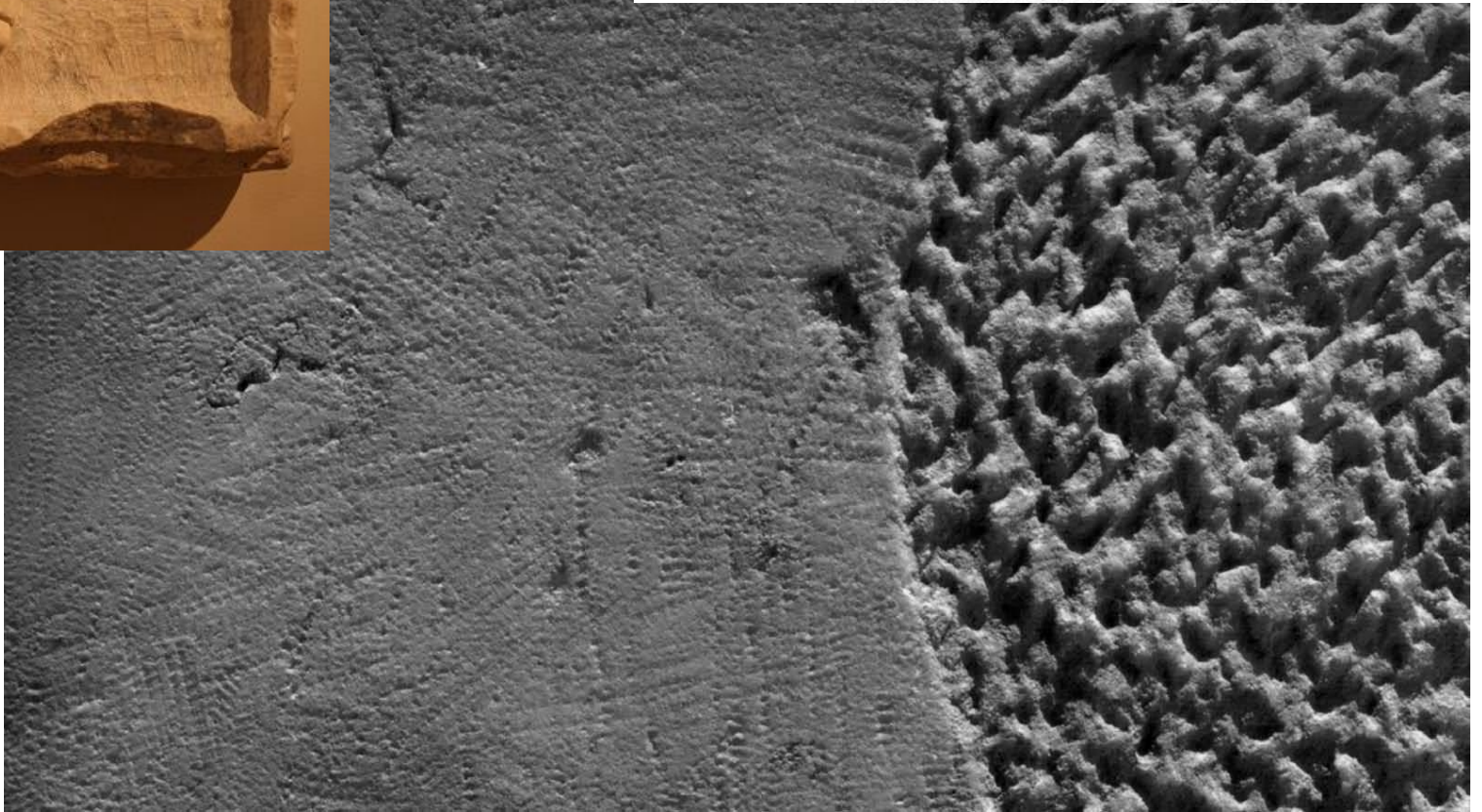









©2001 Brandon Cline



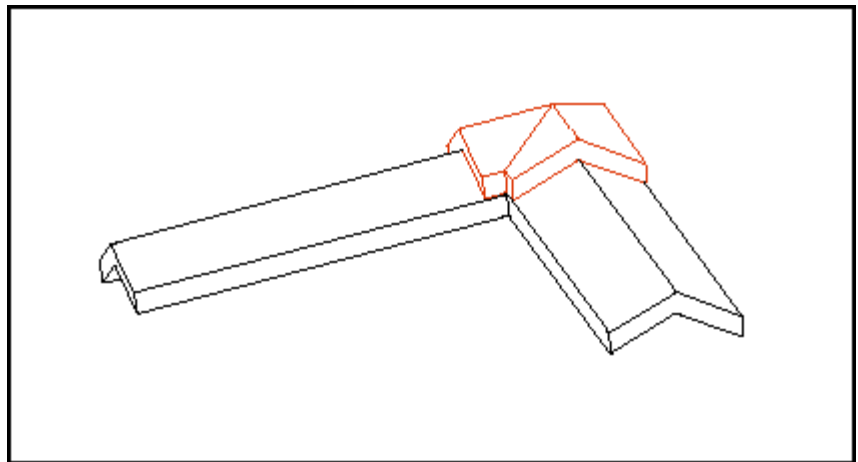
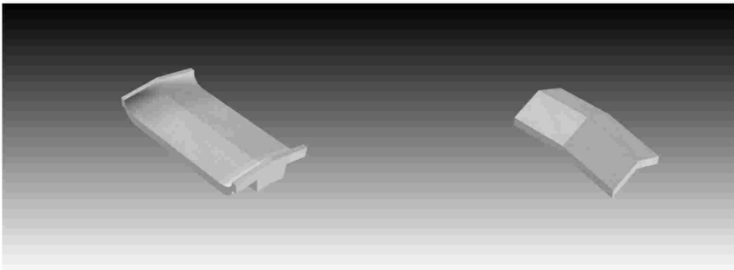
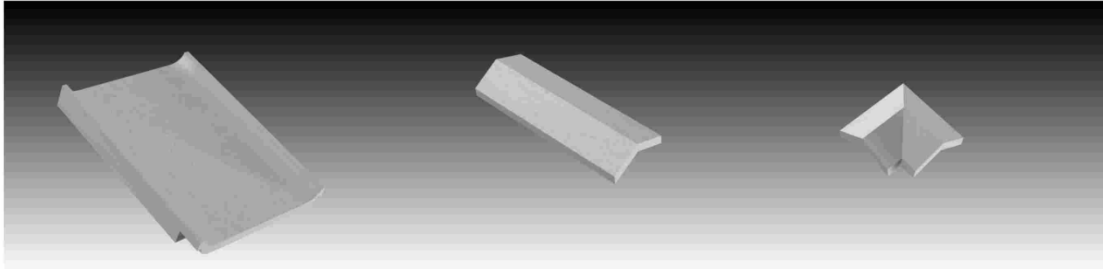
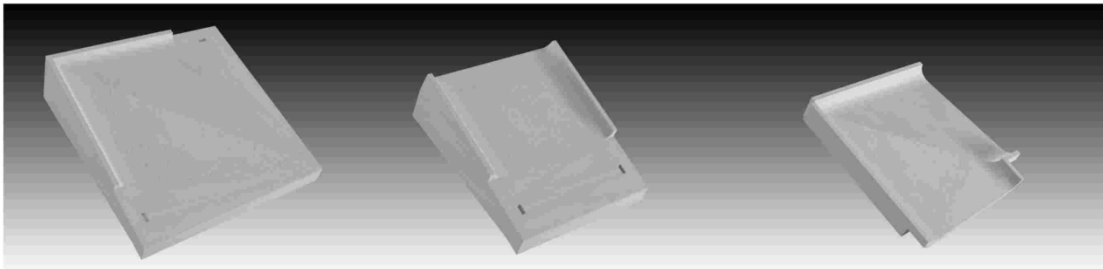



**ΛΟΥΤΡΑ ΑΓΟΡΑΣ.  
ΣΤΑΒΙΑ**











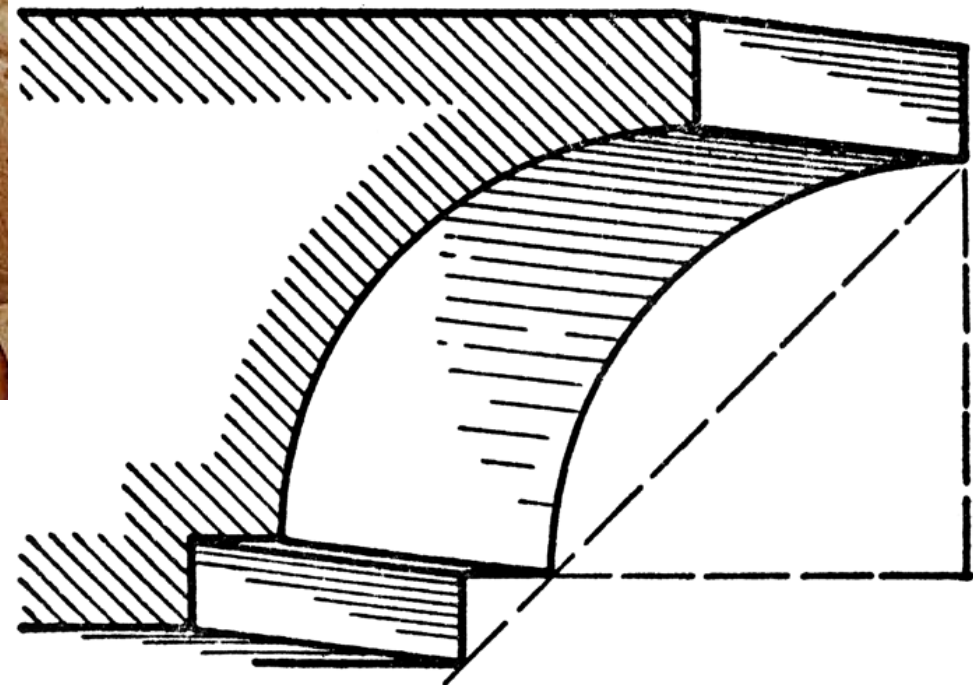
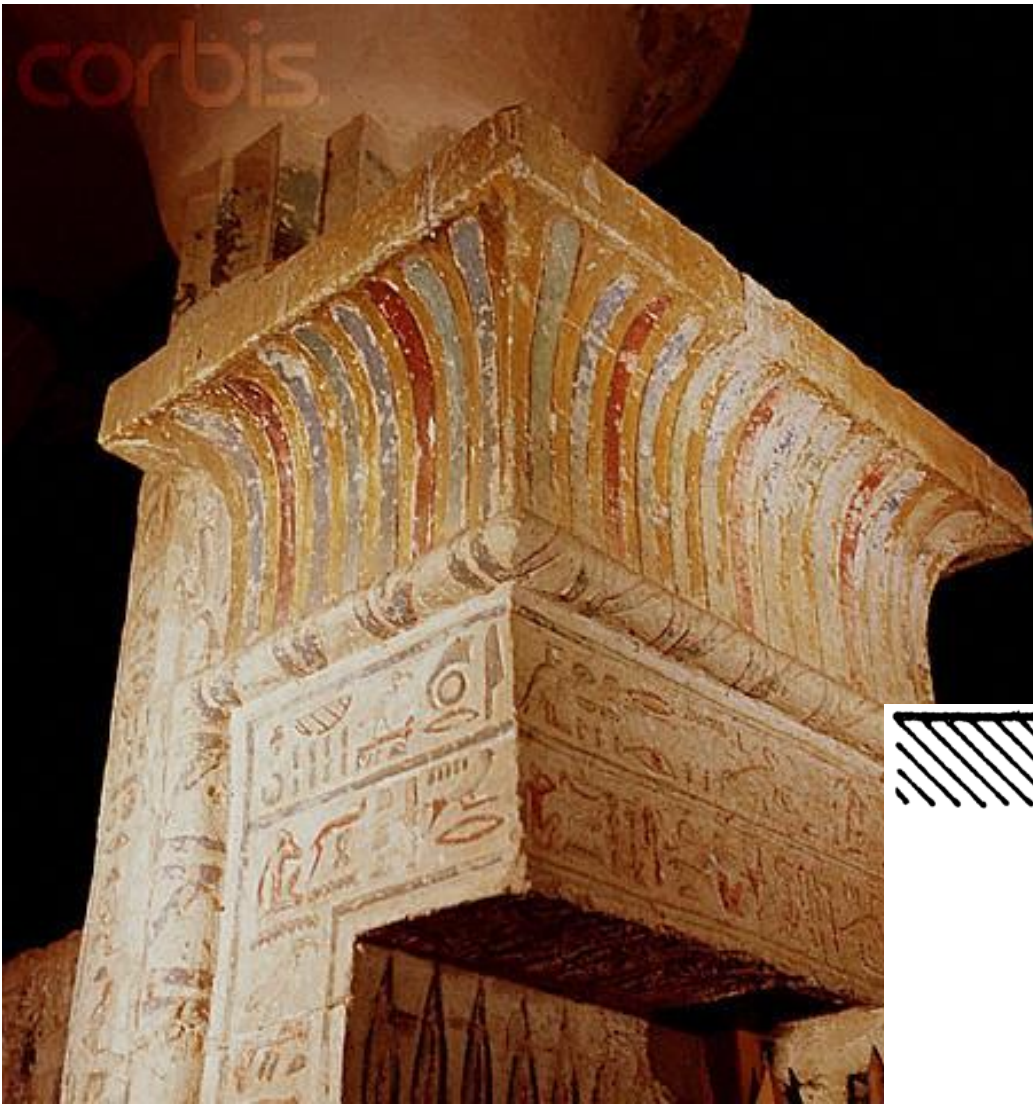

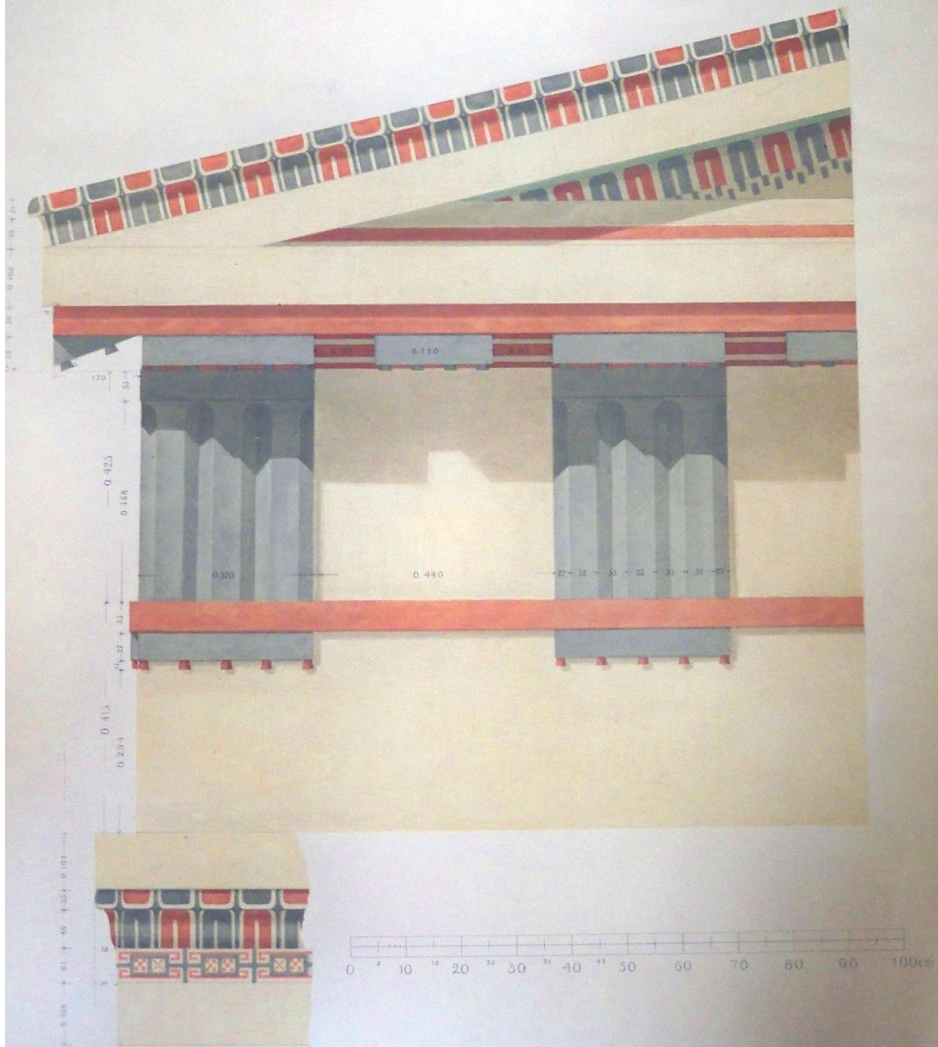

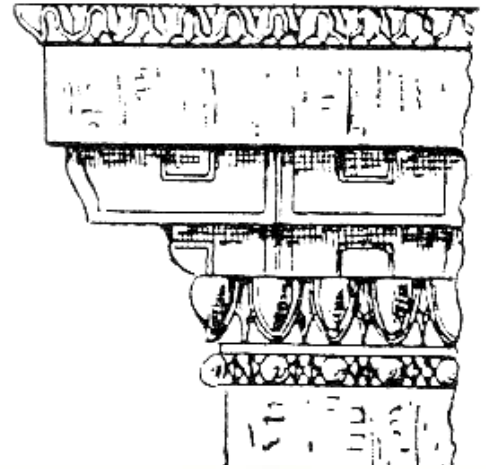
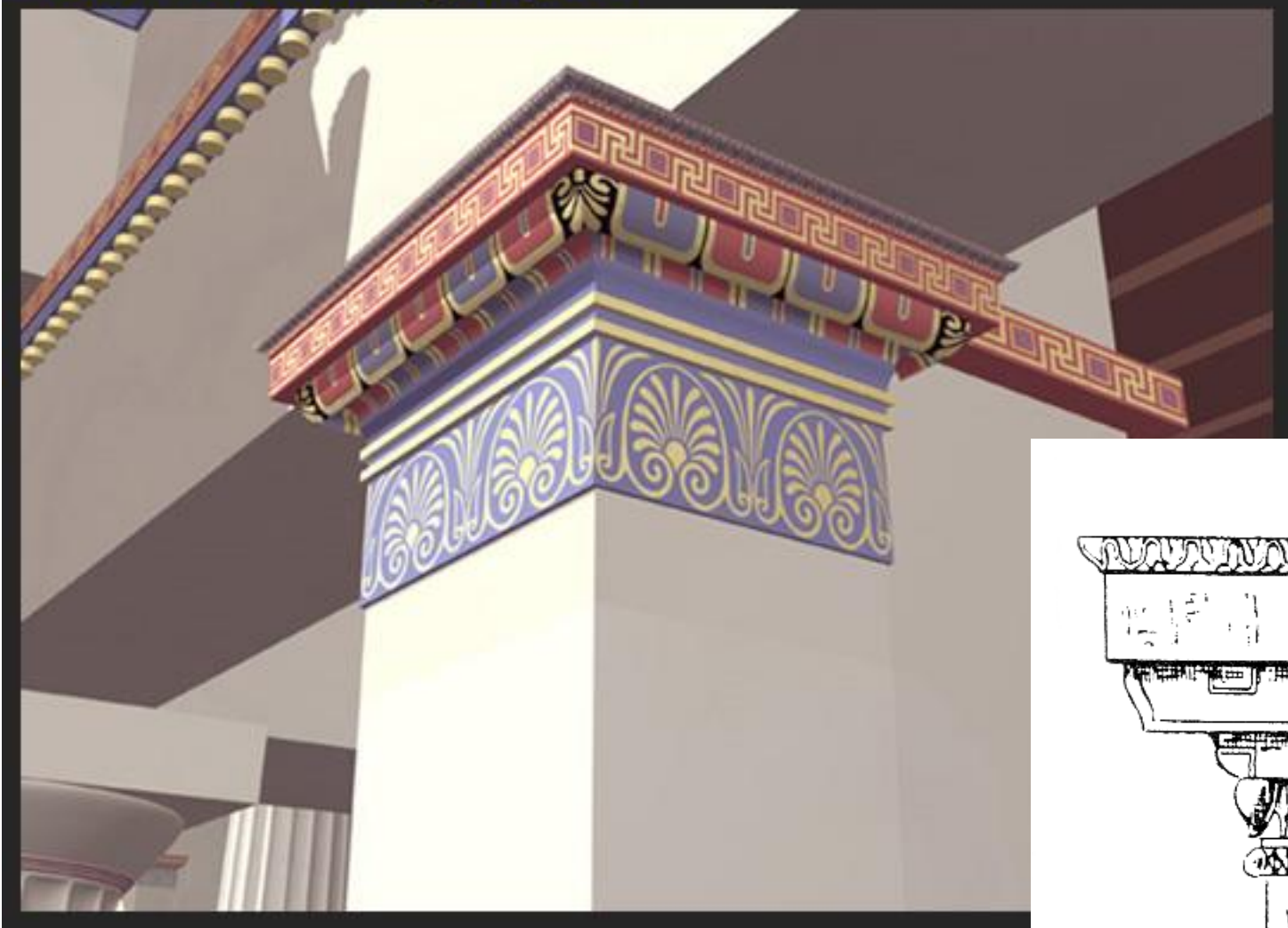

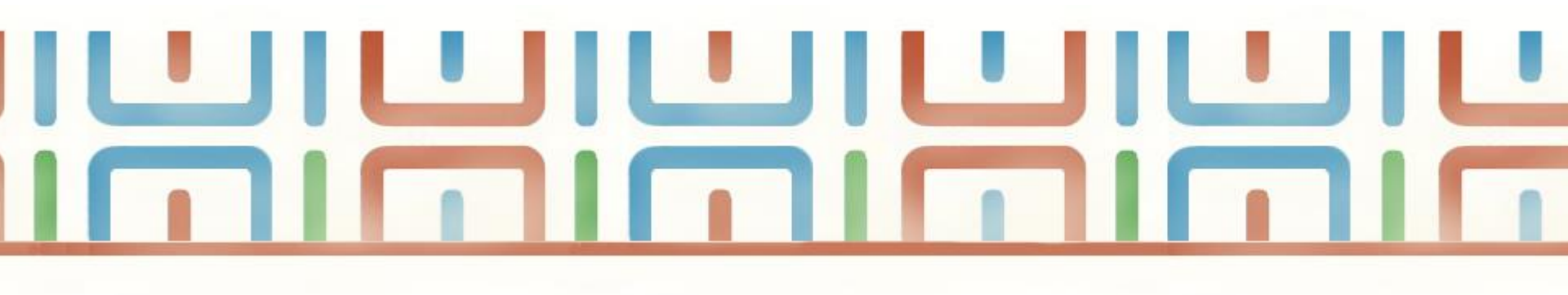

- ΑΙΓΥΠΤΙΑΚΟ GORGE
- CAVETTO
- ΚΟΙΛΟ ΚΥΜΑΤΙΟ
- ΤΕΤΑΡΤΟΚΥΚΛΙΚΗΣ ΔΙΑΤΟΜΗΣ
  
- ΗΑWKSΒΕΑΚ / ΒΕΑΚ
- ΔΩΡΙΚΟ ΦΥΛΛΟ
- ΡΑΜΦΟΣ

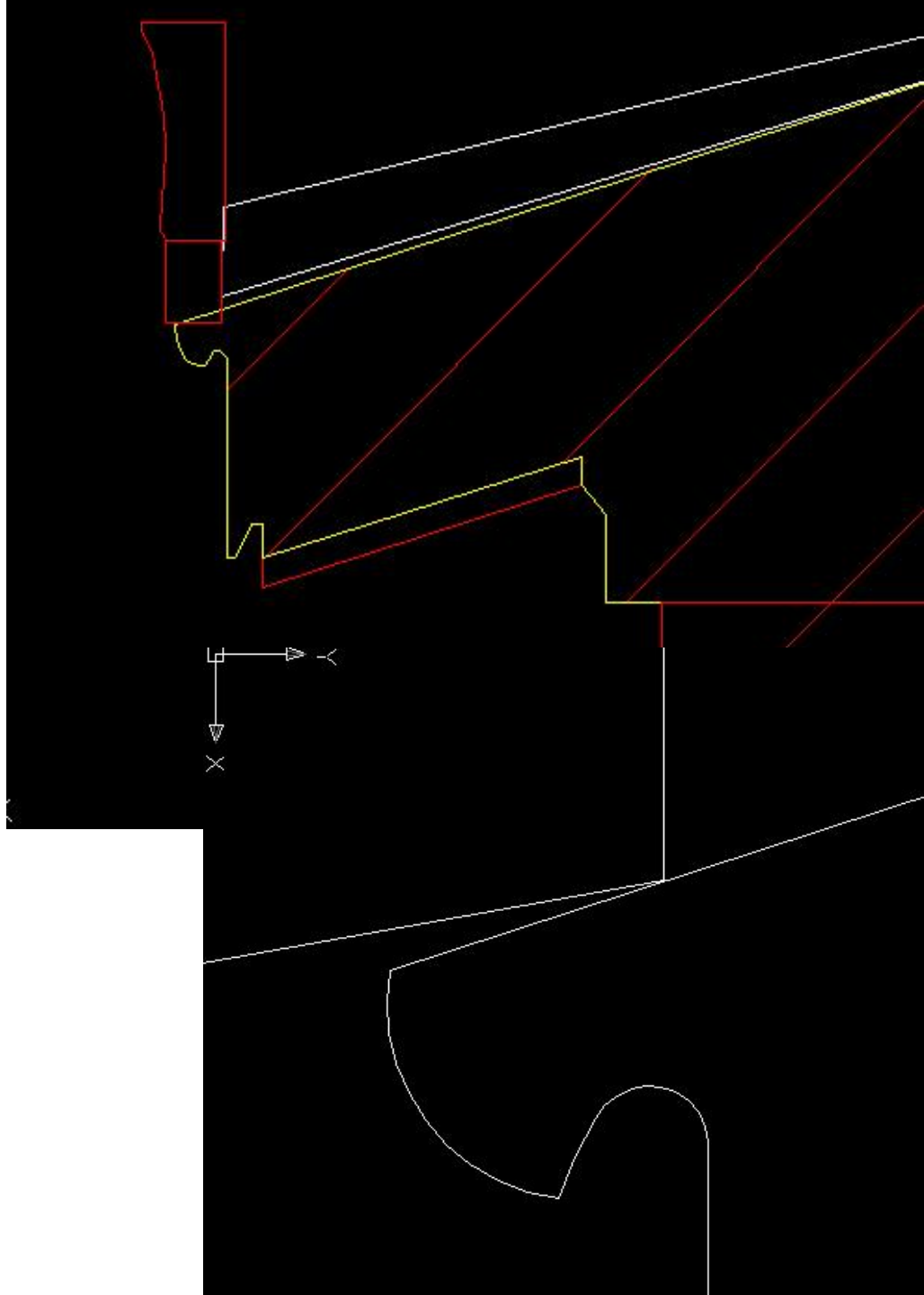
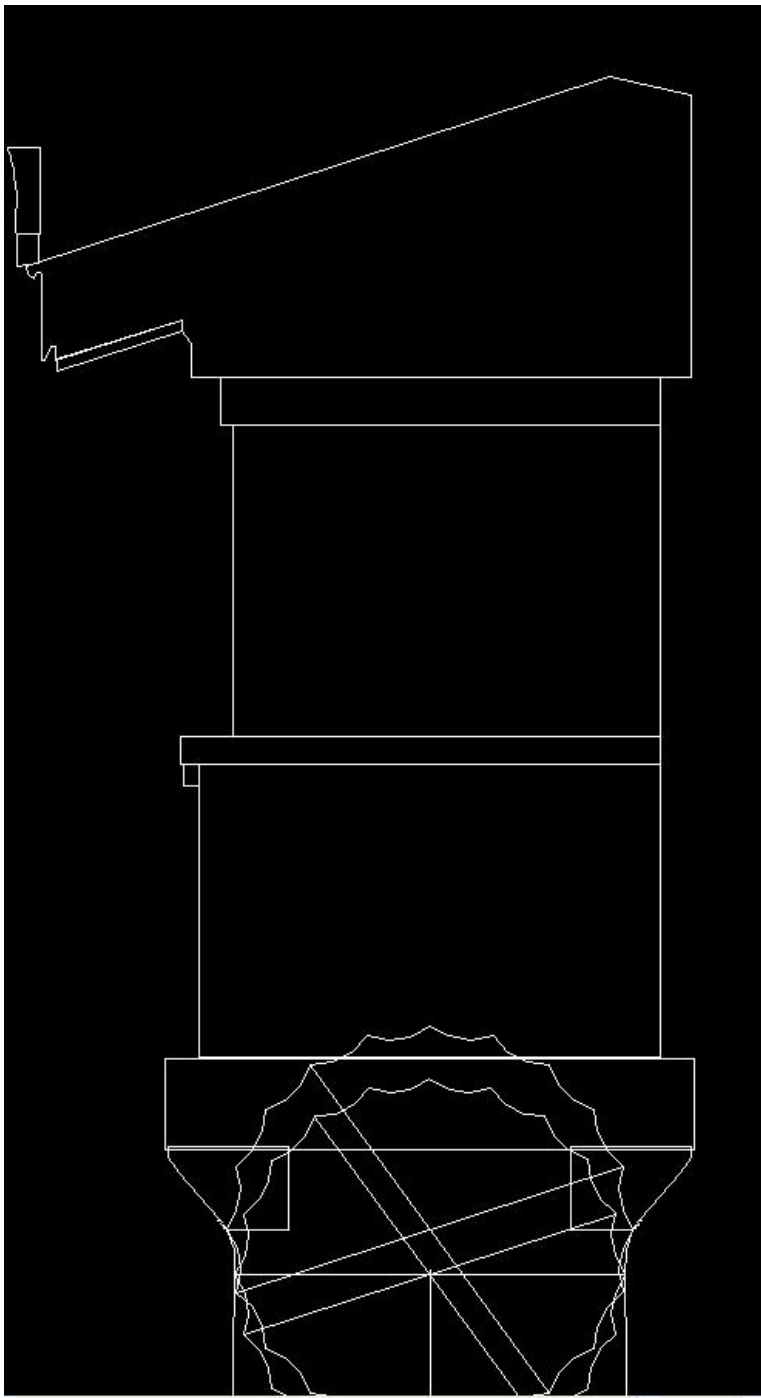

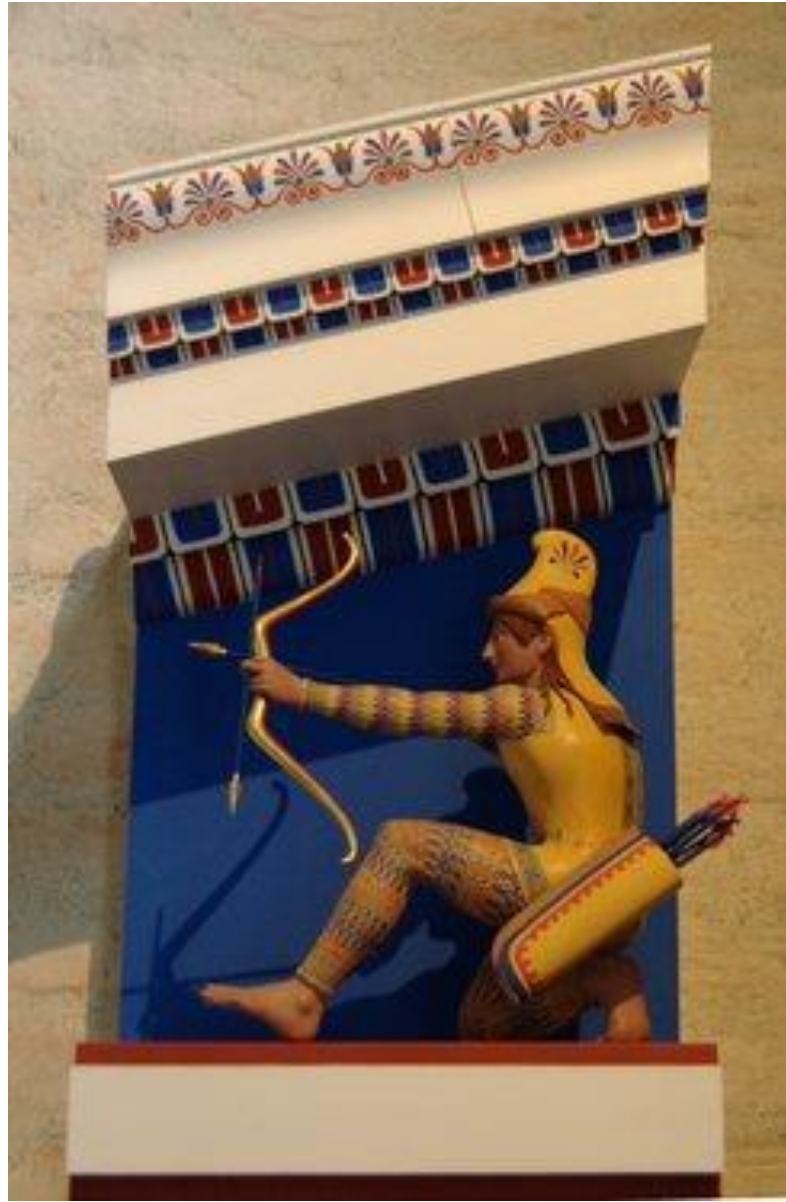





ΤΟ  
**ΡΑΜΦΟΣ**  
ΔΙΩΧΝΕΙ  
ΝΕΡΟ -  
ΜΑΖΕΥΕΙ  
ΣΚΙΑ









- CYMA RECTA
- ΚΥΜΑ
- ΚΟΙΛΟΚΥΡΤΟ ΚΥΜΑΤΙΟ
- ΣΙΓΜΟΕΙΔΕΣ
- CYMA REVERSA – ΑΝΑΣΤΡΟΦΟ
- HEART AND DART / ΚΑΡΔΙΑ ΚΑΙ ΛΟΓΧΗ
- **ΛΕΣΒΙΟ ΚΥΜΑΤΙΟ**







- ΟΥΟΛΟ
- ΑΣΤΡΑΓΑΛΟΣ
- ΩΟΝ ΜΕΤΑ ΛΟΓΧΗΣ
- **ΙΩΝΙΚΟ ΚΥΜΑΤΙΟ**





ΑΛΕΑ, ΤΕΓΕΑ







ΙΩΝΙΚΟ ΚΙΟΝΟΚΡΑΝΟ ΣΤΟ ΠΑΝΕΠΙΣΤΗΜΙΟ  
ΑΘΗΝΩΝ

## Ionic Capital



ΙΩΝΙΚΟ ΚΙΟΝΟΚΡΑΝΟ ΣΤΑ ΠΡΟΠΥΛΑΙΑ ΤΩΝ  
ΑΘΗΝΩΝ. ΨΗΦΙΑΚΗ ΑΠΟΚΑΤΑΣΤΑΣΗ

- ΚΟΙΛΟΚΥΡΤΟ ΚΥΜΑΤΙΟ
- ΚΟΙΛΟ ΚΥΜΑΤΙΟ  
ΤΕΤΑΡΤΟΚΥΚΛΙΚΗΣ ΔΙΑΤΟΜΗΣ
- ΡΑΜΦΟΣ
- ΙΩΝΙΚΟ ΚΥΜΑΤΙΟ
- ΑΣΤΡΑΓΑΛΟΣ
- ΤΟΡΟΣ
- ΣΚΟΤΙΑ / ΤΡΟΧΙΛΟΣ

# ΕΙΔΗ ΚΥΜΑΤΙΩΝ

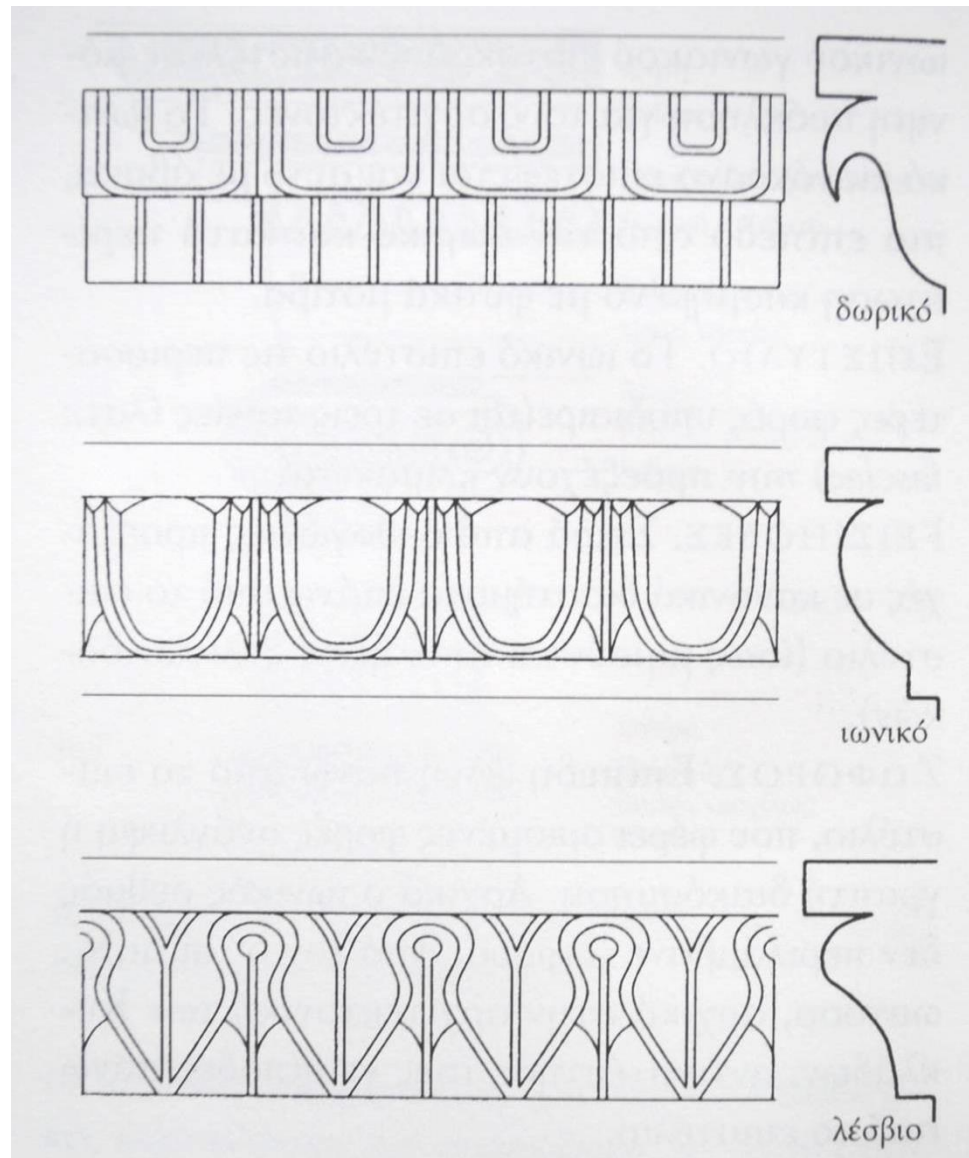

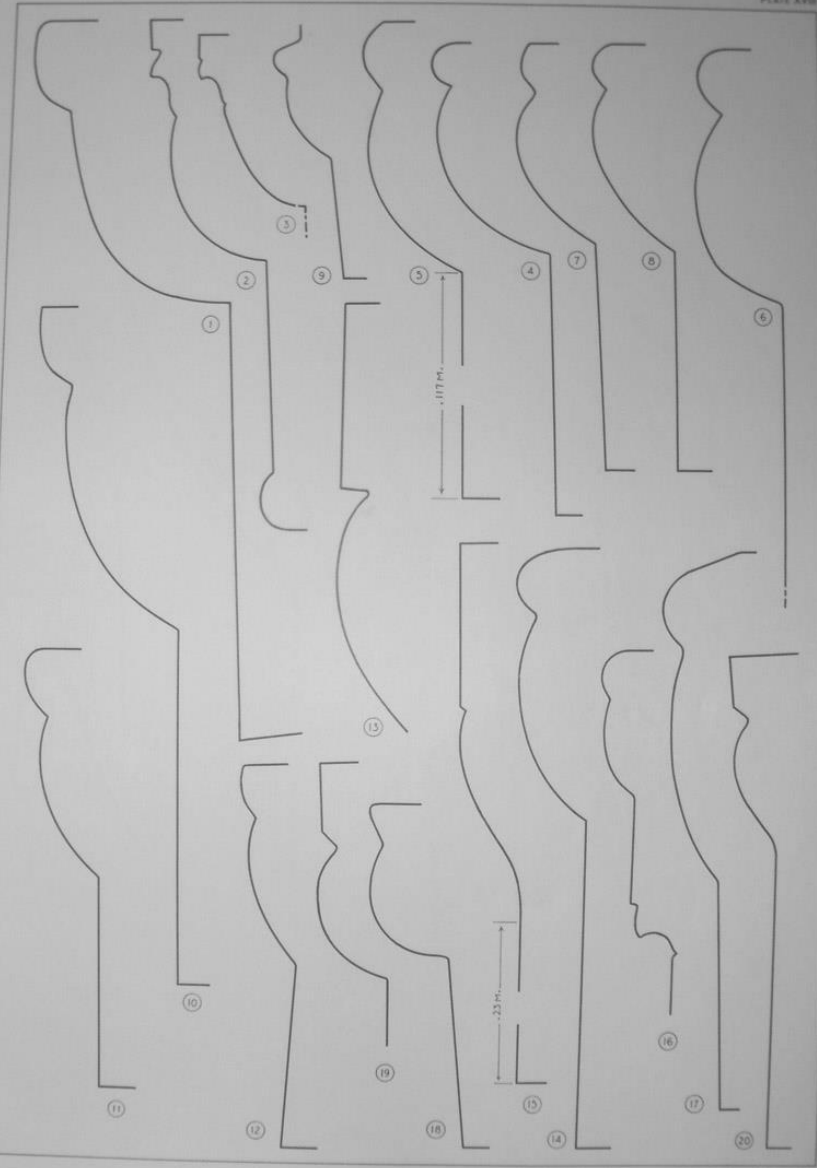

OVULO VII CORINTHIAN SIMA  
SIXTH CENTURY

FIFTH AND FOURTH CENTURIES

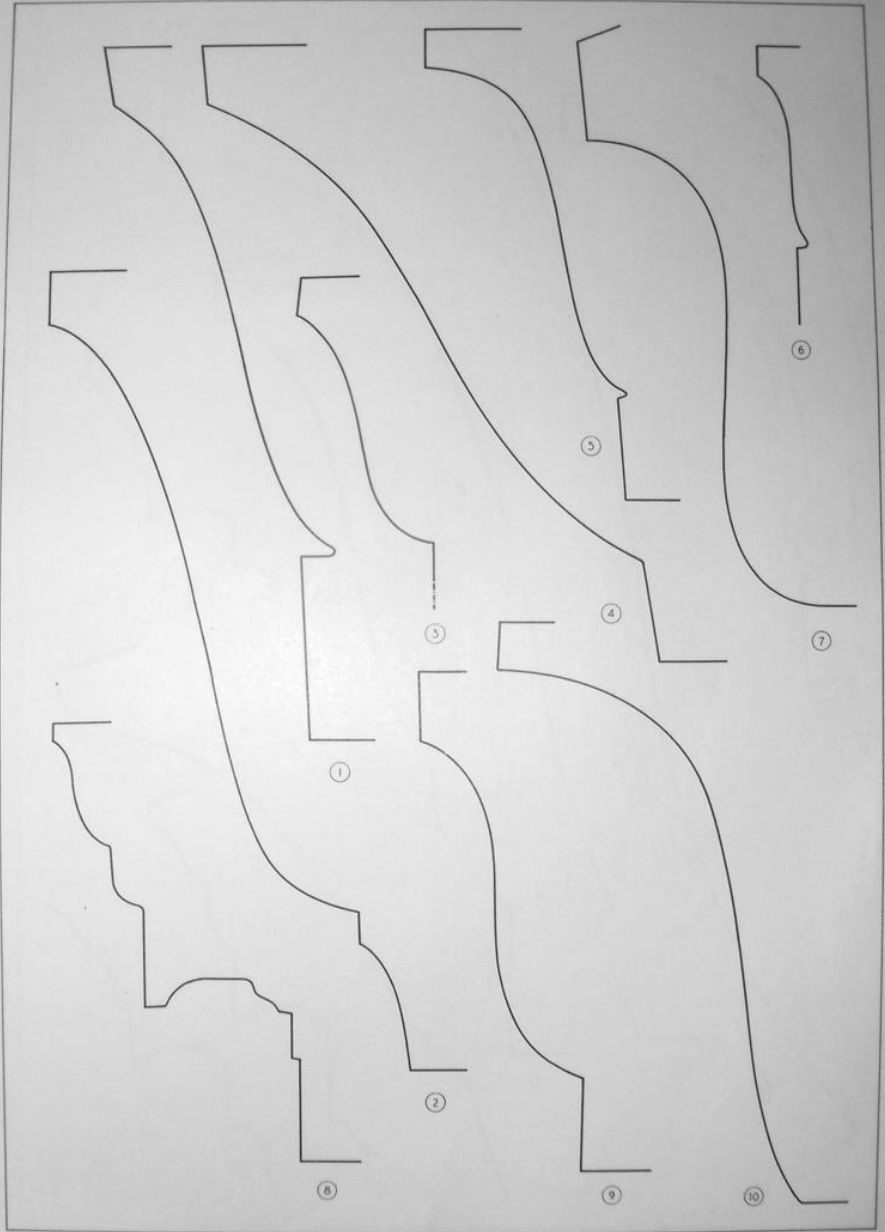

CYMA RECTA II SIMA  
FIFTH AND FOURTH CENTURIES





# ΛΕΟΝΤΟΚΕ ΦΑΛΕΣ

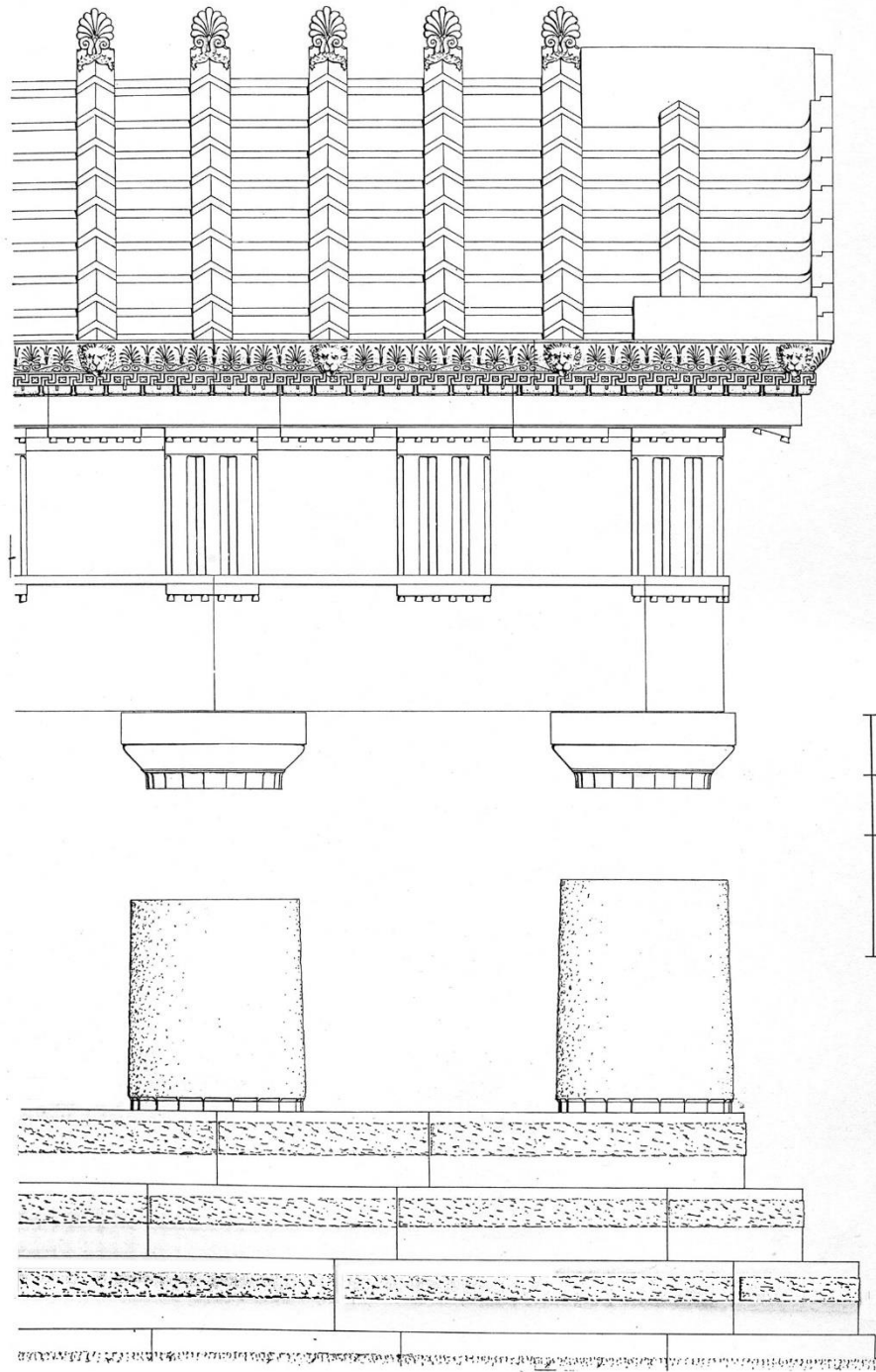

# THE AGORA OF GYTHEION

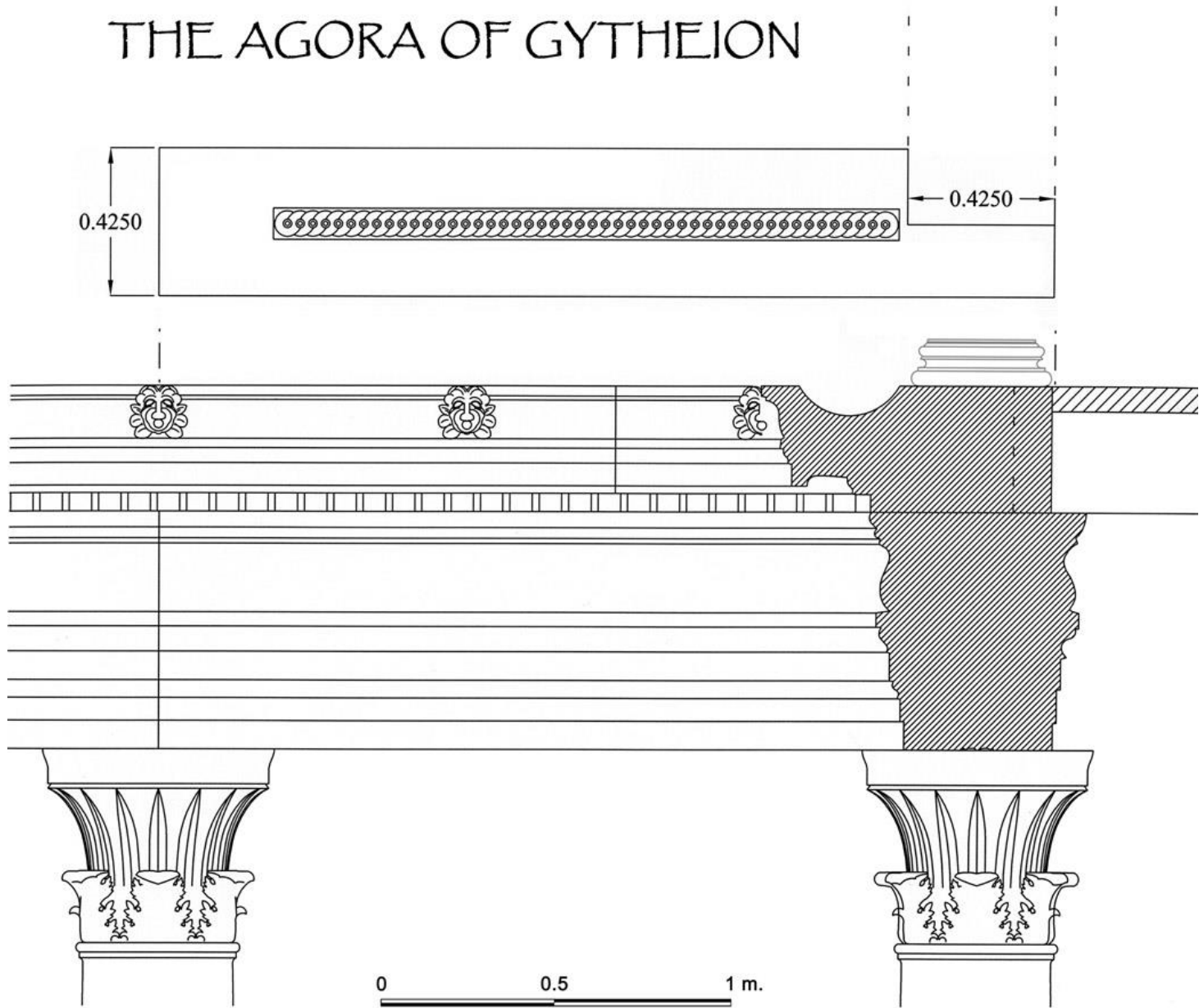













# Reims



