

THE ORIGINS OF THE
ORDERS AND
MONUMENTALIZAION

ATYPICAL TEMPLES

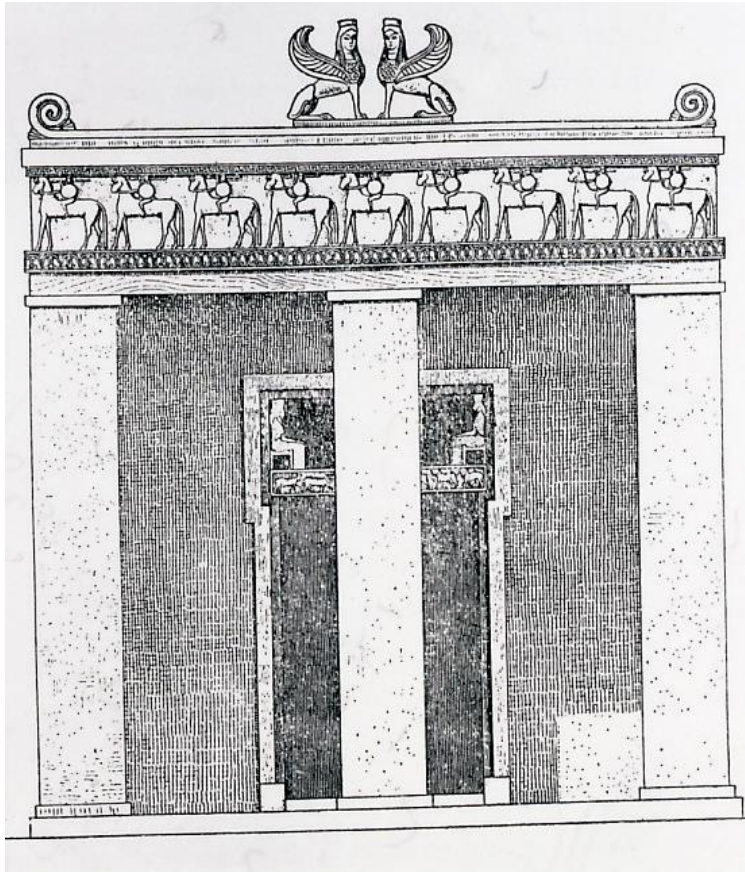

PRINIAS TEMPLE A



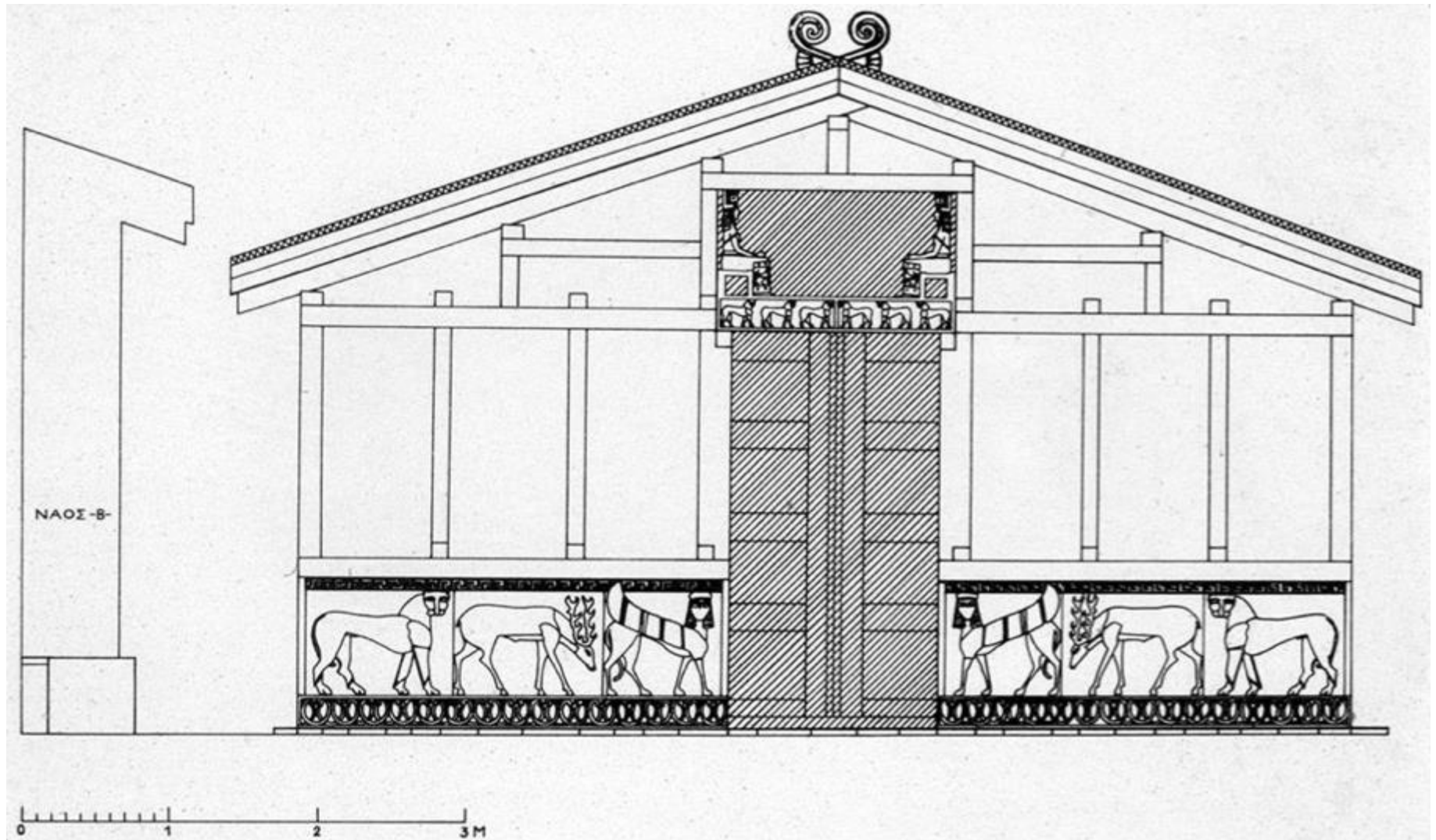

σχεδιαστική αναπαράσταση της πρόσοψης του ναού Α του Πρινιά



FOSSILIZATION PETRIFICATION



LEFKANDI (*Béotie*)

L'Hérôn du Xè.
Reconstitution

2

3

4

5

6

7

8

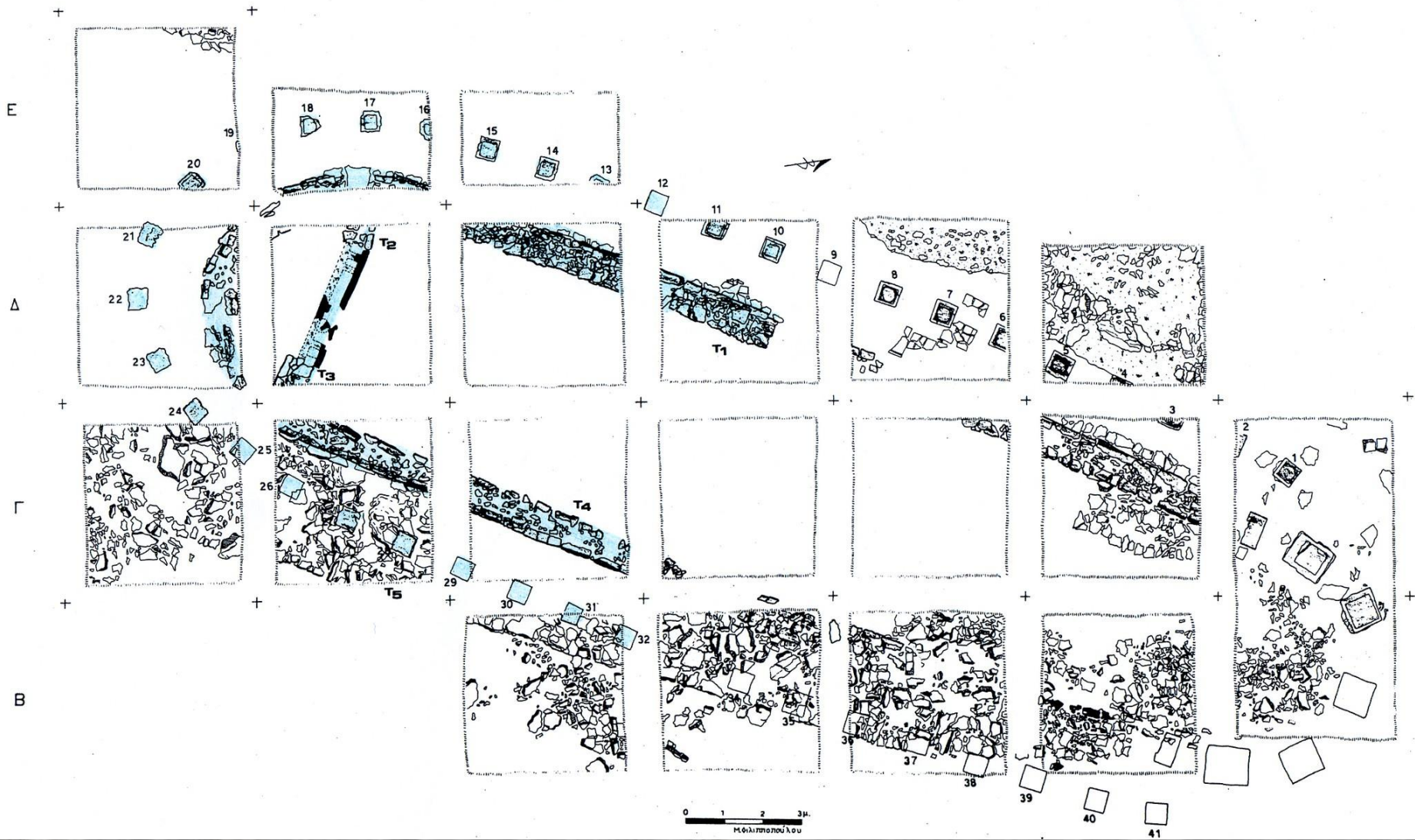

RAKITA, ACHAEA.





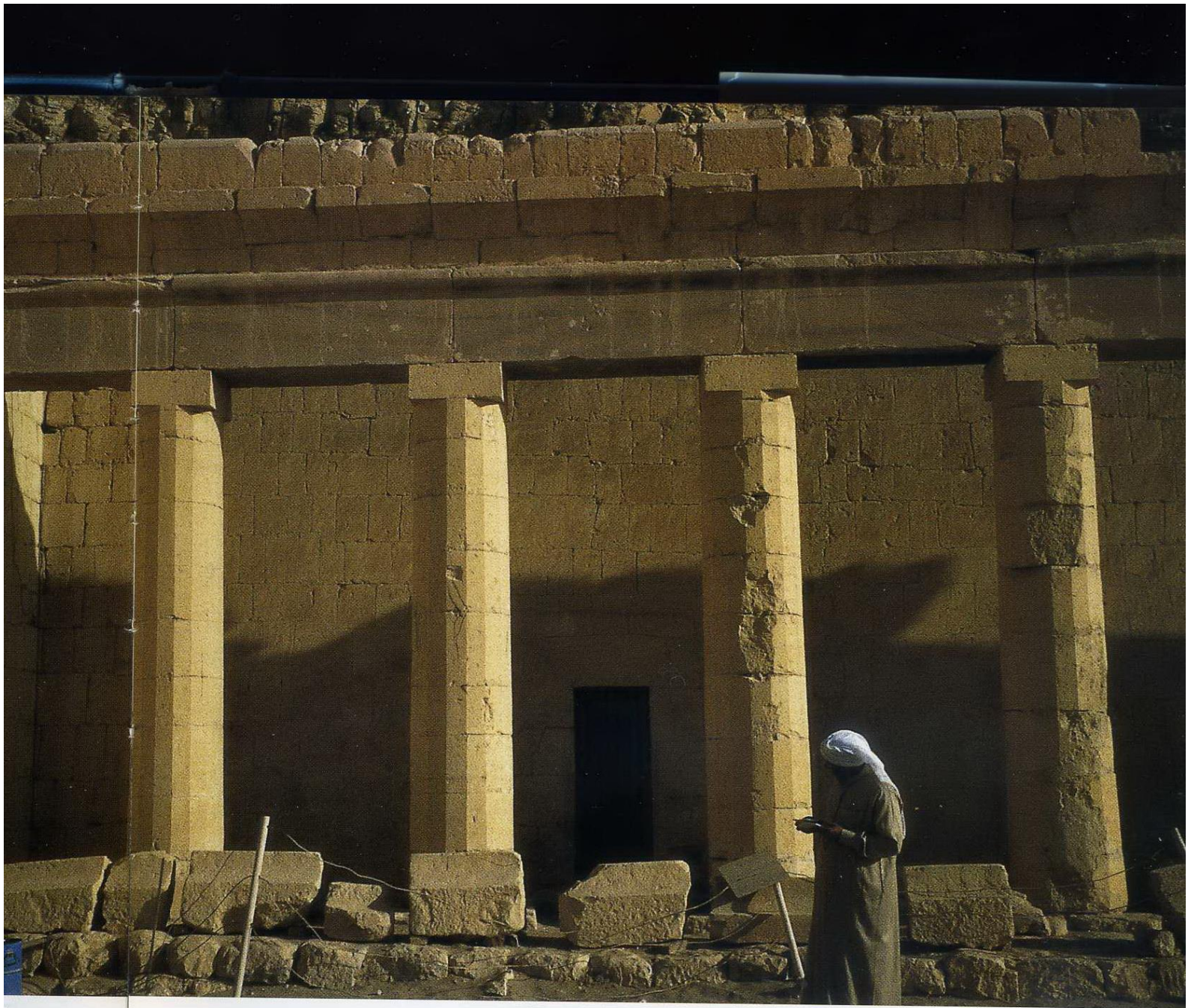

το ουσιώ-

στο σημαντικό μισό της Ολυμπίας (γύρω στο 600 π.Χ.)

της και συνεχιστής της αρχιτεκτονικής

είναι ο ναός της Αρτέμιδος

στον Παρθενώνα

στον Παρθενώνα

DEIR EL BAHAR, 1508–1458 П.Х.



BENI HASSAN





A photograph of a row of ancient Egyptian columns, likely from the Temple of Isis at Philae. The columns are made of light-colored stone and feature hieroglyphs. They are arranged in a perspective that recedes into the distance under a clear blue sky. The text is overlaid on the upper right portion of the image.

***VISITS TO EGYPT BY IONIAN
MERCHANTS**

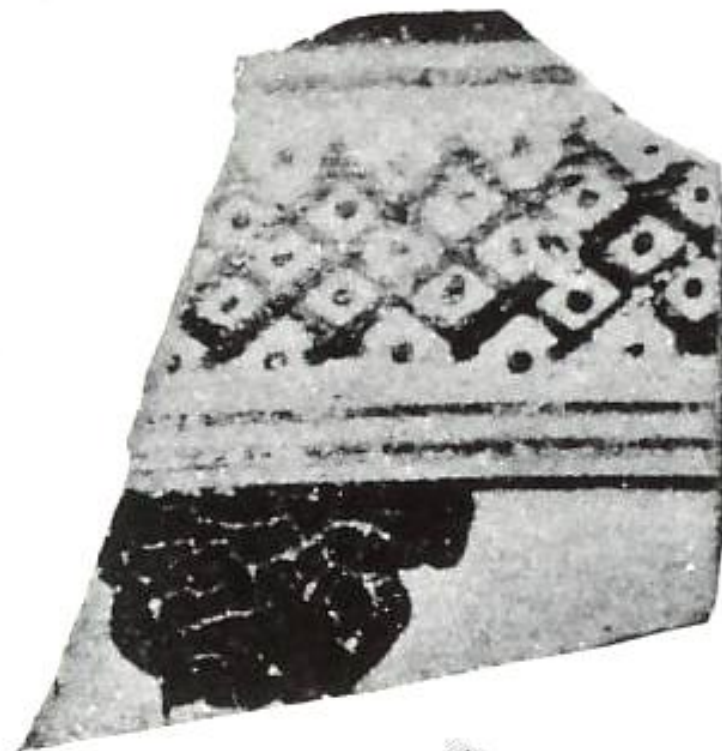

HERAION, PERACHORA,
MID 7TH C. BC

ΜΥΚΗΝΕΣ



η πύλη των λεόντων
(ΥΕ ΙΙΙ, πριν το 1200
π.Χ.)

MYCENE

TREASURY OF ATREAS

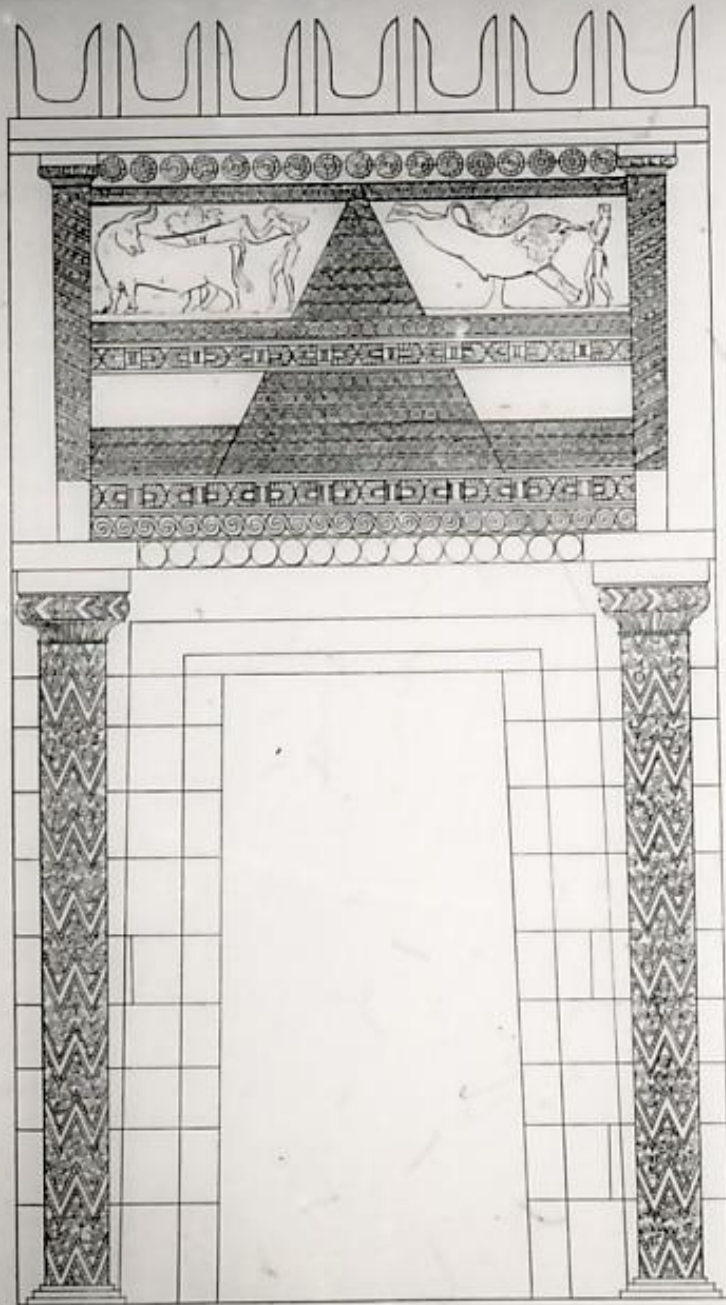







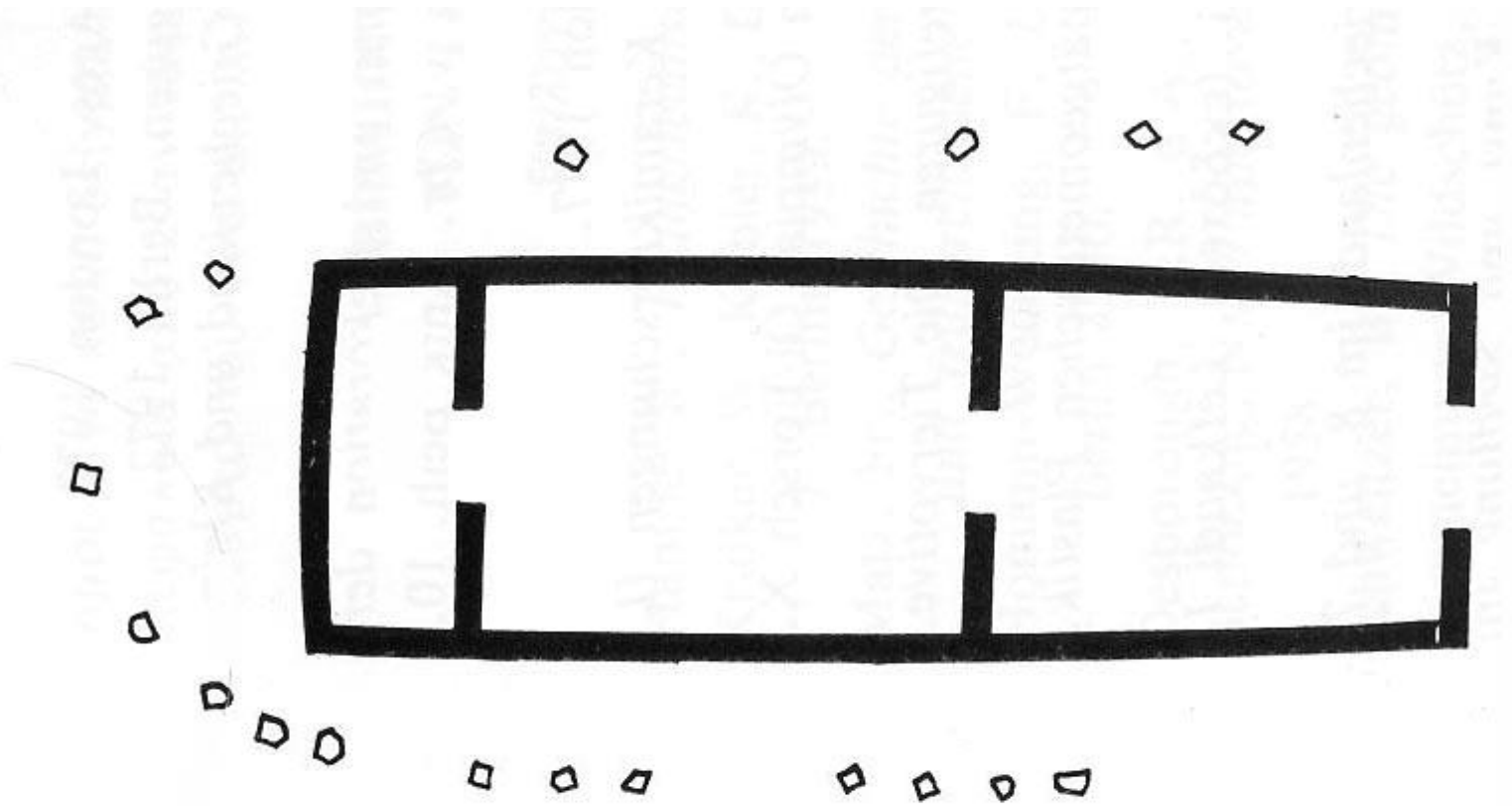

THERMON, AETOLIA, 10TH OR 8TH C. BC

IEPA



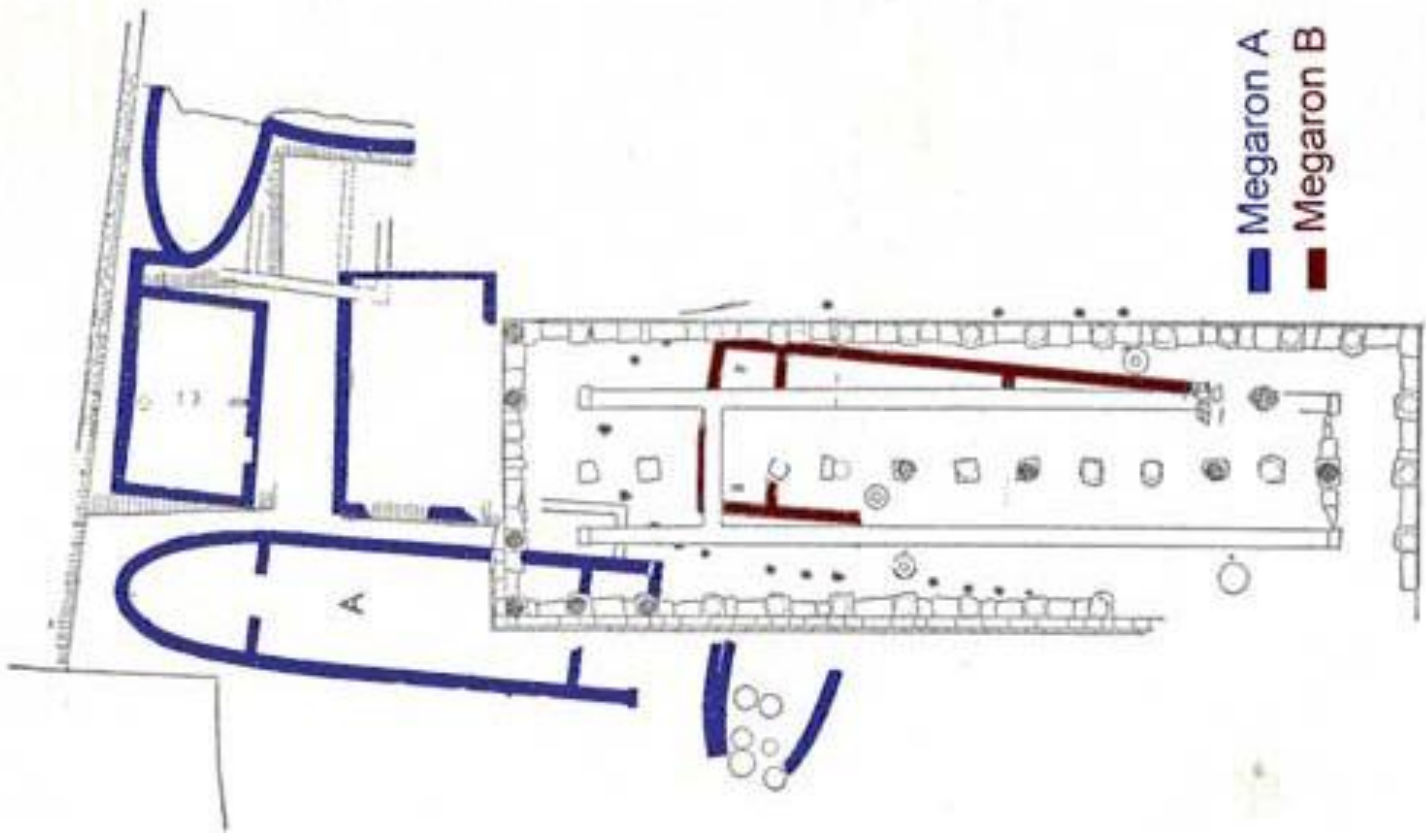

Megaron A

Megaron B

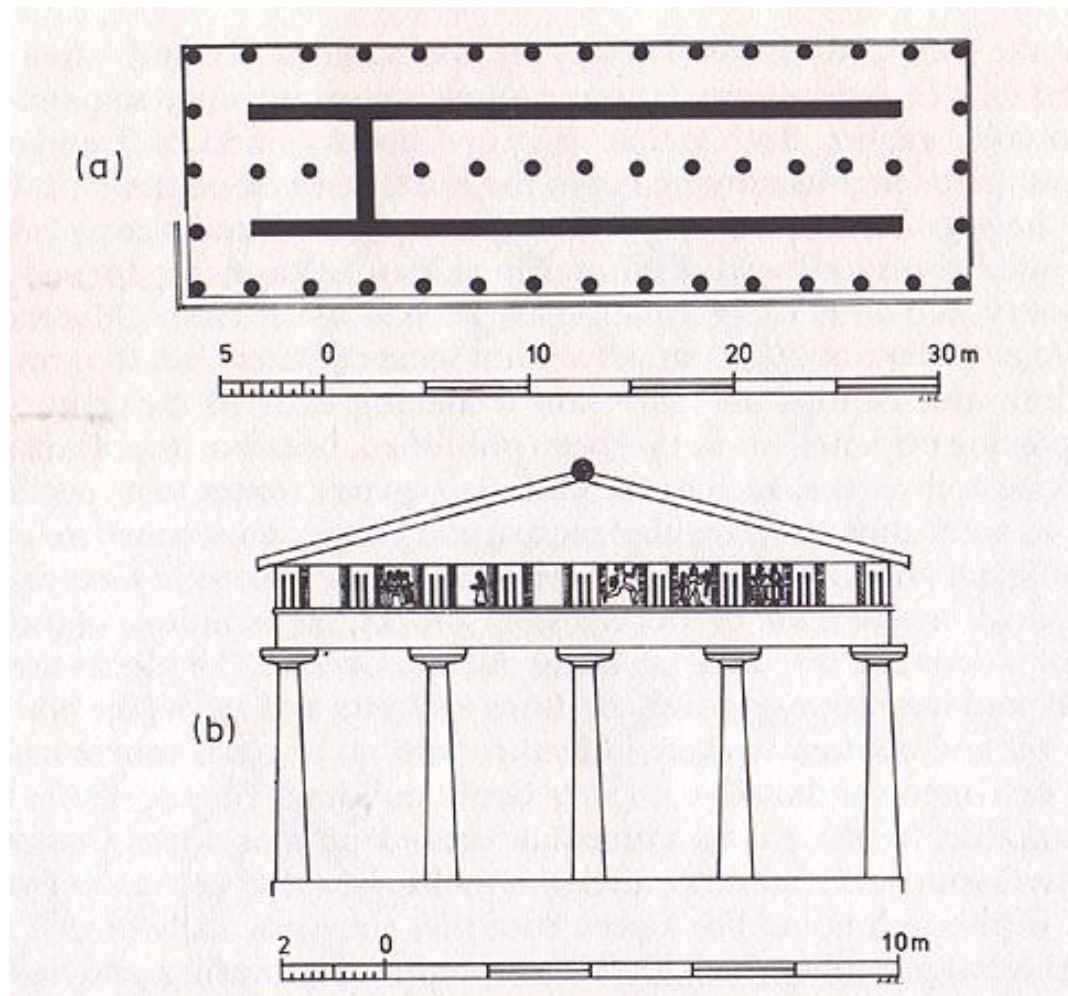

ΤΗΡΜΟΝ, ΑΙΤΟΛΙΑ. 625 π.Χ.

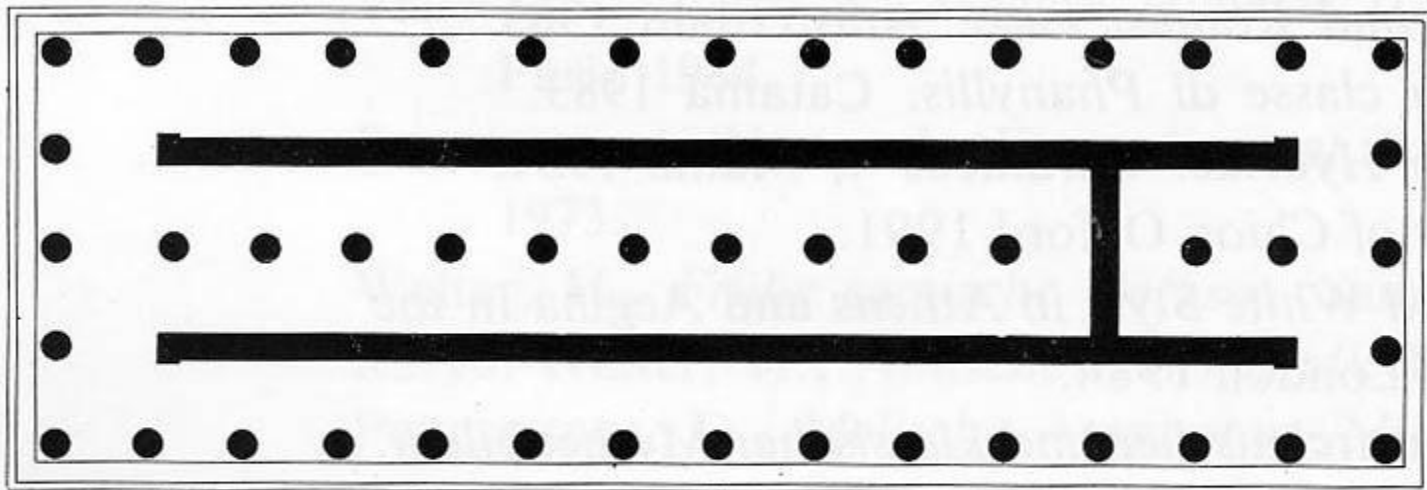



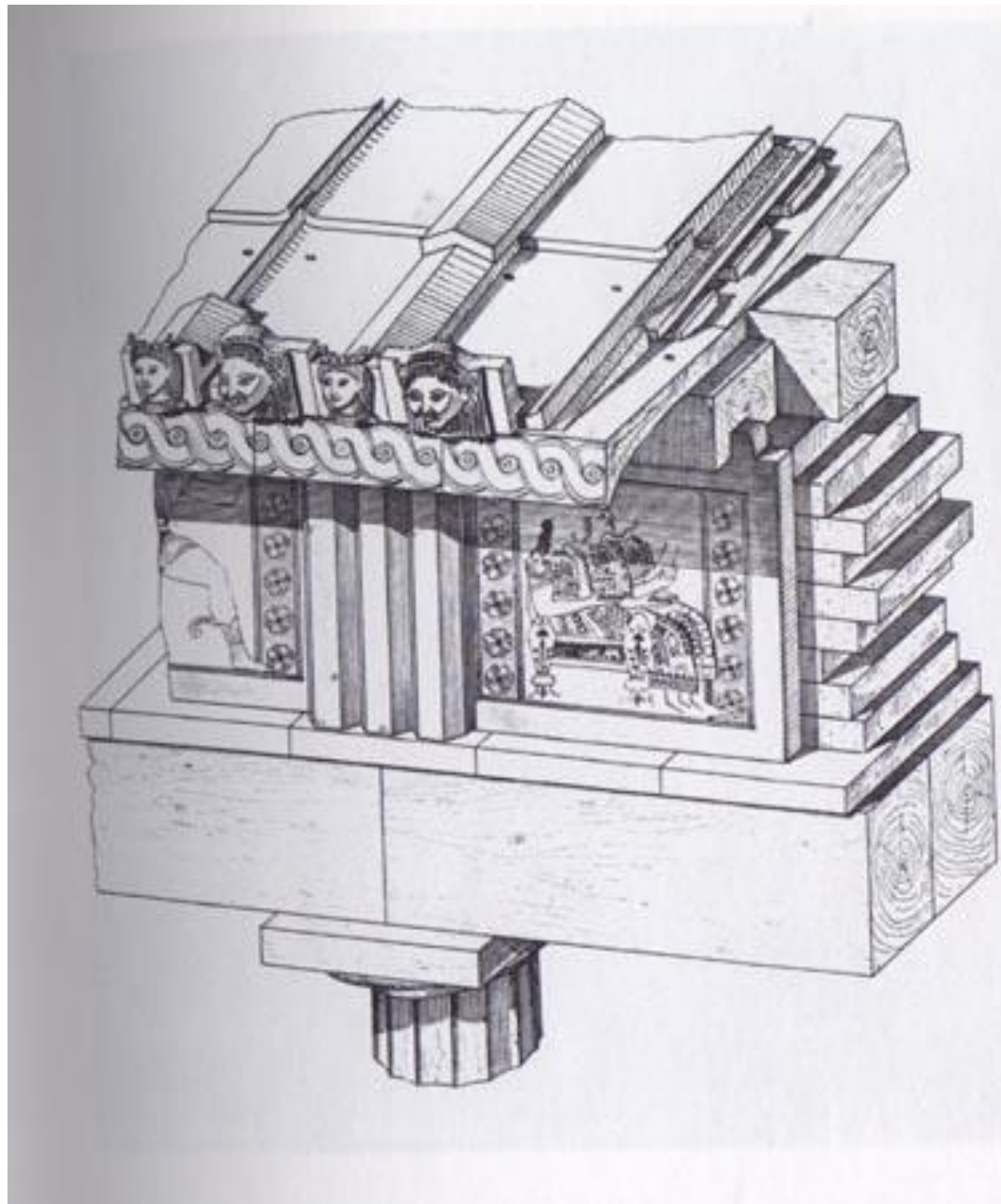

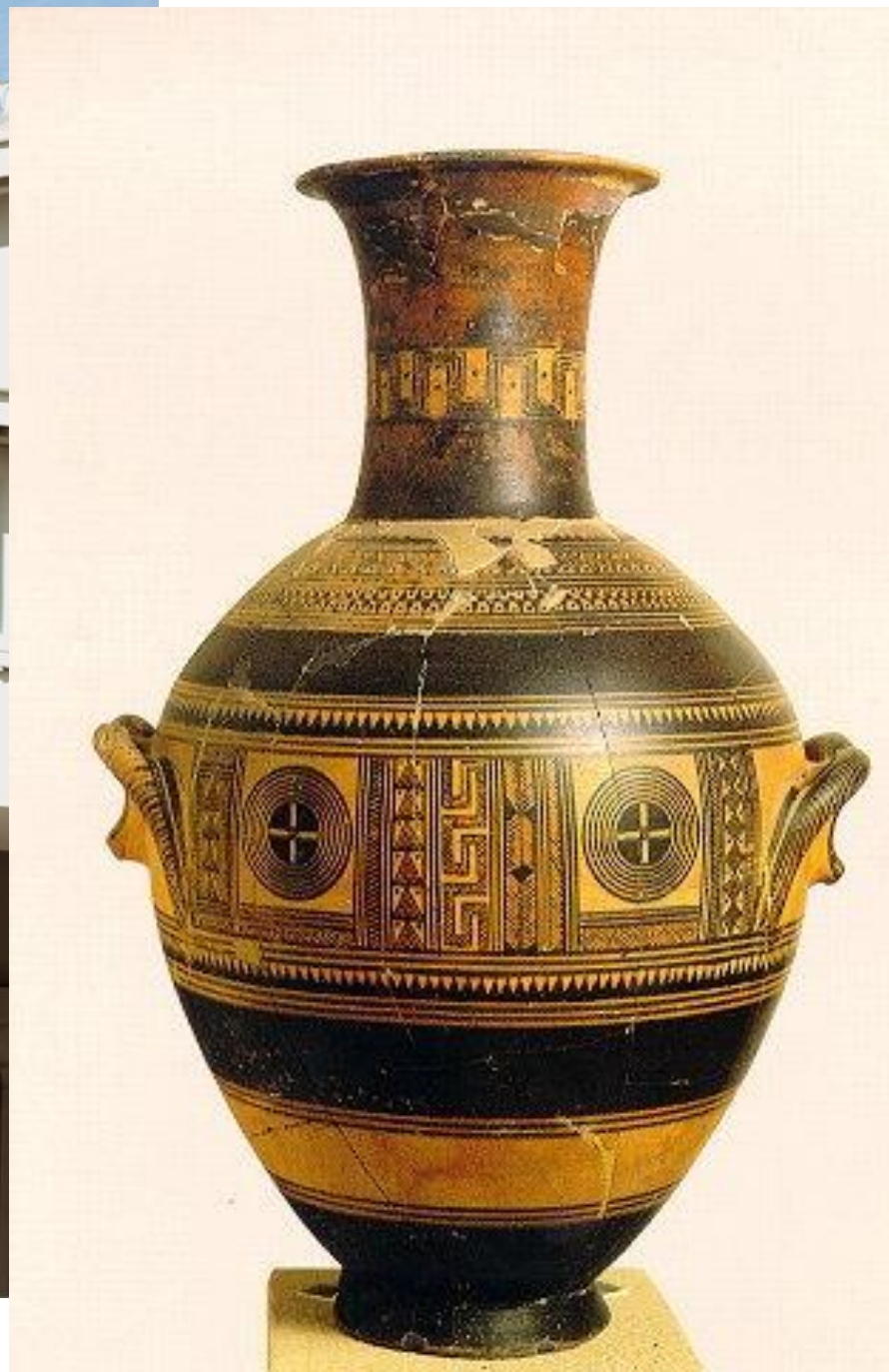

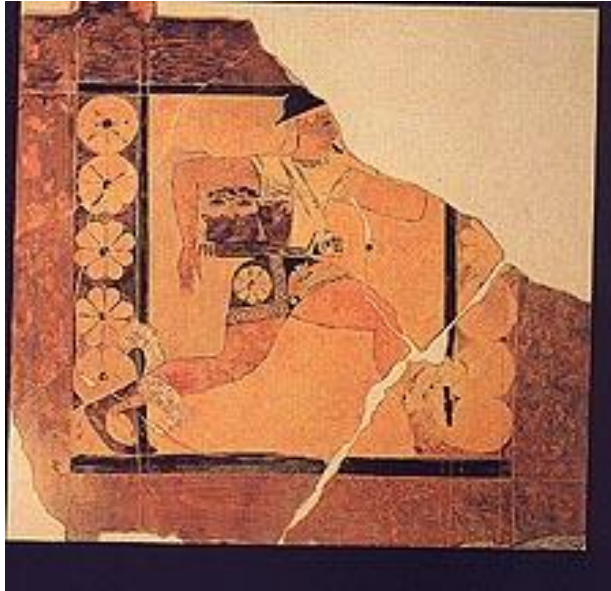



R. M. Cook , The Archetypal Doric Temple, *ABSA* 65 (1970)

“Certainly there was little time for evolution.....”.

“ὄρα δέ γ’ εἴσω τριγλύφων ὅποι κενὸν δέμας
καθεῖναι.” *Ιφιγένεια εν Ταύροις.*

Μετ-όπαι. Vitruvius*

See if we can descend between the triglyphs

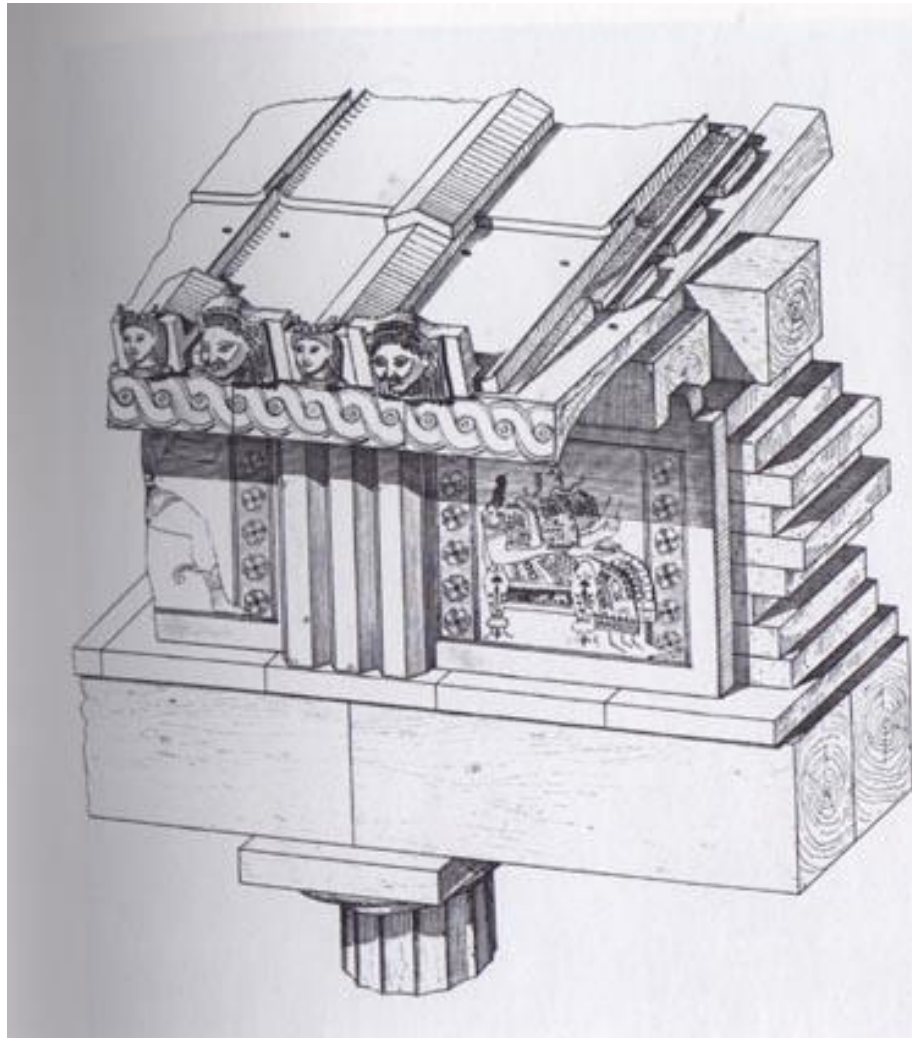

E. KOHLMAYER, HITTITE TEMPLE OF THE STORM GOD, *NEA* 72, 2009. 190-202

TRIGLYPHS =
WINDOWS

FOSSILIZED
WINDOWS IN
HETTITE
ARHCITECTURE



The Hittite period renovations to the temple included replacing the plain orthostats with new ones carved in the form of false windows and bull-men. Bull-men are common in Hittite art. The false windows may have been in imitation of the windows typical of Hittite temple construction, but which would have been difficult to install in the pre-existing temple in reality.

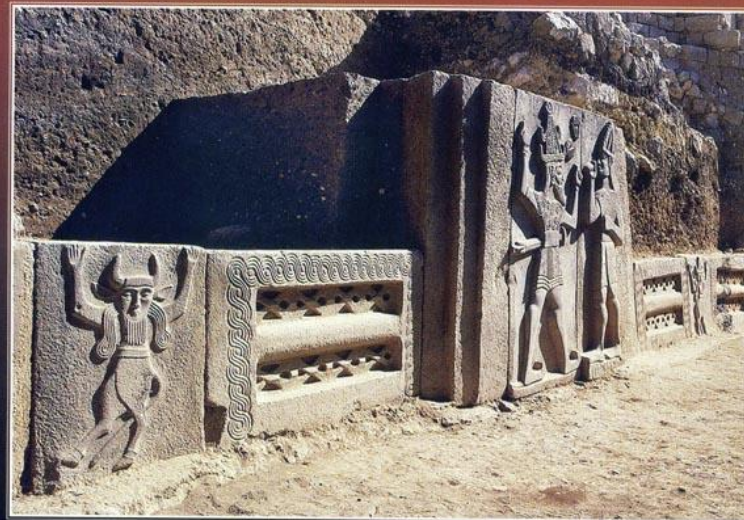

The Storm God himself is depicted facing King Taita on the eastern wall. The relief may have served as the cult image, and indicates that the temple's orientation shifted in the Hittite period so that the east (rather than the north) wall was the focal point.

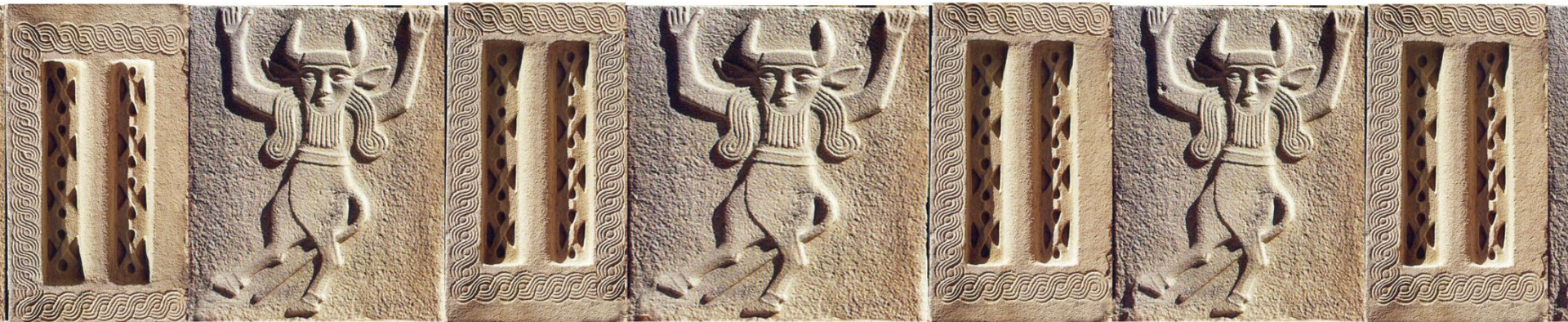

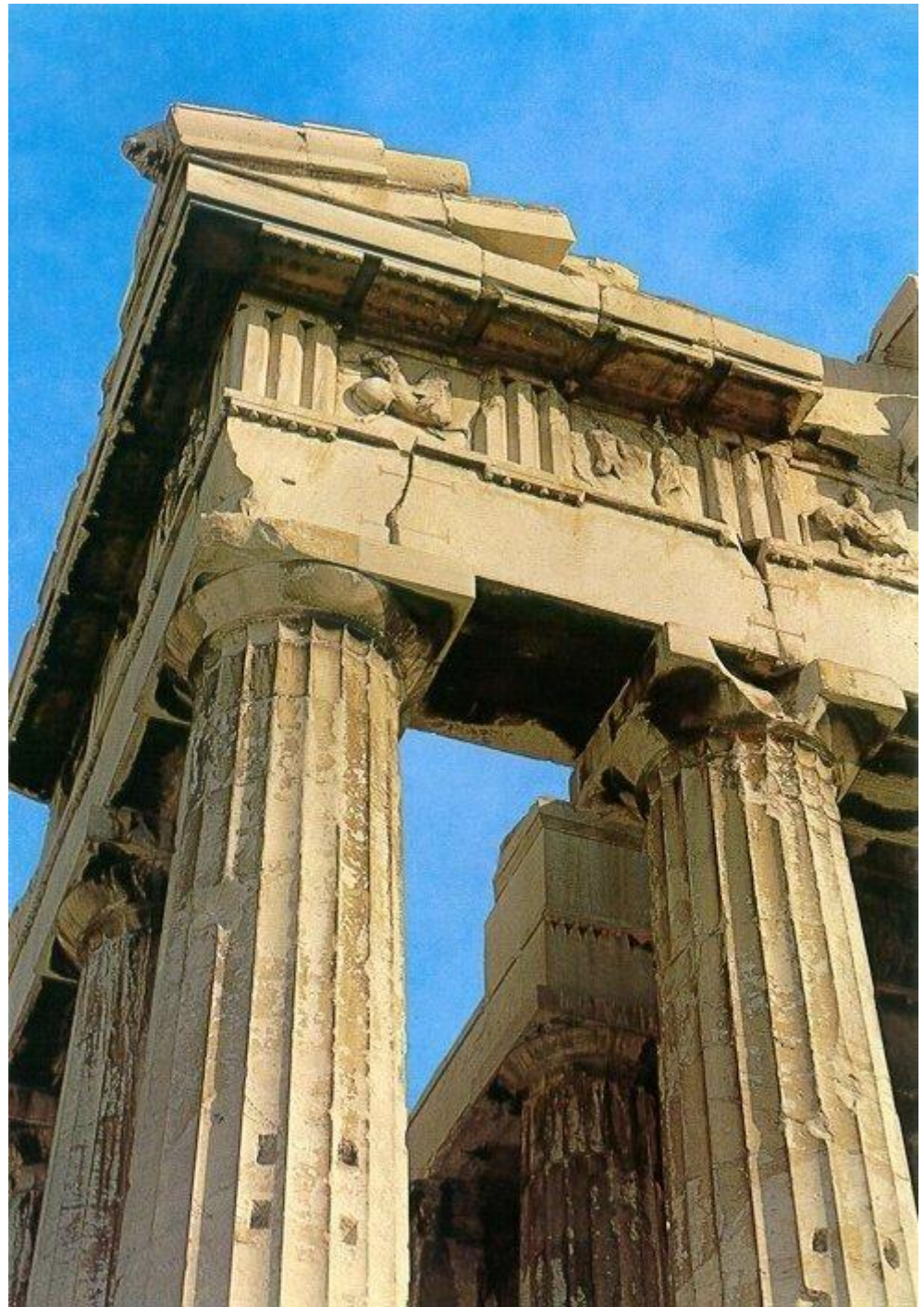

WINDOWS IN
THE CORNERS?

MYCENAEAN TRIGLYPH FRIEZE

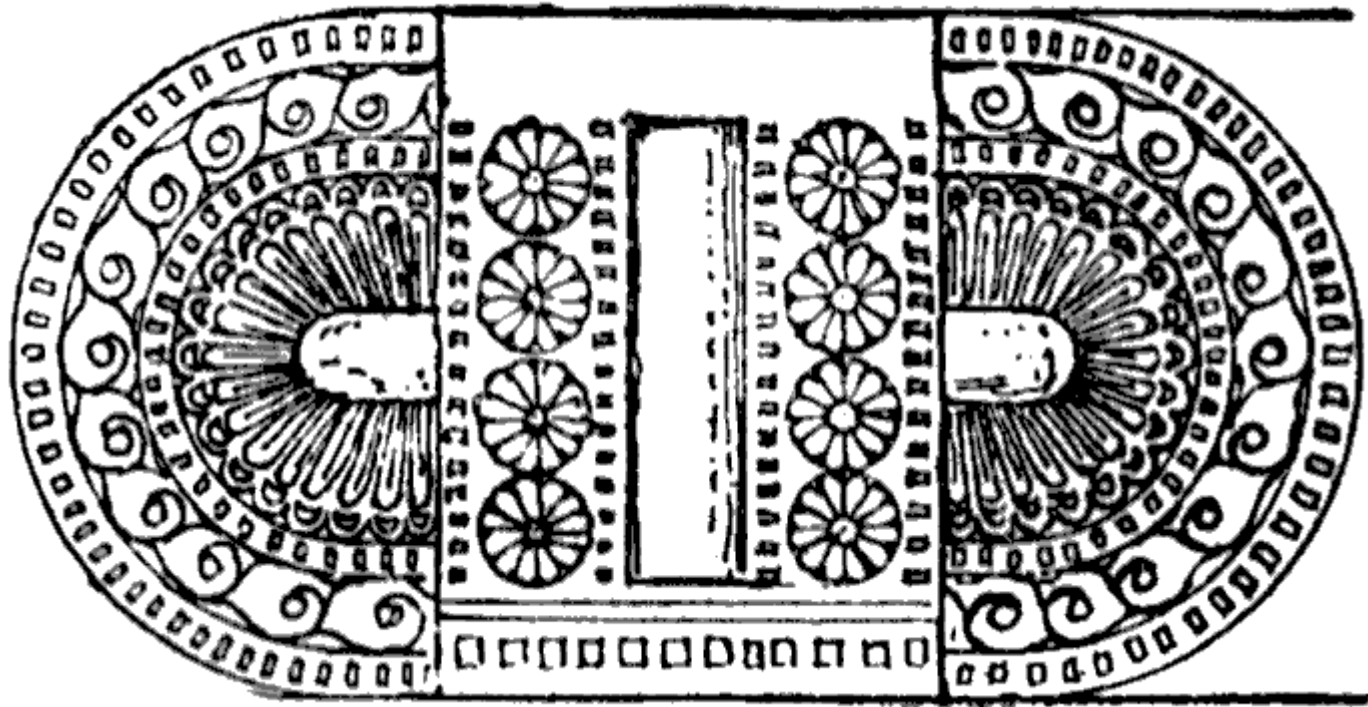

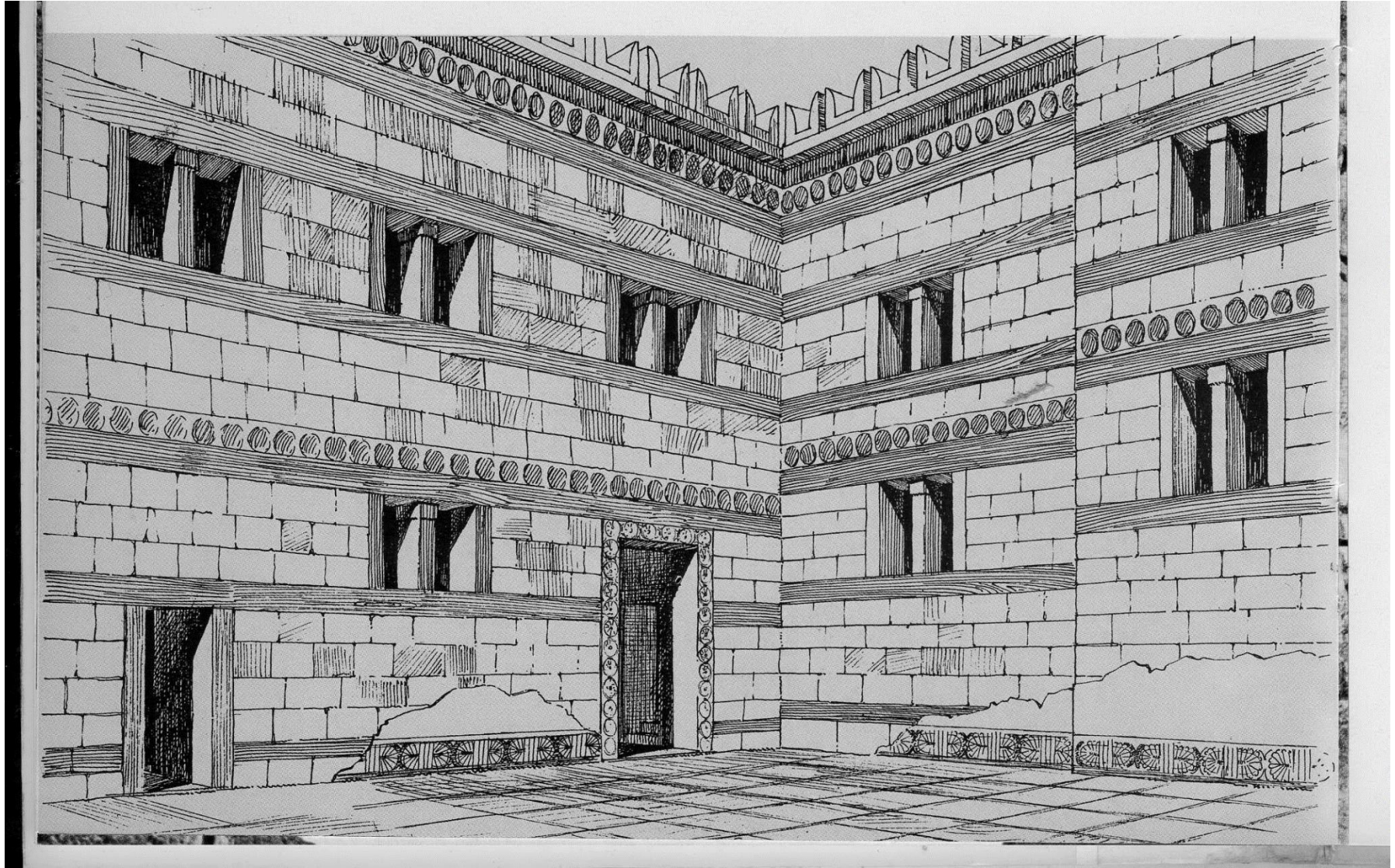



1. TRIGLYPH FRIEZE WAS FULLY DEVELOPPED IN WOOD

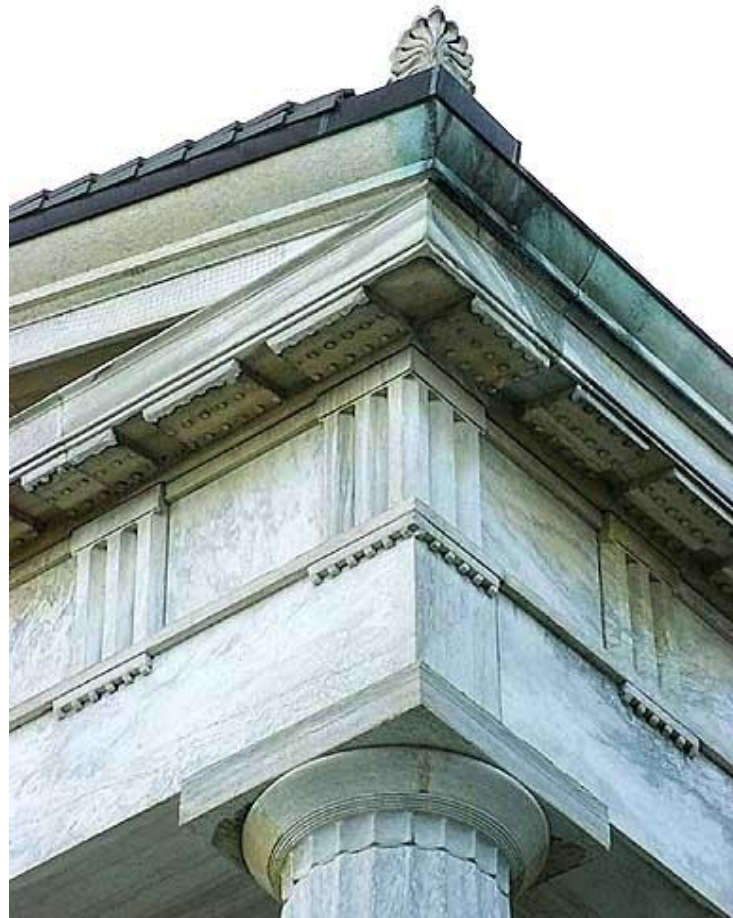

2. THE ORDER WAS STANDARDIZED DURING
THE PROCESS OF FOSSILIZATION.
THE WOODEN PROTOTYPES HAD A VARIETY
OF FEATURES, WITHOUT CONSISTENCY OR
RHYTHM



A VARIETY OF ORDERS SEEN IN HUMBLER, DOMESTIC STRUCTURES



PRODUCTS OF PAINTERS' IMAGINATION?

Sobocinski, M. G. (forthcoming) "Visualizing Architecture Then and Now: Mimesis and the Capitoline Temple of Jupiter Optimus Maximus," in *A Companion to Roman Architecture*, edited by Roger Ulrich and Caroline Quenemoen. Wiley-Blackwell.









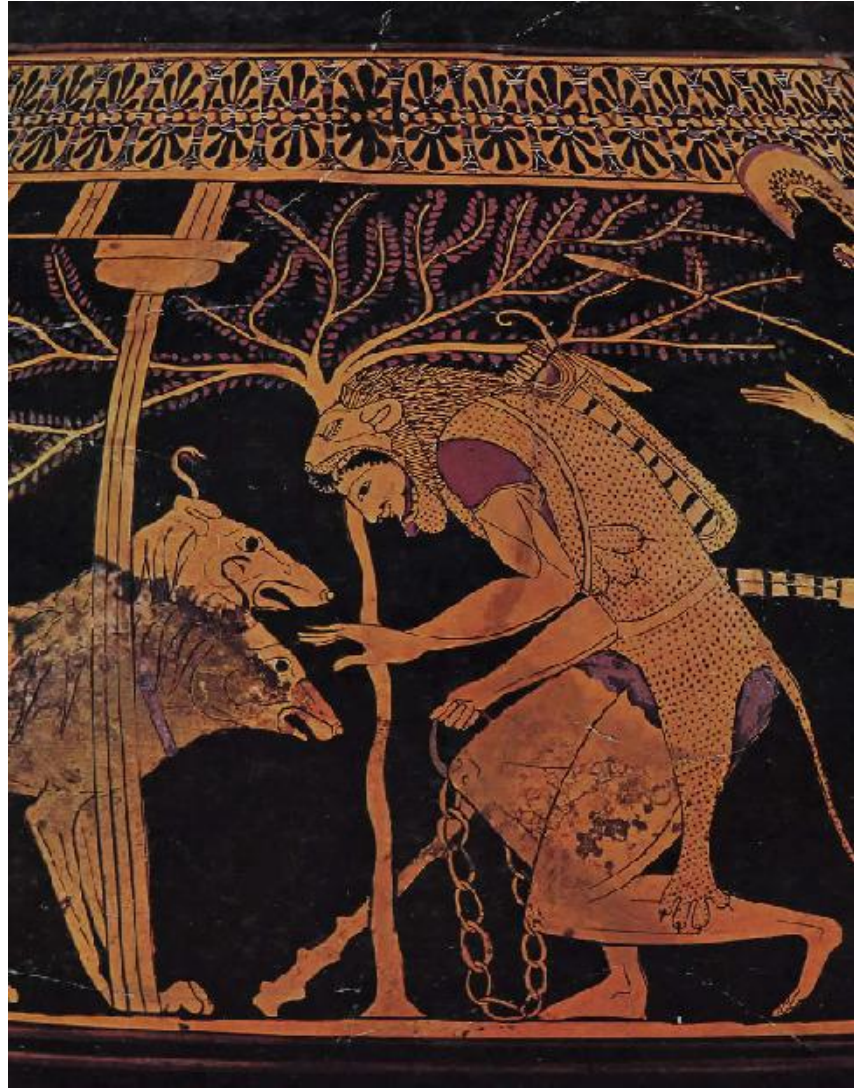

IONIC BRACKET OR A DORIC CAPITAL IN TWO DIMENSIONS???





WOODWORKS WITH LARGE SECTIONS IN BHUTAN









© shunya.net



- A *WOODEN* DOOR MADE OF MARBLE.
- VERGINA, PHILIPP'S TOMB

Wilson Jones, M., 2002. Tripods, *Triglyphs*, and the *Origin* of the Doric Frieze. *American Journal of Archaeology*, 106 (3), pp. 353-390



FLUTES ON TREE TRUNKS



www.shutterstock.com · 36375079

PEELING A WOODEN TRUNK RESULTS IN FLUTING
THE SHAFT

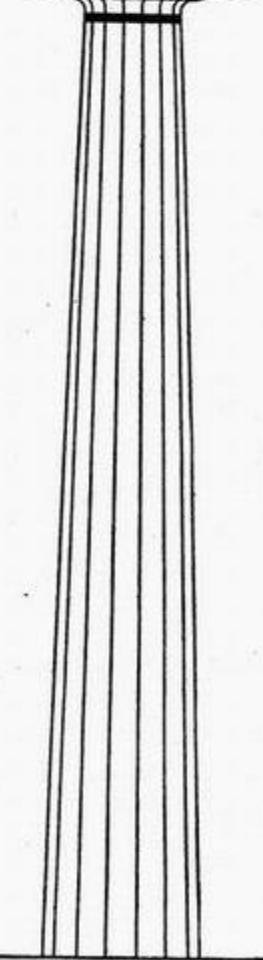
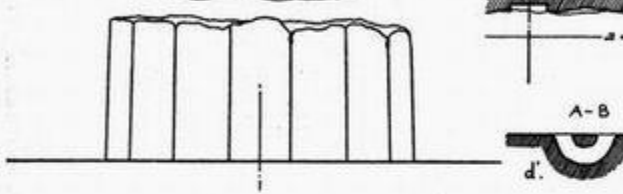

(b)

Figure 26. (a) Pronaia, Delphi, *Temples de Delphes*, 3: *Le Sanctuaire*, Boccard, 1927; permission of the École Française de Rome. (b) Column of the Pronaia at Delphi, from *Architectural History of Greece*, (Cambridge University Press, 1974); permission of Cambridge University Press.



www.shutterstock.com · 36375079



TRANSLATION FROM WOOD TO SOFT STONES



THICKER FEATURES



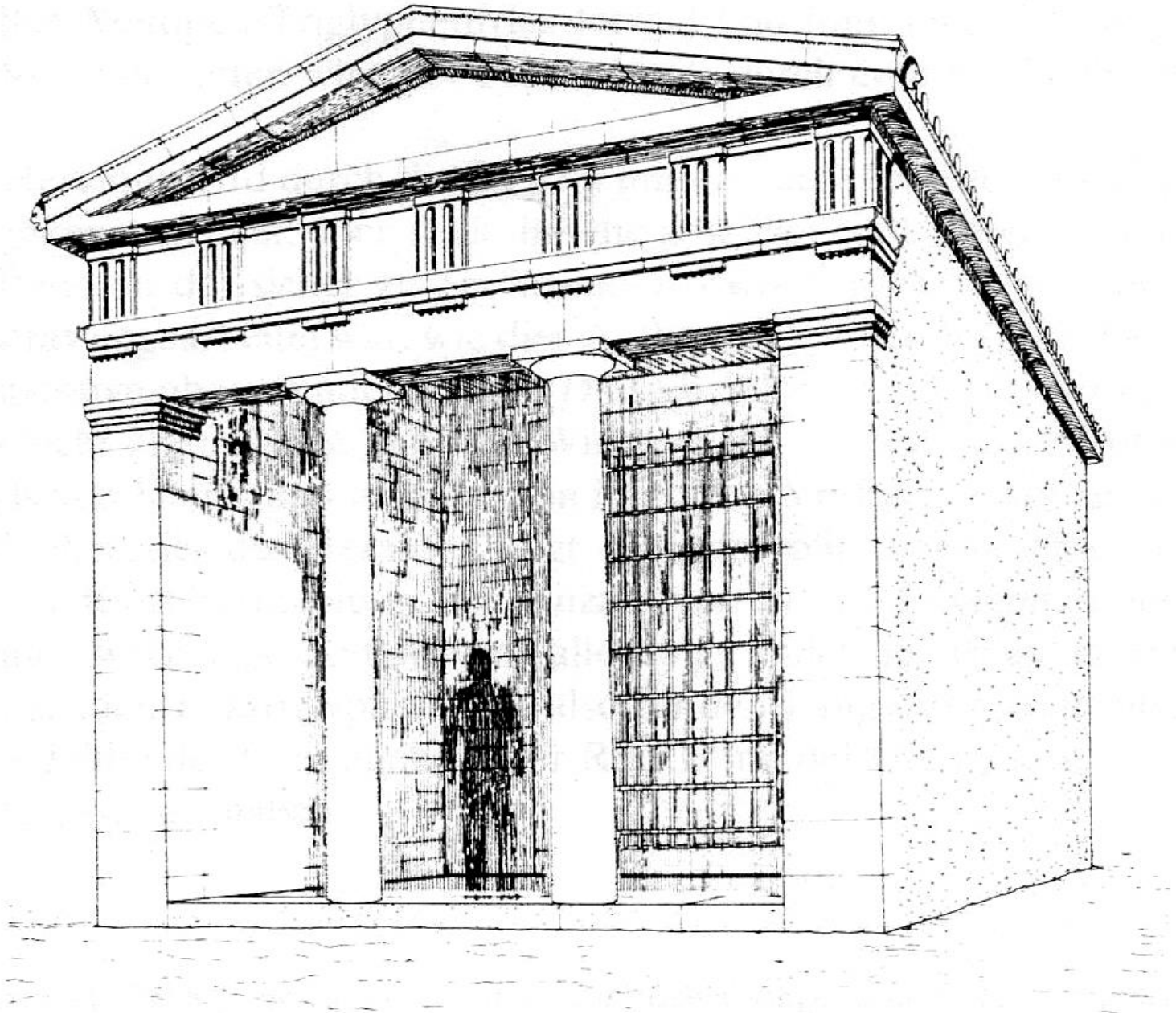



Copyright © Janice Siegel 1998

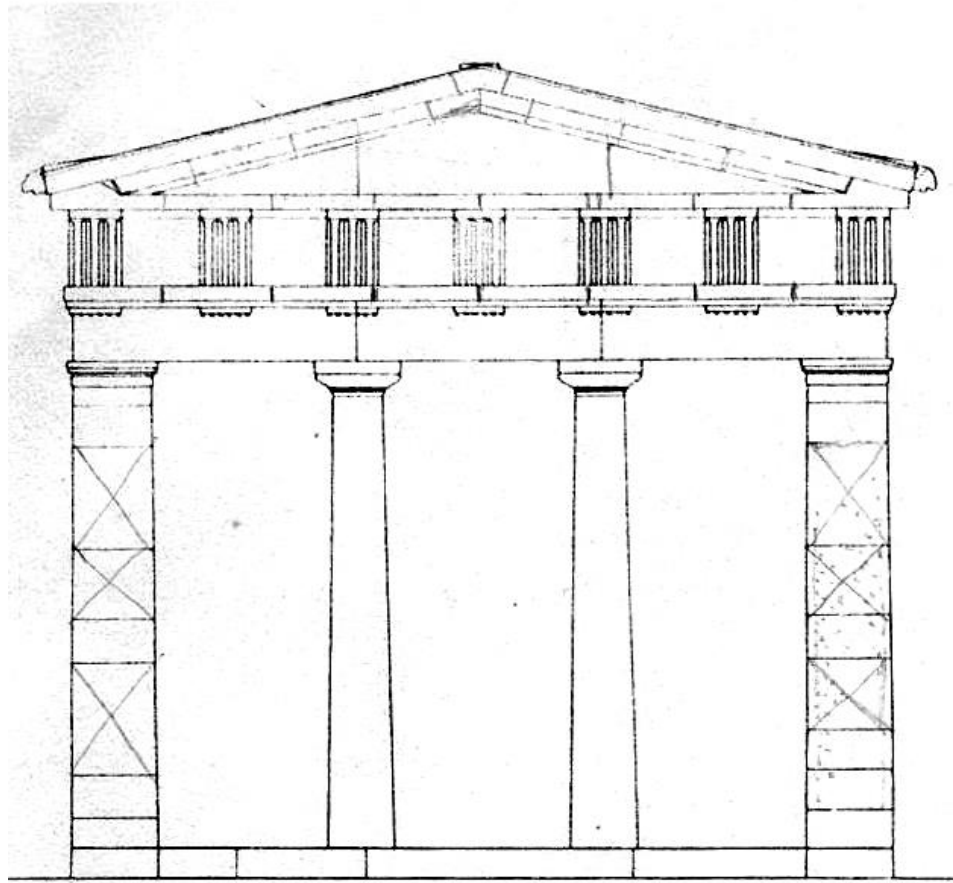

DELOS

Heraion

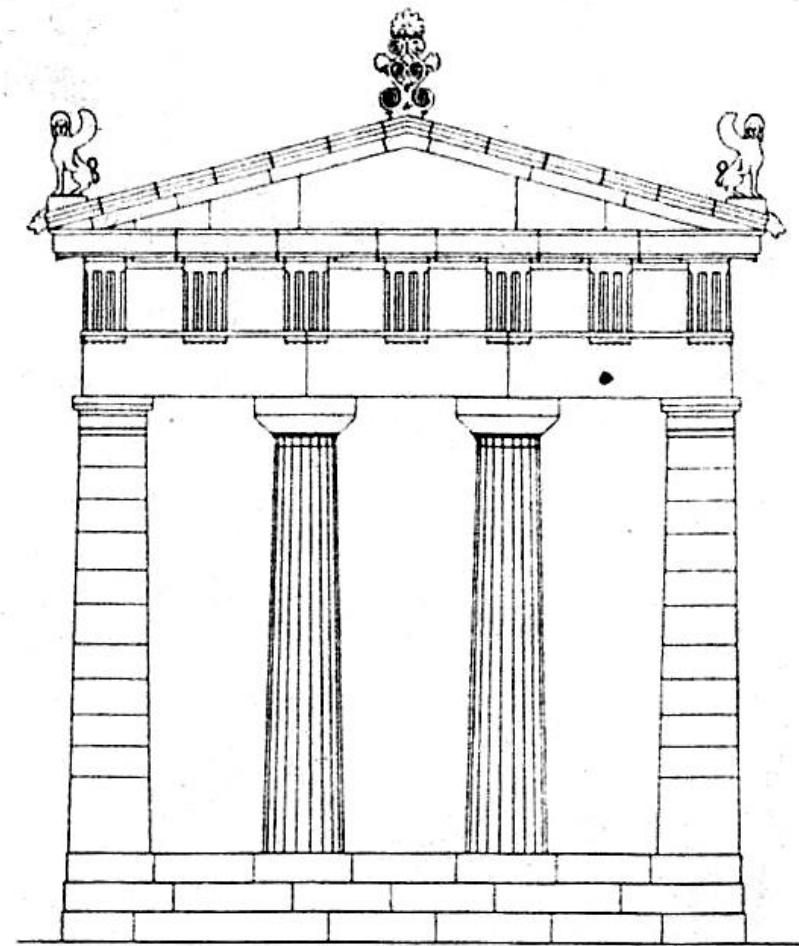

PAROS

Artemis-Tempel



Abb. 2. Front des Heraions von Delos und des Artemis-Tempels von Paros. M. 1 : 125





0 2m.

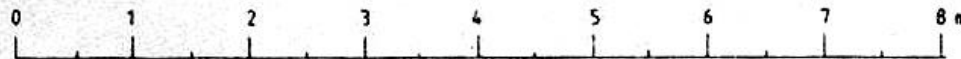
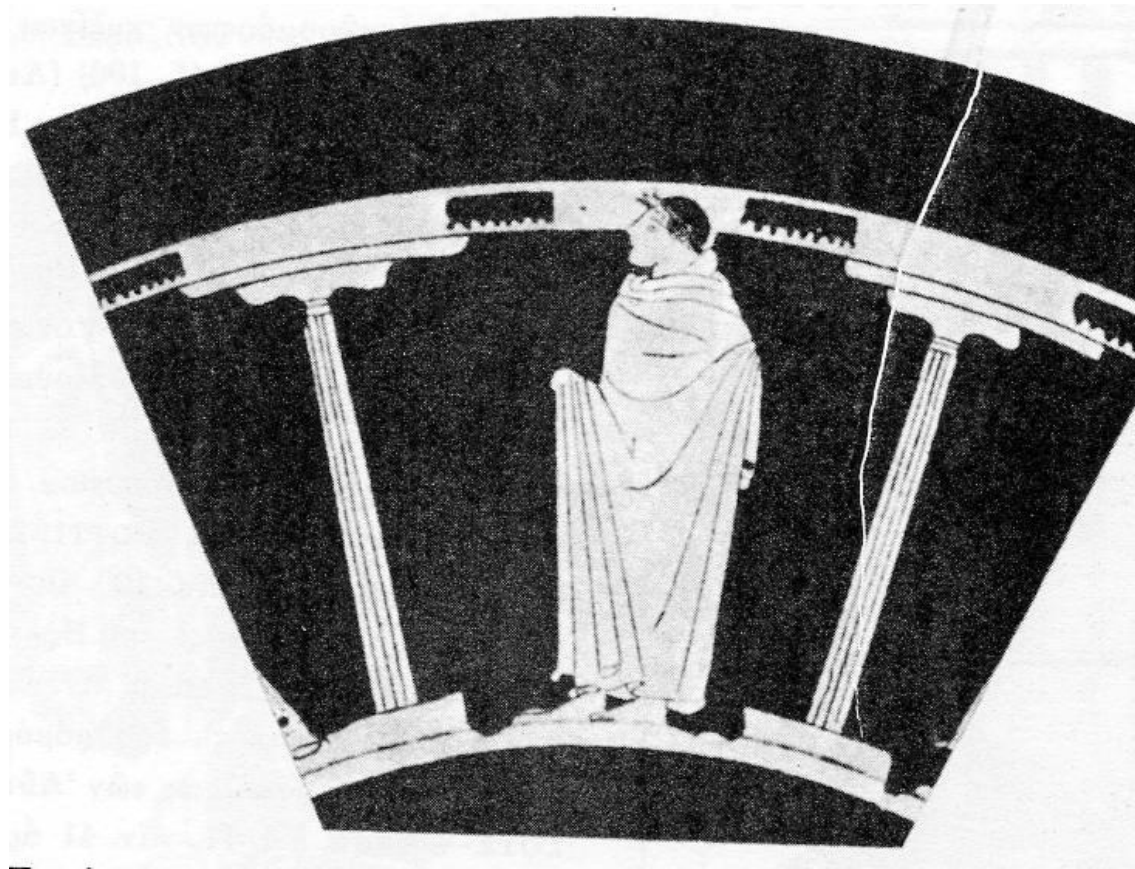
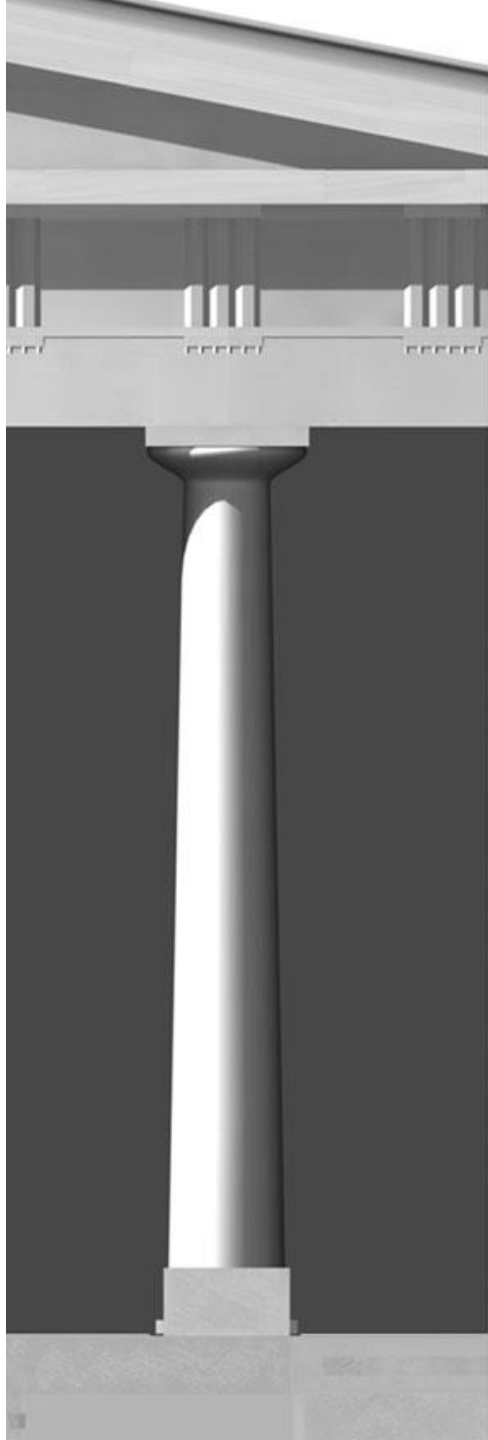
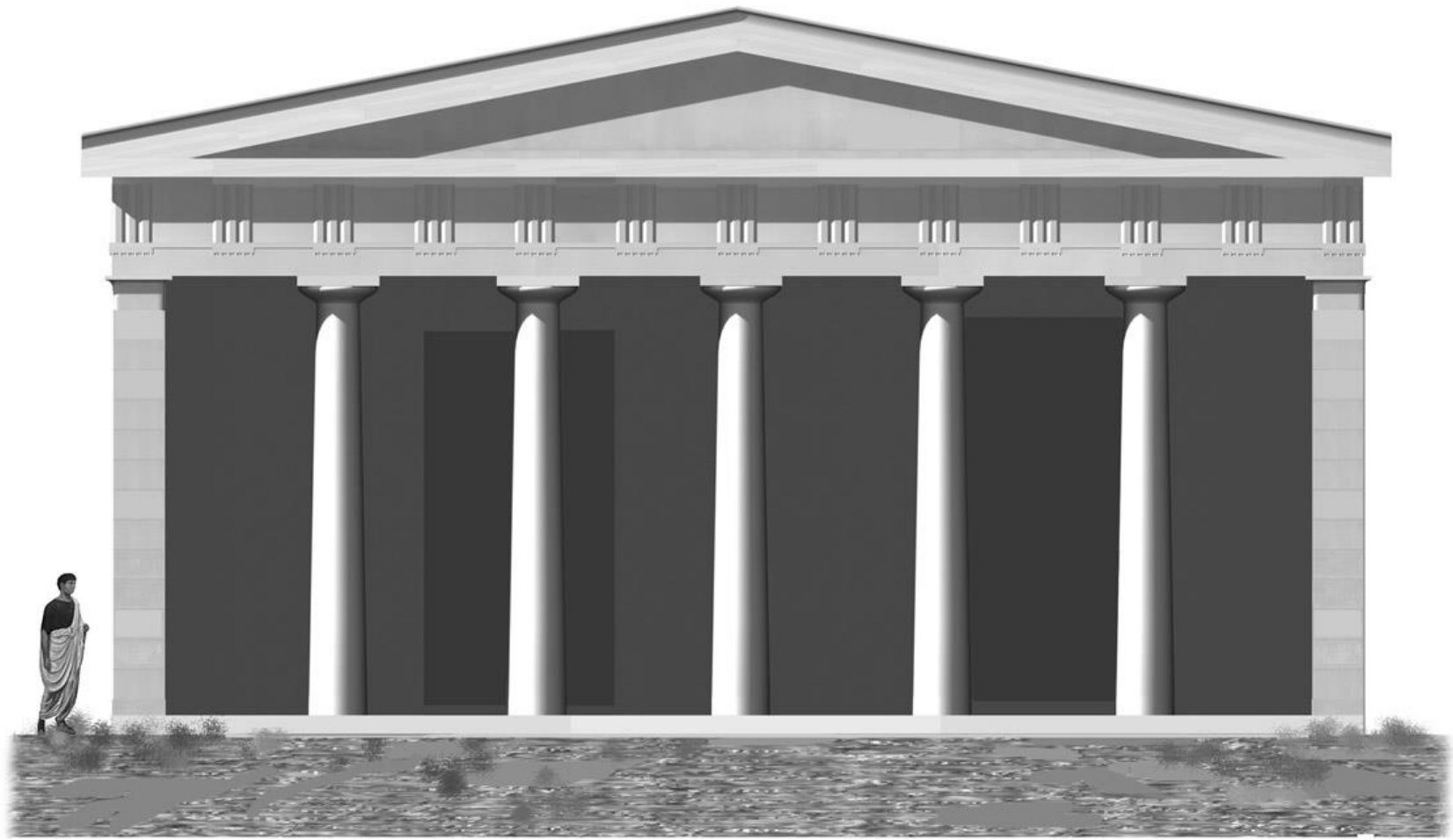





ΝΑΟΣ «ΤΗΣ ΔΗΜΗΤΡΑΣ» ΣΤΟ ΣΑΓΚΡΙ (ΓΥΡΟΥΛΑΣ)
ΝΑΕΟΥ (540-530 π.Χ).

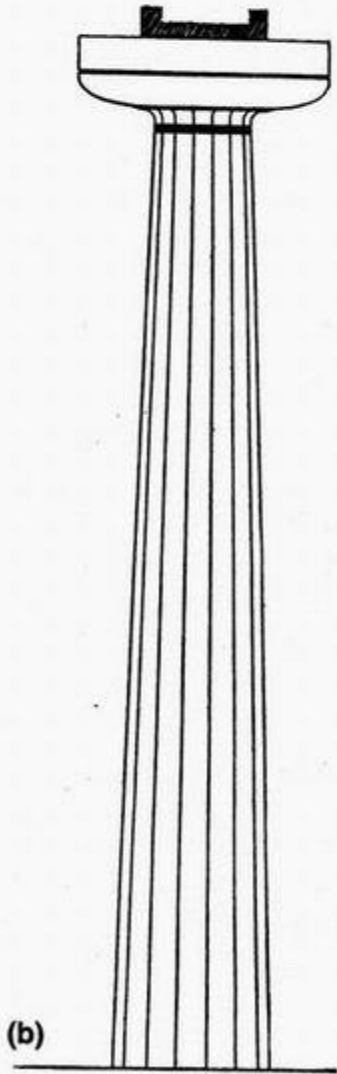
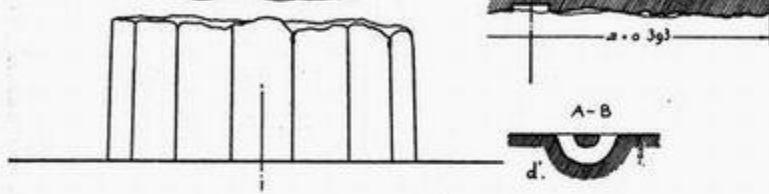

Figure 26. (a) Capital of the Temple of Athena Pronaia, Delphi, from R. Demangel, *Les Temples de tuf, FdD II: Topographie et Architecture, 3: Le Sanctuaire d'Athéna Pronaia 1* (Paris: de Boccard, 1923) pl. 13, reproduced by permission of the French School in Athens (École Française d'Athènes), (b) Reconstructed column of the Temple of Athena Pronaia, Delphi, from D.S. Robertson, *Greek and Roman Architecture*, (London: Cambridge University Press, 1974) 65, fig. 25, reprinted with the permission of Cambridge University Press.

ENTASIS











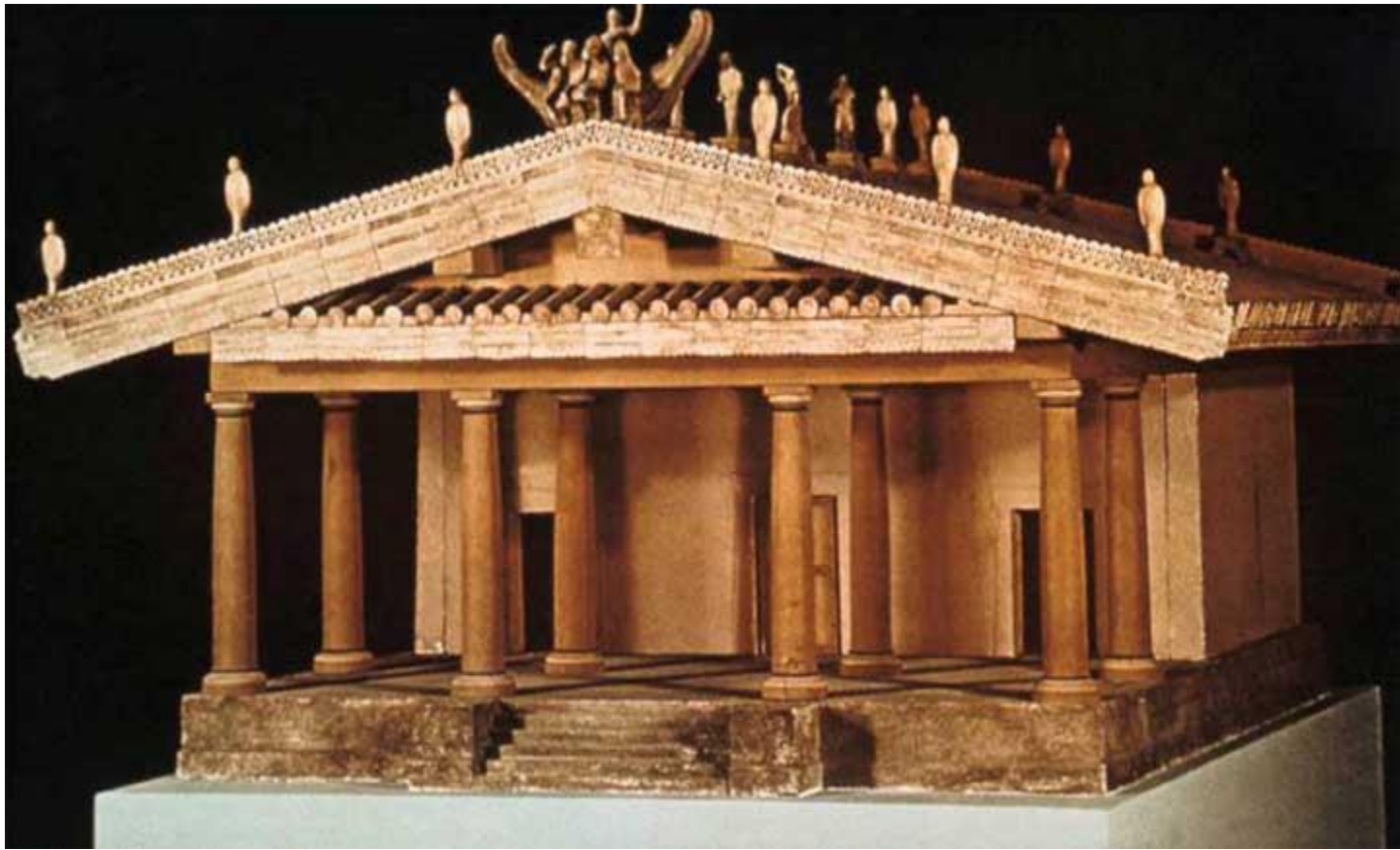







THE PEDIMENT. EMBLEM OF RELIGIOUS ARCHITECTURE



πήλινος υστερογεωμετρικός οικίσκος από
το Ηραίο της Περαχώρας
(μέσα 8^{ου} αι. π.Χ.)

23/11/2021



πήλινος αναθηματικός οικίσκος από
το Ηραίο του Άργους (τέλη
8ου αι. π.Χ.)

77

πήλινος αναθηματικός
οικίσκος από το Ηραίο
του Άργους (τέλος
8ου αι. π.Χ.)

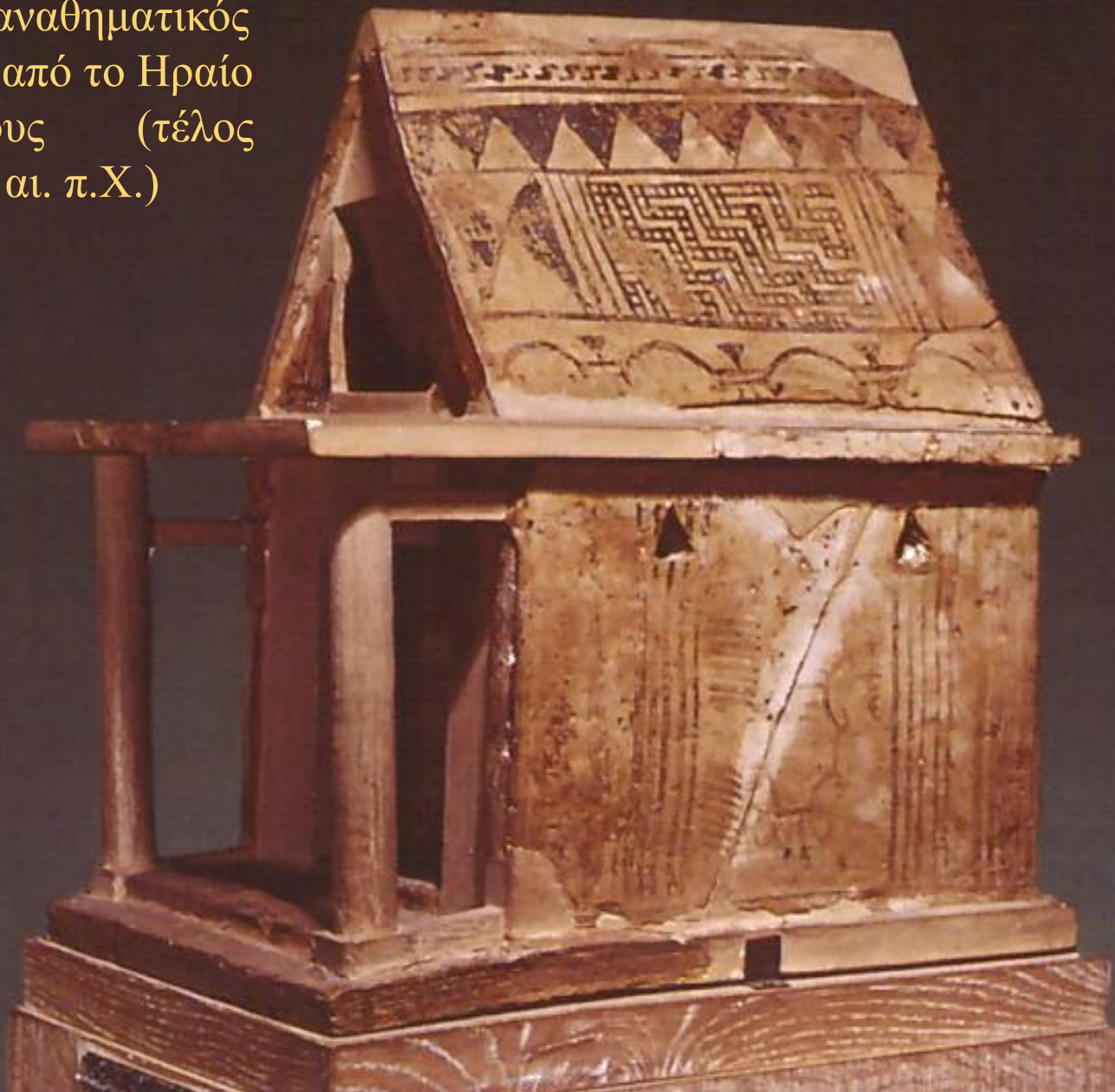

ΟΜΟΙΩΜΑΤΑ ΟΙΚΙΩΝ

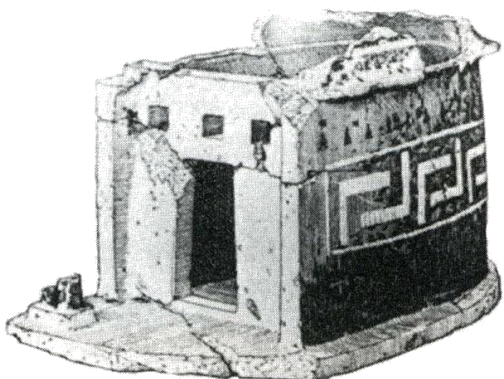

πήλινος αναθηματικός οικίσκος
από το Ηραίο της Περαχώρας
(μέσα 8^{ου} αι. π.Χ.)

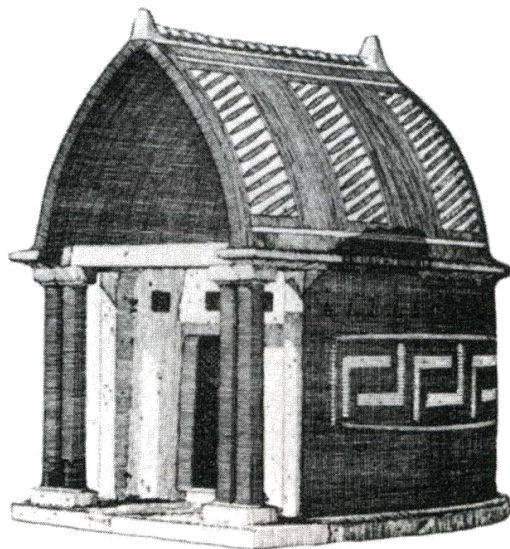

πήλινος αναθηματικός οικίσκος
από το Ηραίο του Άργους
(τέλος 8ου αι. π.Χ.)





smooth side

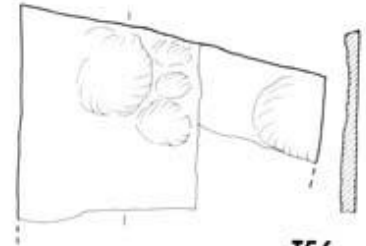

T56



smooth side

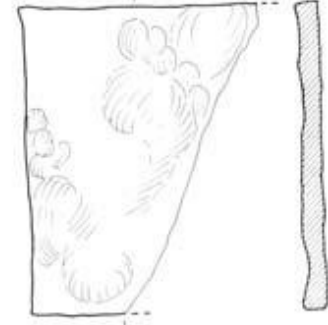

T55





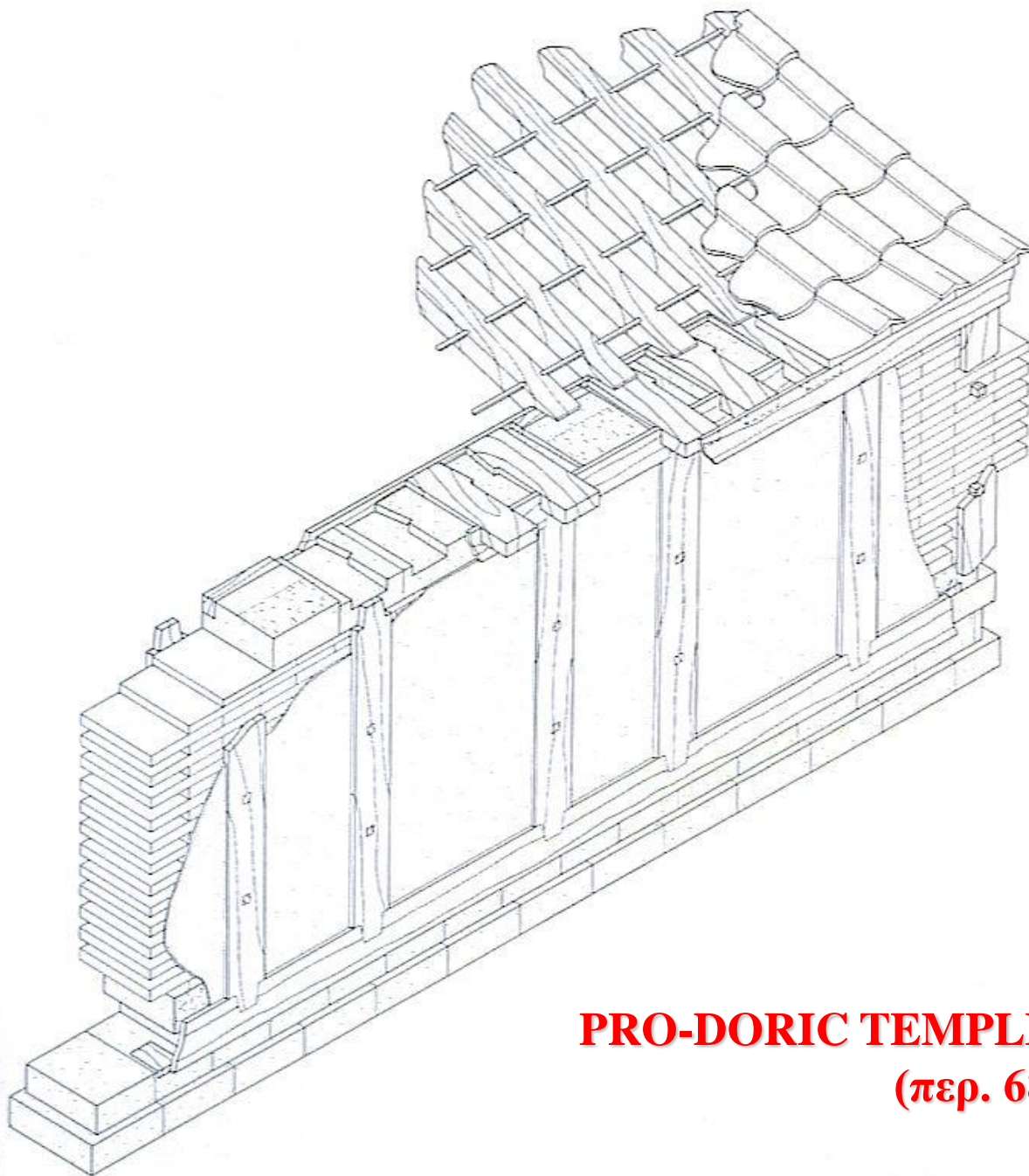

PRO-DORIC TEMPLE OF APOLLO, CORINTH
(περ. 680-650 π.Χ.)

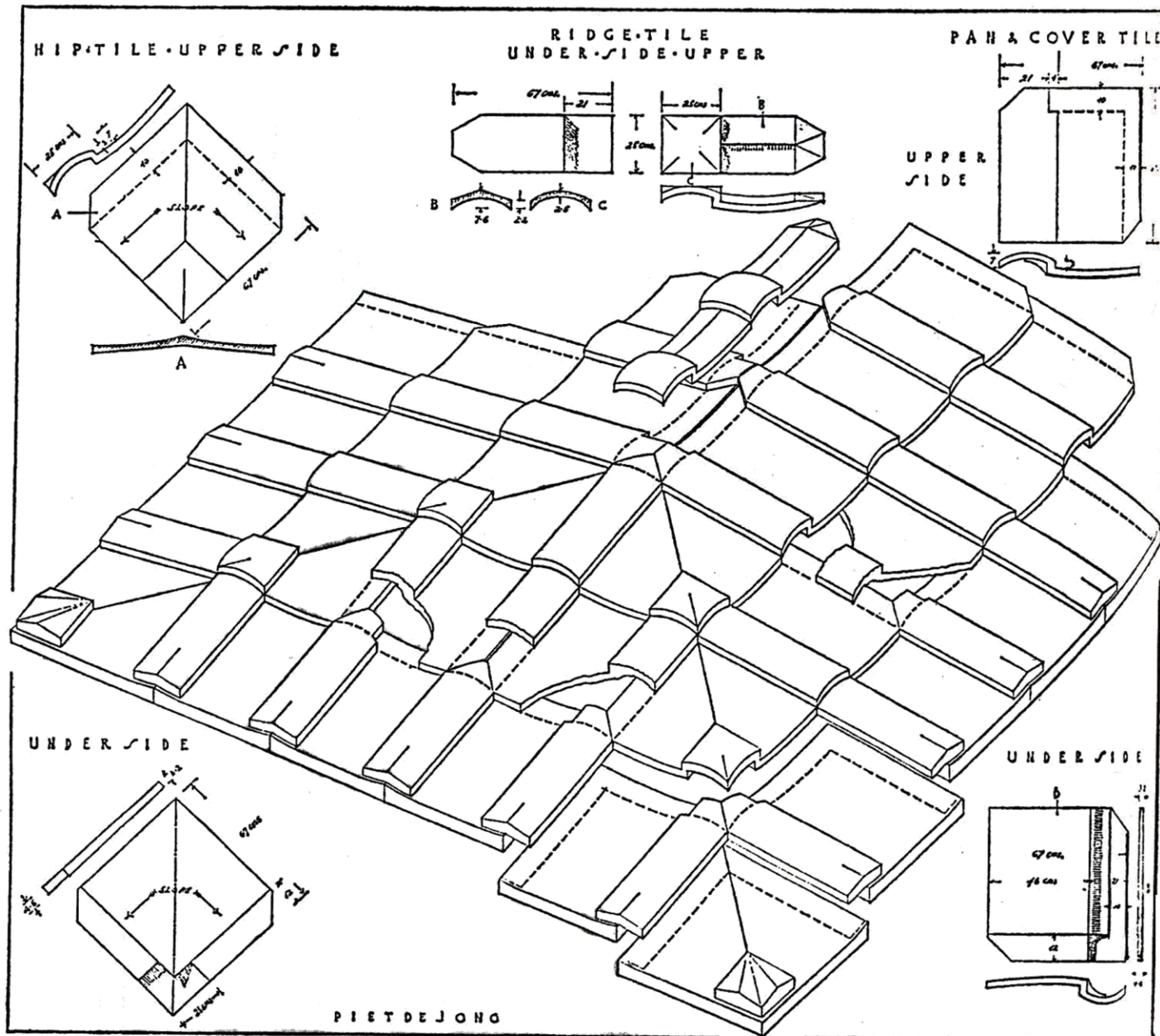

υποθετική
αναπαράσταση της
στέγης του πρώτου
ναού του Απόλλωνα
στην Αγορά της
Κορίνθου
(περ. 680-650 π.Χ.)



ΔΩΡΙΚΟΣ ΡΥΘΜΟΣ

ΘΡΥΓΚΟΣ

ΚΙΩΝ

ΣΤΥΛΟΒΑΤΗΣ

ΚΡΗΠΙ-
ΔΩΜΑ

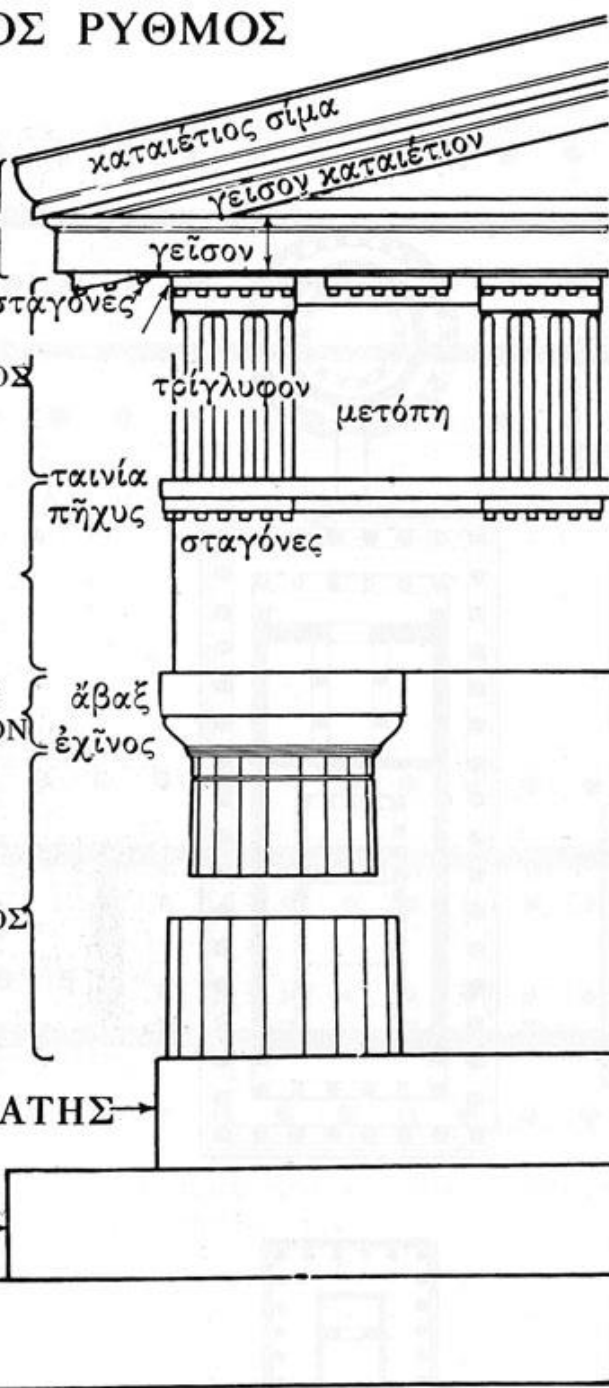

ΙΩΝΙΚΟΣ ΡΥΘΜΟΣ

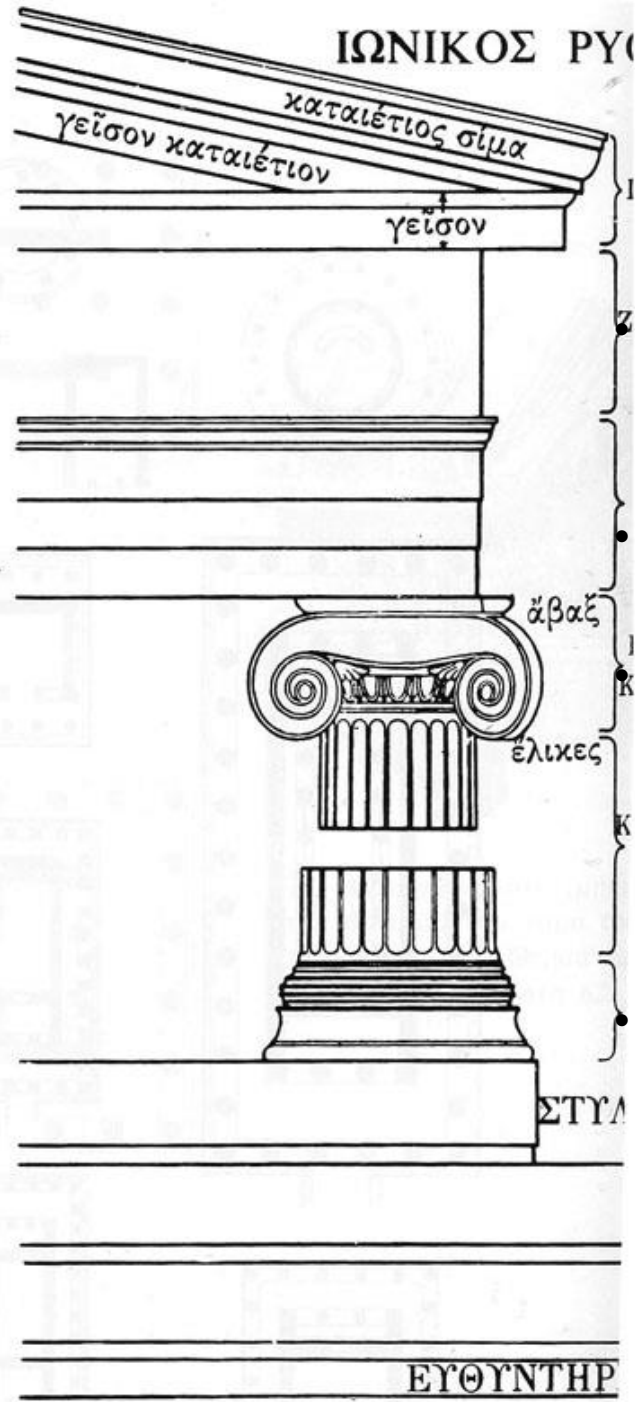

ΖΩΦΟΡΟΣ

ΕΠΙΣΤΥΛΙΟ

ΚΙΟΝΟΚΡΑΝΟ

ΒΑΣΗ

ΕΥΘΥΝΤΗΡ

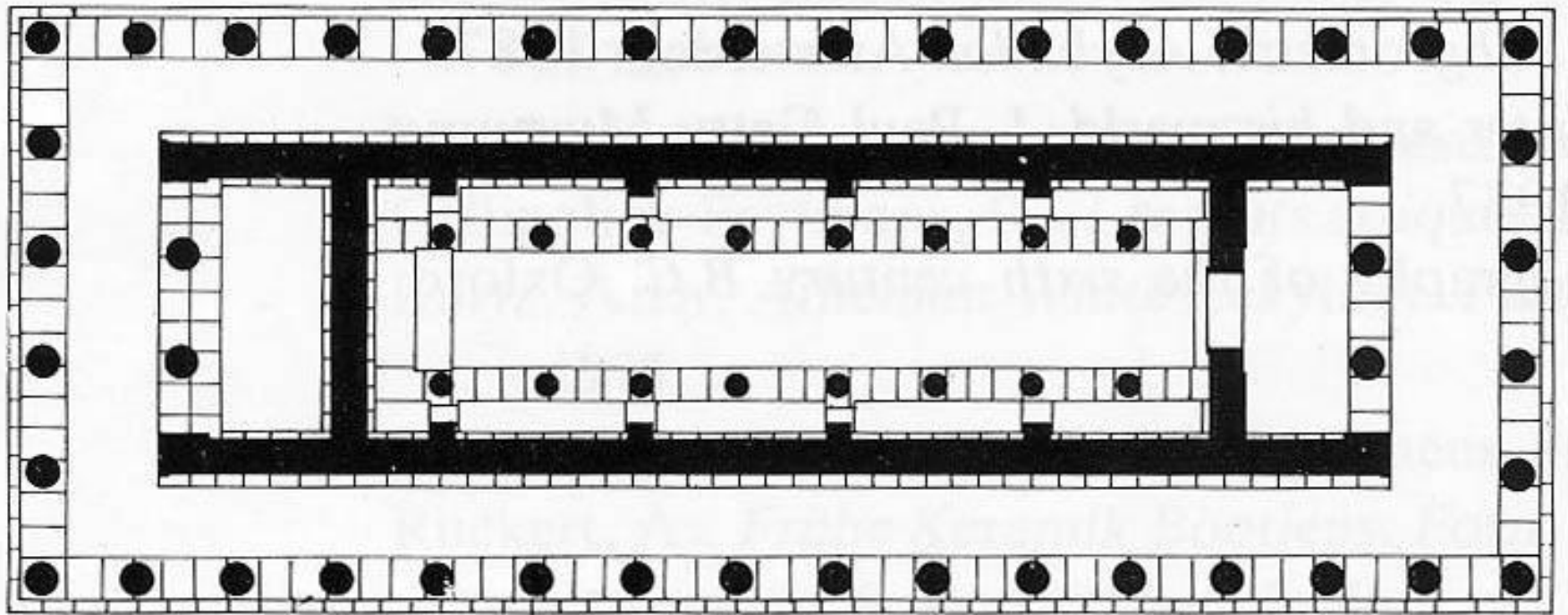

39. Κάτοψη αρχαϊκού Ηραίου Ολυμπίας.
Γύρω στο 600 π.Χ.





©2001 Brandon Cline



1. ΣΤΟΙΧΕΙΟ ΤΑΥΤΟΤΗΤΑΣ
2. ΜΙΚΡΗ ΟΜΑΔΑ

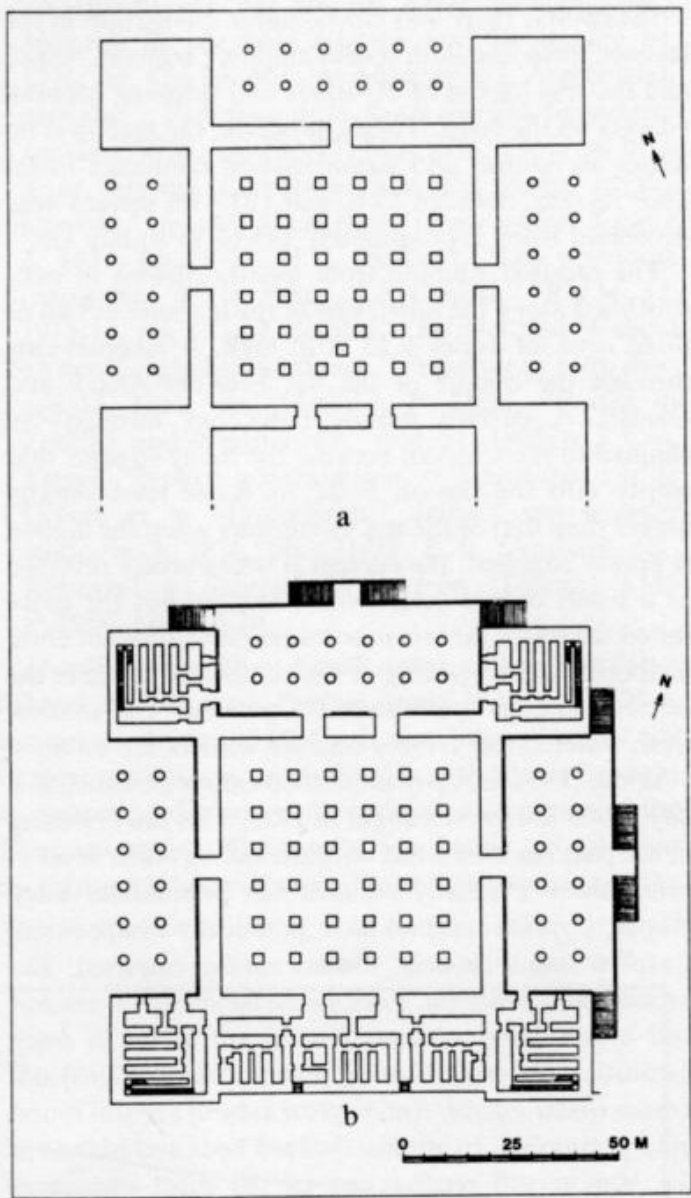
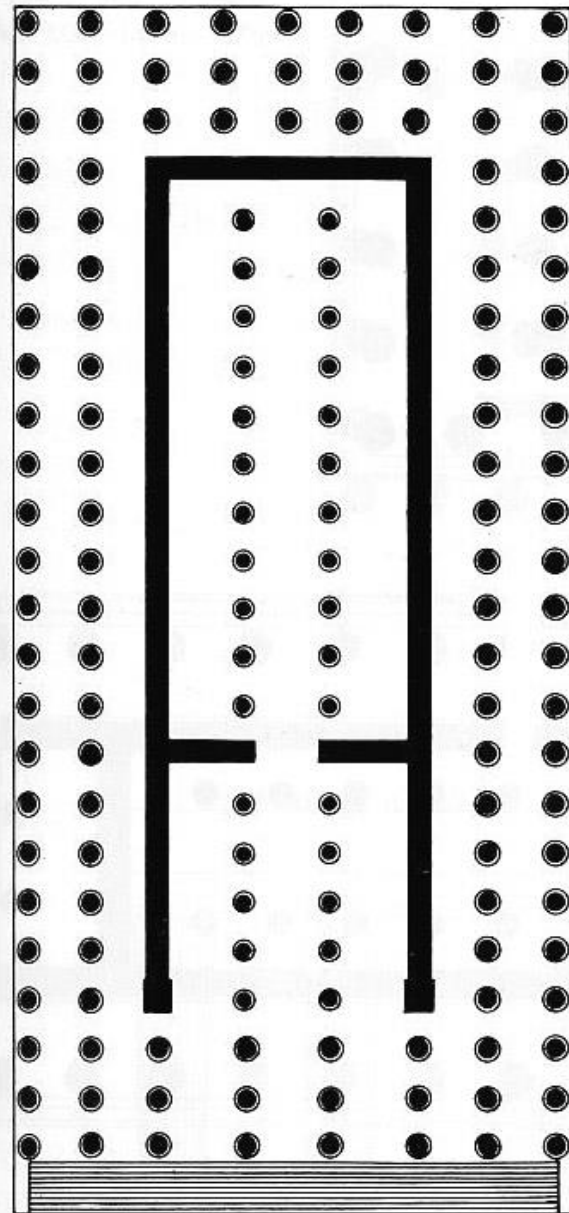
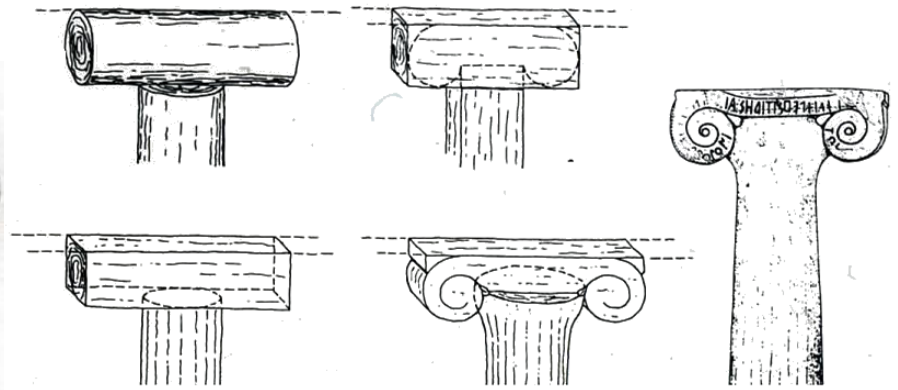

Figure 4. Partly restored ground plans of the Apadāna at Susa (a) and of the Apadāna at Persepolis (b). After Perrot and Schmidt.









αναθηματικός
ιωνικός κιονίσκος
από το Σαγκρί
Νάξου
(περ. 600 π.Χ.)



αρχαϊκό ιωνικό
κιονόκρανο

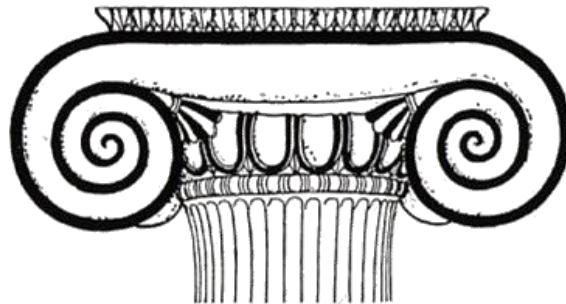

ιωνικό κιονόκρανο από το
αρχαϊκό Αρτεμίσιο της
Εφέσου (περ. 550 π.Χ.)

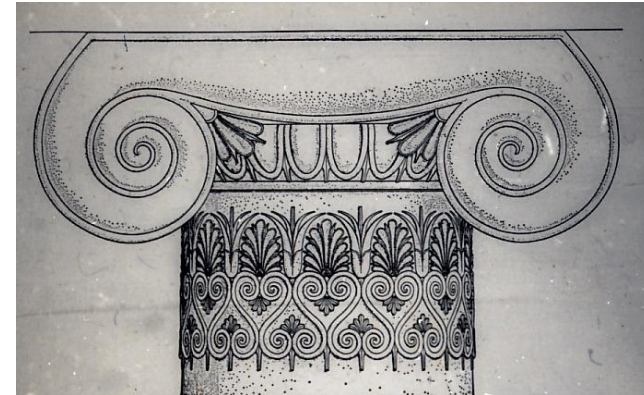

κιονόκρανο από το Ηραίο IV
στη Σάμο (περ. 480 π.Χ.)

Αιολικά κιονόκρανα

Πύλη στο Ισραήλ (Hazor, 9^{ος} αι.), κιονόκρανο από
την Νεάνδρια Τρωάδας (μέσα 6^{ου} αι.)

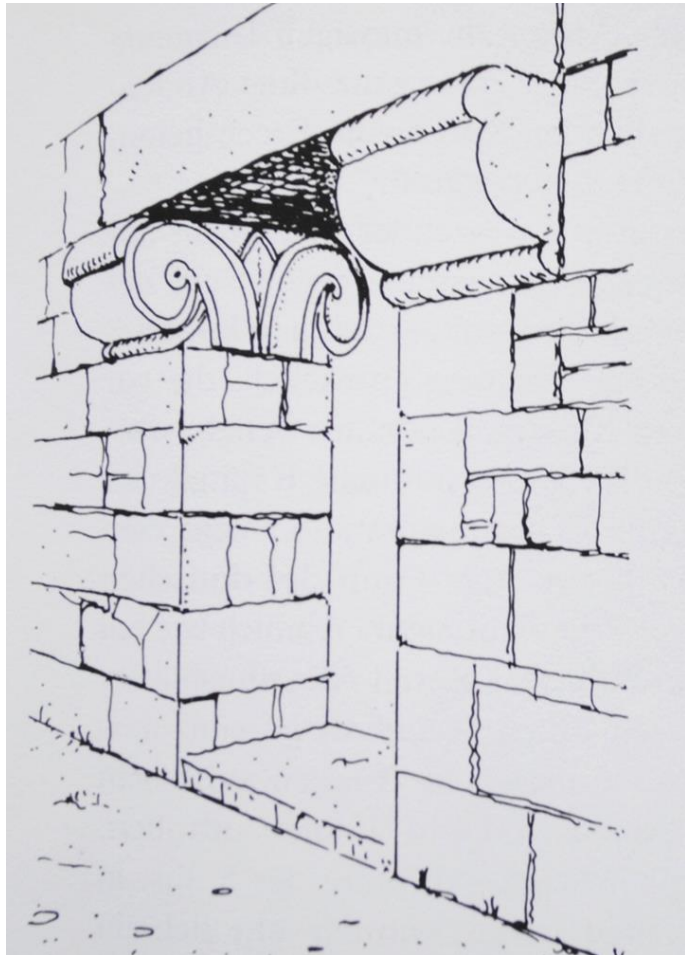

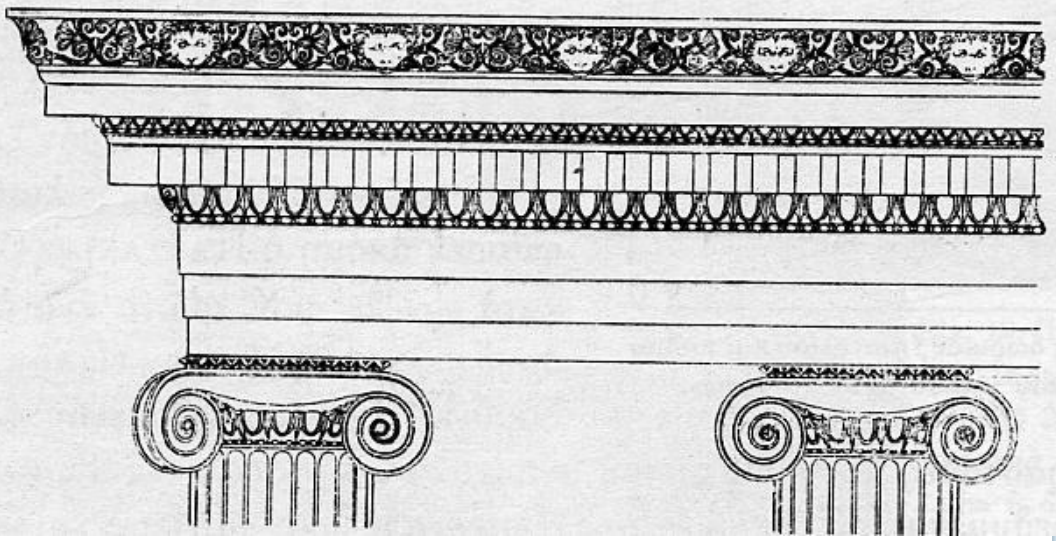
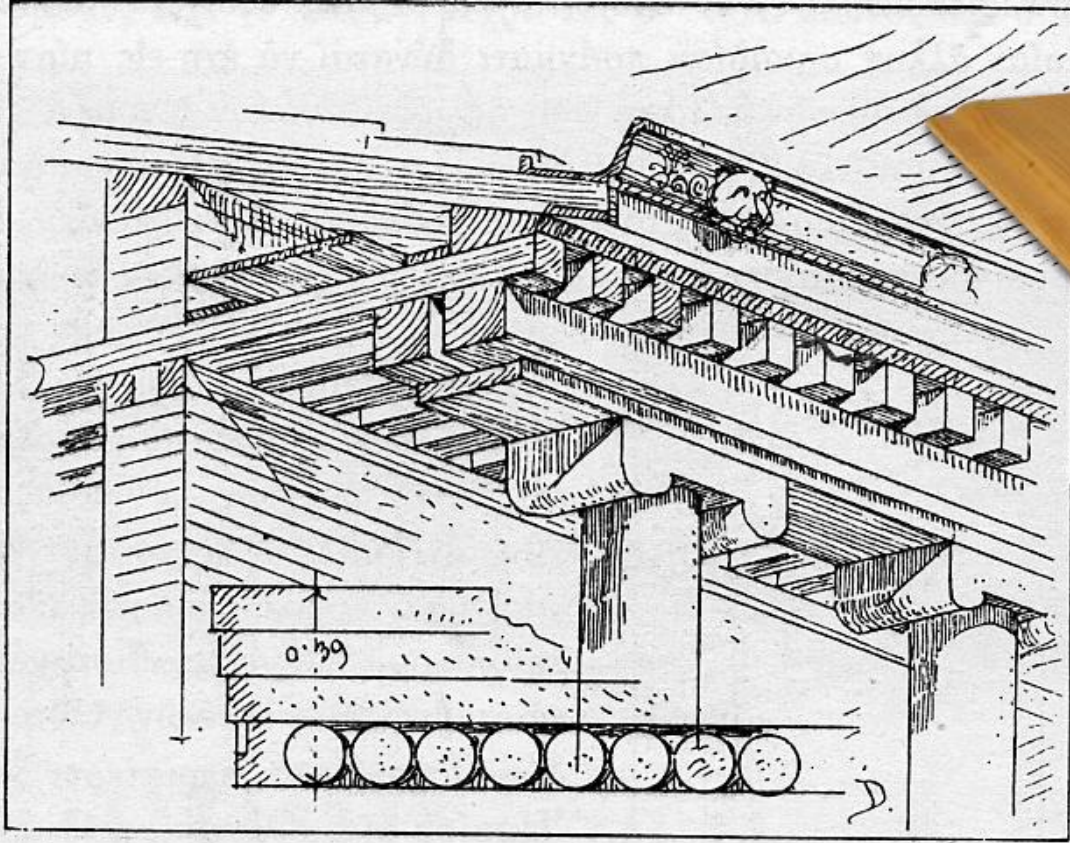

**ΚΑΤΑΓΩΓΗ ΤΟΥ ΙΩΝΙΚΟΥ ΡΥΘΜΟΥ ΑΠΟ ΤΗΝ
ΕΠΙΠΕΔΗ ΣΤΕΓΗ ΚΑΙ ΜΙΚΡΗΣ ΔΙΑΤΟΜΗΣ
ΕΥΛΕΙΑ**

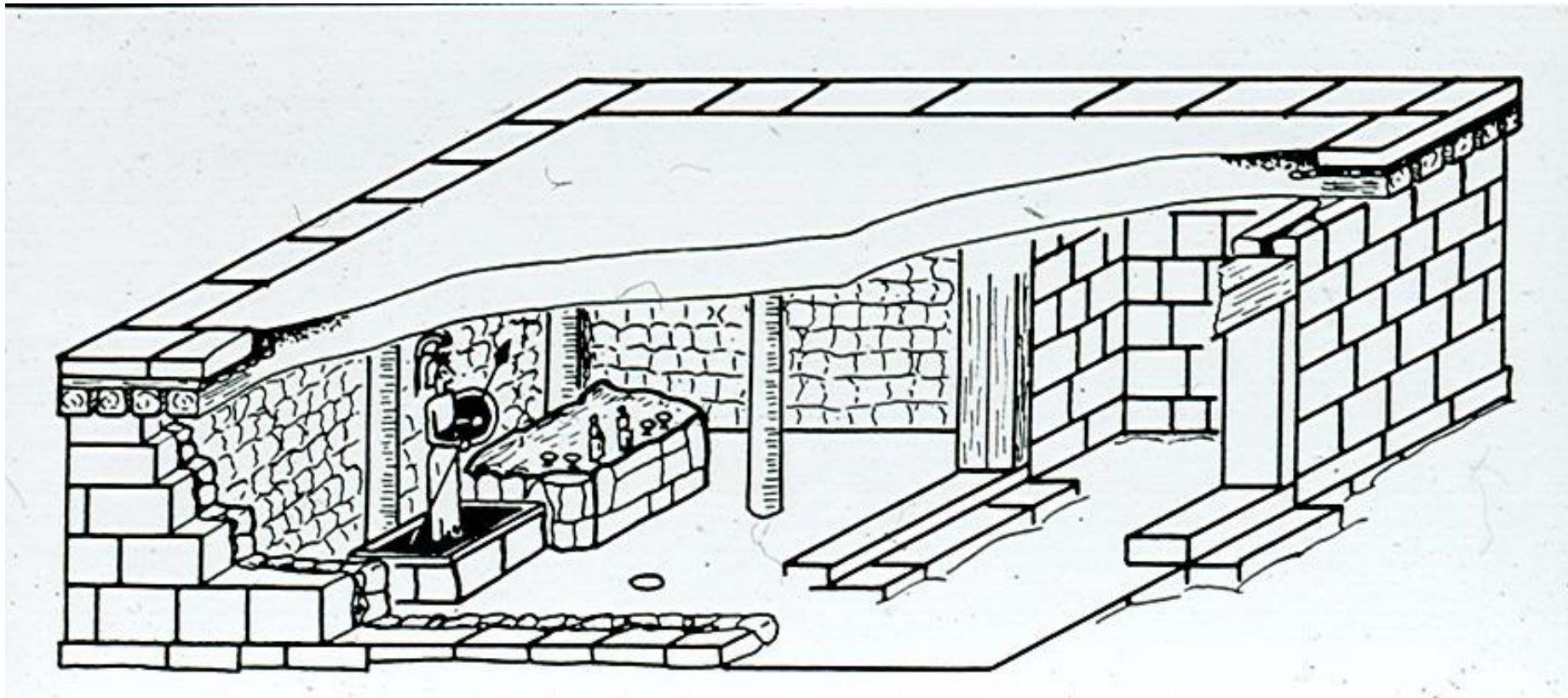

ΕΜΠΟΡΙΟ ΧΙΟΥ. Ισομετρική αναπαράσταση του ναού του 6^{ου} αιώνα π.Χ.



ΕΜΠΟΡΙΟ ΧΙΟΥ.
Ο ναός της Αθηνάς
(δοτικός τοίχος)

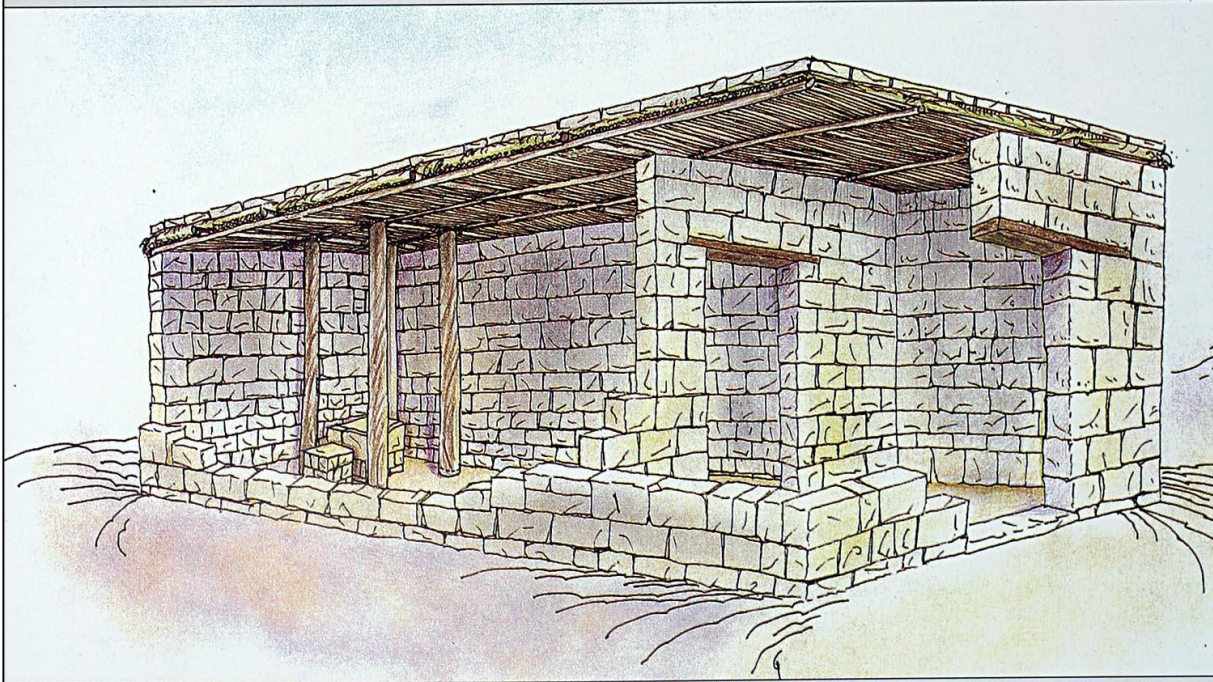

δοκιμαστική
αναπαράσταση

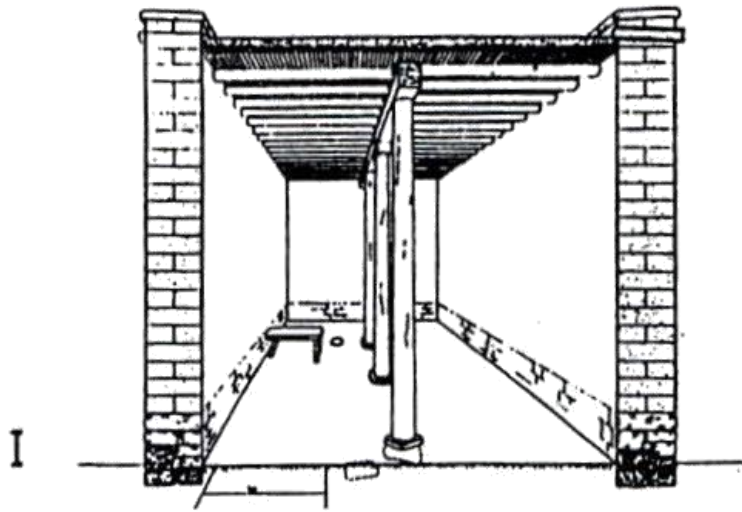

I. αρχές 8ου αι. π.Χ.

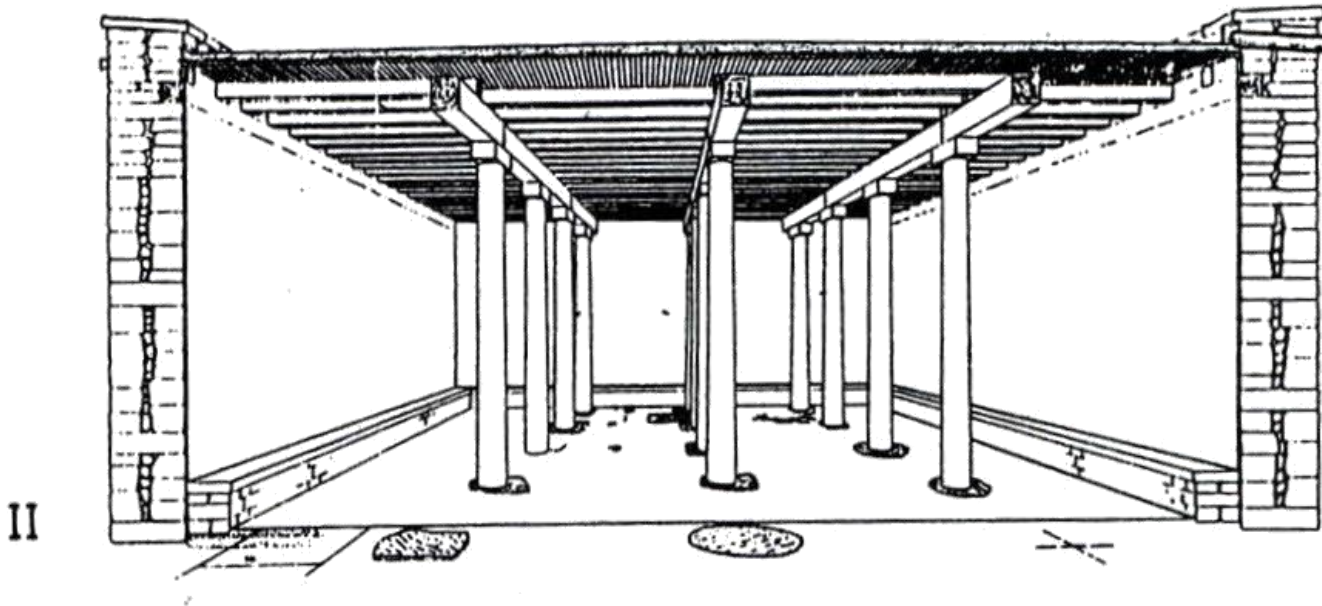

II. Δεύτερο μισό
8^{ου} αι. π.Χ.
(περ. 730 π.Χ.)

Ναός του Διονύσου στα Ύγρια Νάξου. Φάσεις Ναού I-II

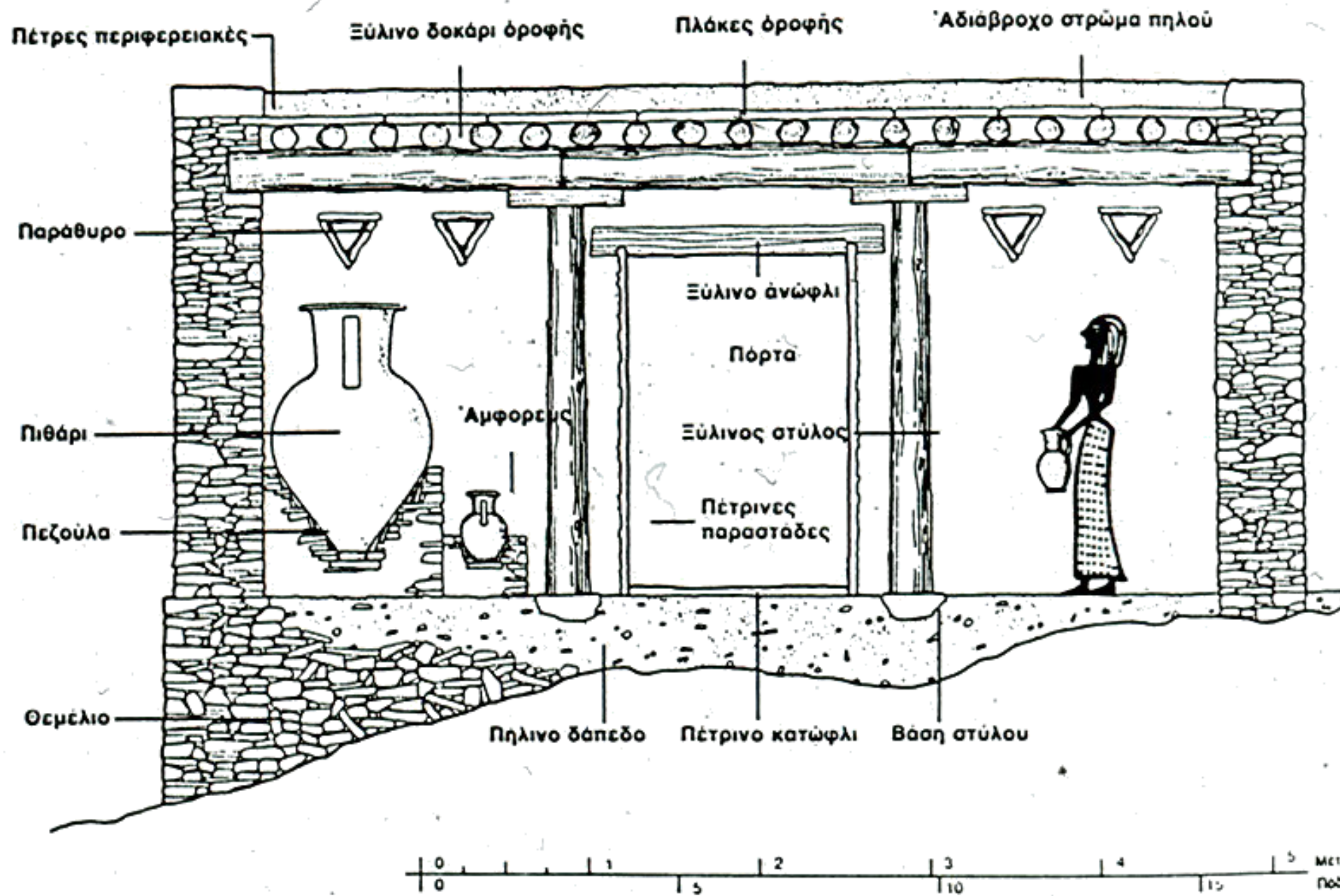



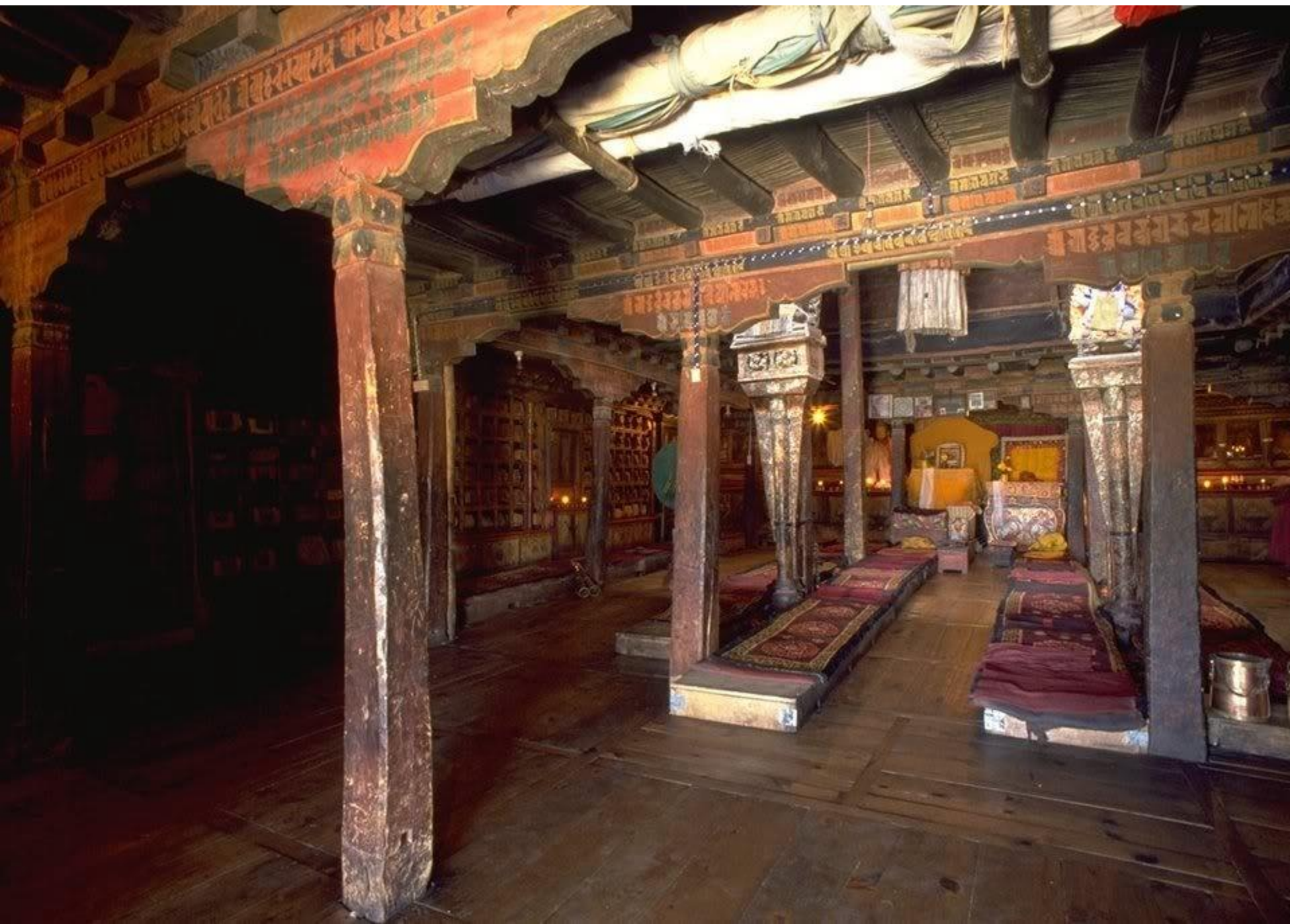



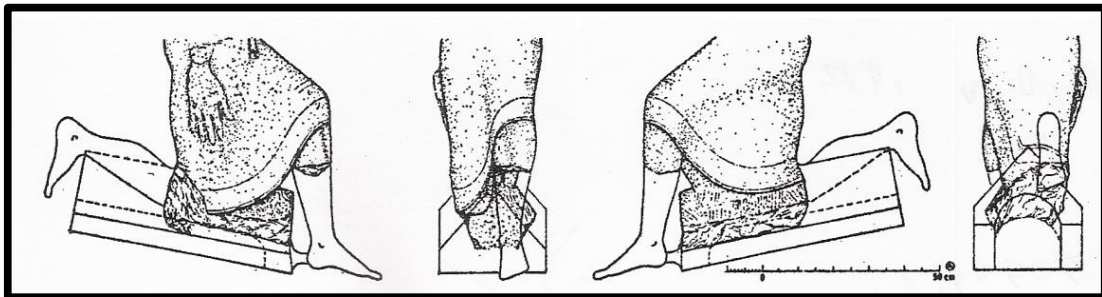
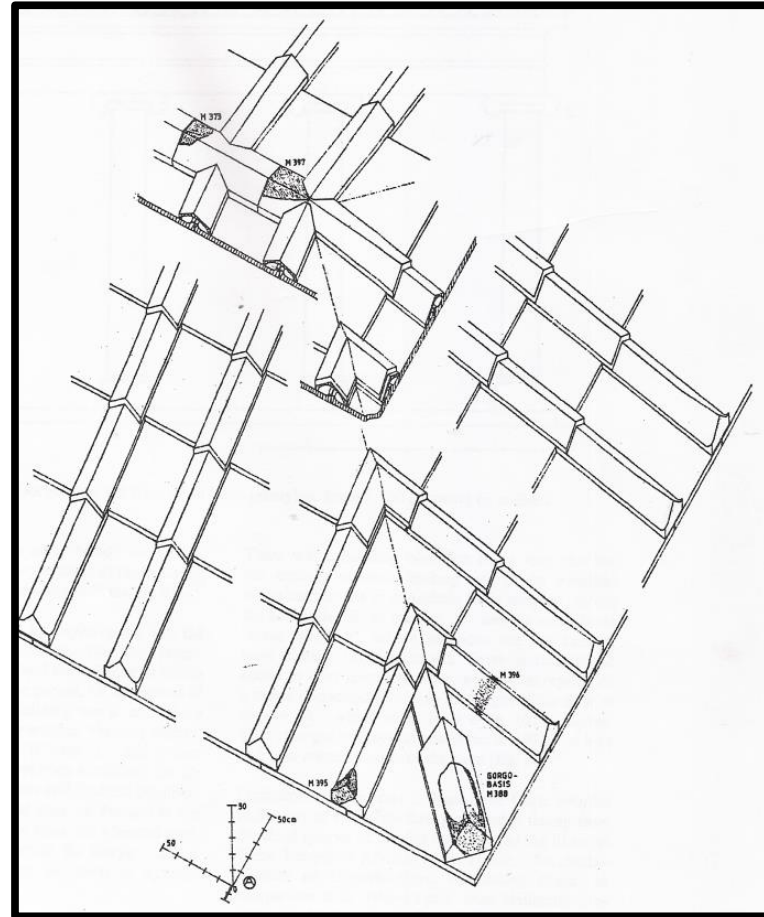
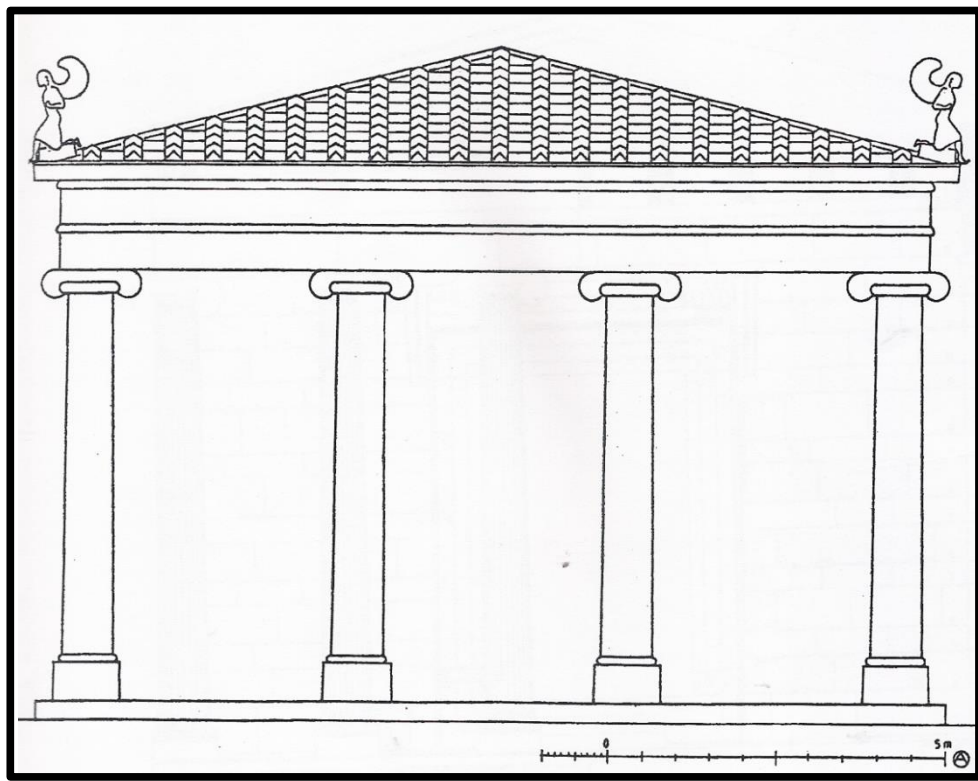

Πάρος. «Ναός Γοργούς» (υποθ. Ohnesorg)

ΒΑΣΗ ΚΙΟΝΟΣ ΣΤΟ ΗΡΑΙΟ ΤΗΣ ΣΑΜΟΥ



ΚΩΔΩΝΟΣΧΗΜΗ ΙΩΝΙΚΗ ΒΑΣΗ ΣΤΗ ΣΤΟΑ ΤΩΝ ΑΘΗΝΑΙΩΝ ΣΤΟΥΣ ΔΕΛΦΟΥΣ (479 Π.Χ.)



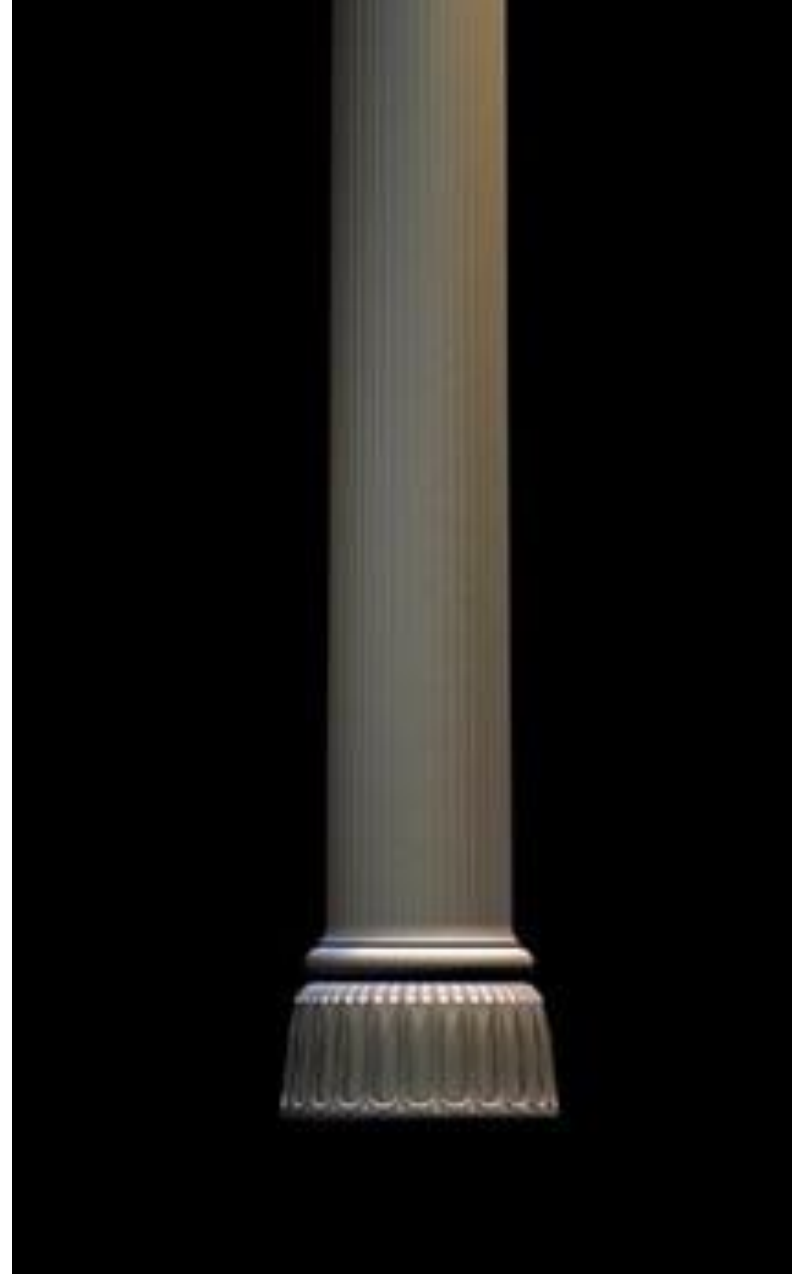



O. Broneer, "The tent of Xerxes and the Greek theater", in: *University of California Publications in Classical Archaeology* 1 (1929) 305-312.

D.B.. Thompson, "The Persian spoils in Athens" in: Saul S. Weinberg (ed.), *The Aegean and the Near East. Studies presented to Hetty Goldman* (1956 Locust Valley) 281-291





- ΒΑΣΗ ΚΙΟΝΟΣ ΣΤΑ ΔΙΔΥΜΑ ΤΗΣ ΜΙΛΗΤΟΥ. 4^{ος} ΑΙ. π.Χ.



- ΑΤΤΙΚΗ ΒΑΣΗ ΚΙΟΝΟΣ ΣΤΟ ΕΡΕΧΘΕΙΟΝ. ΑΚΡΟΠΟΛΗ ΑΘΗΝΩΝ, 5^{ος} ΑΙ. Π.Χ.

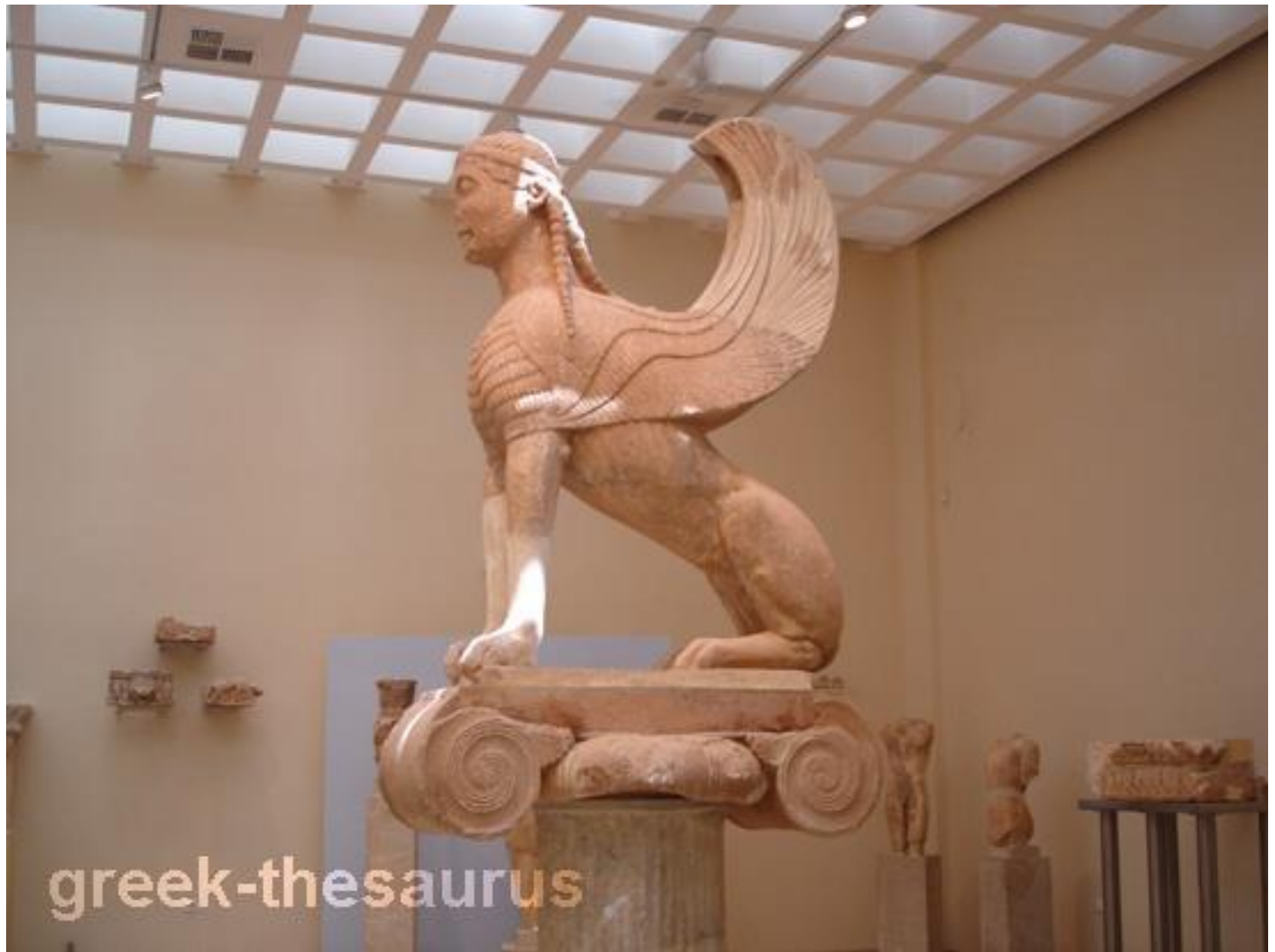

[greek-thesaurus](#)

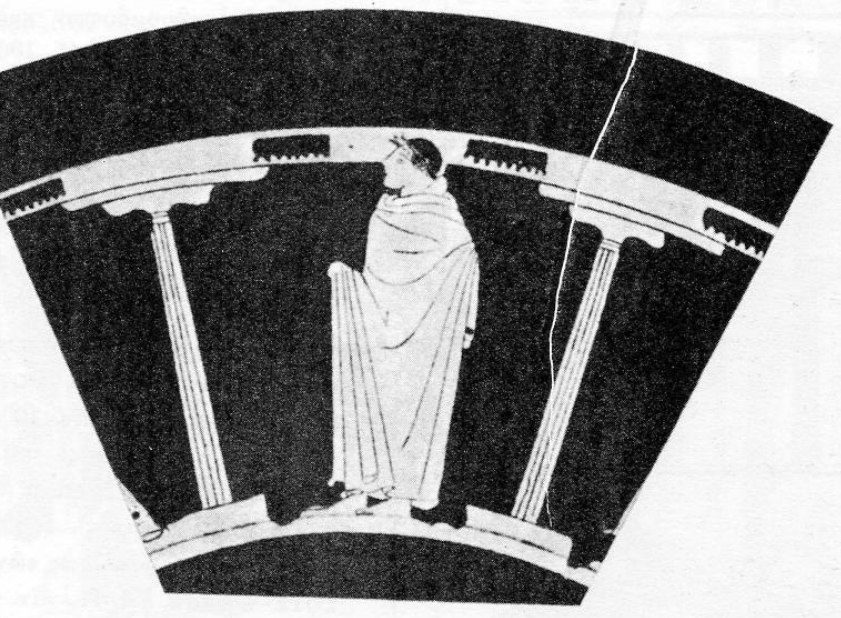

Η ΚΑΤΑΓΩΓΗ ΤΟΥ ΙΩΝΙΚΟΥ ΚΙΟΝΟΚΡΑΝΟΥ ΑΠΟ ΤΟ ΣΑΓΜΑ







འཇམ་གཟའ་མཚོ་
འཇམ་གཟའ་མཚོ་
DONATION
BOX

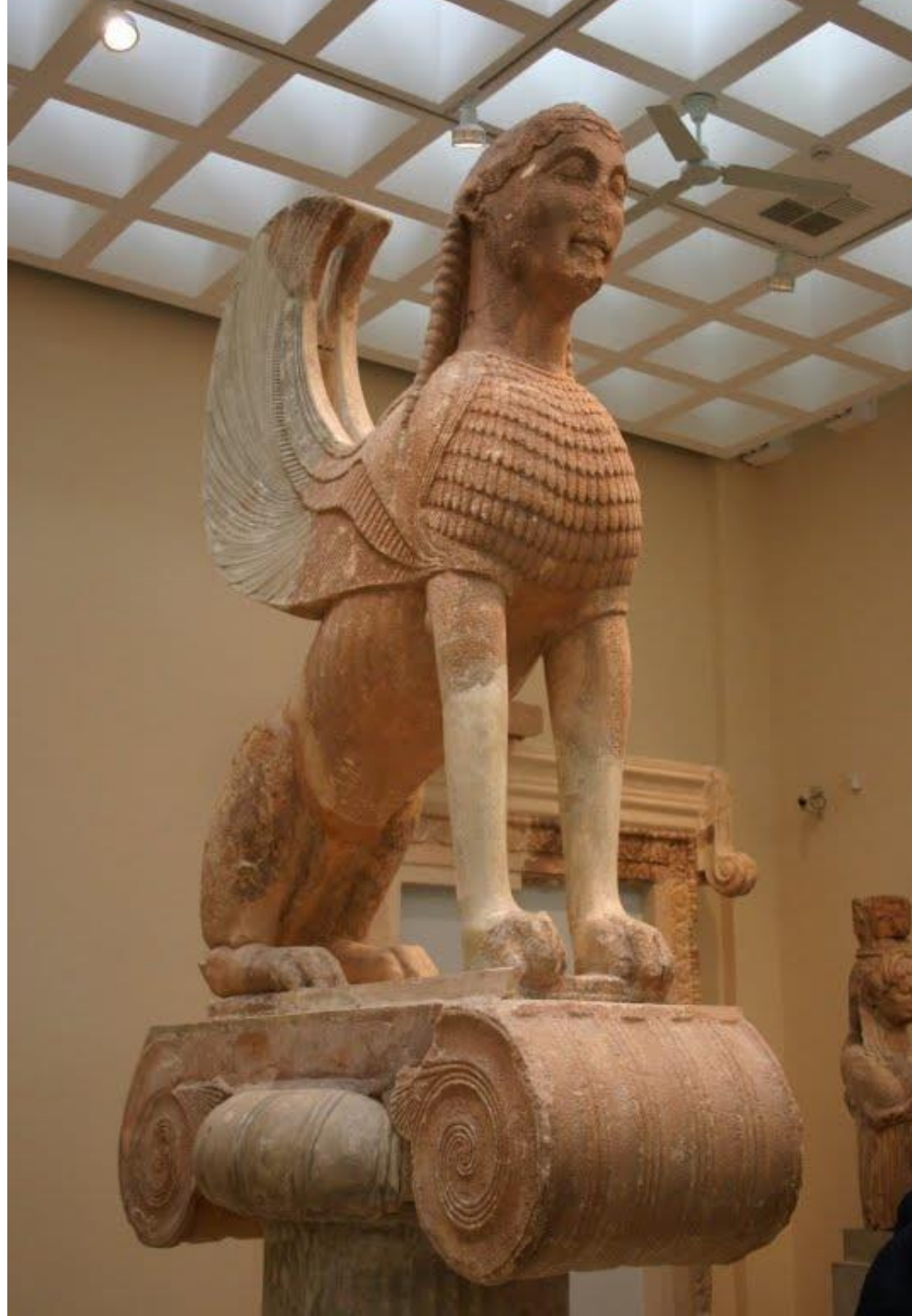

ΙΩΝΙΚΟ ΚΙΟΝΟΚΡΑΝΟ. ΠΑΡΟΣ, 550 π.Χ.

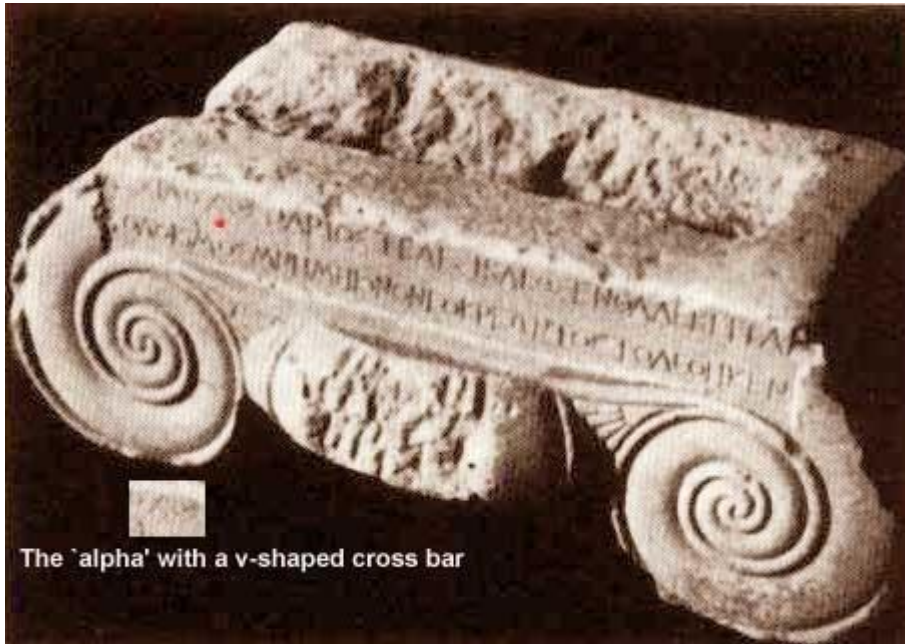

The 'alpha' with a v-shaped cross bar

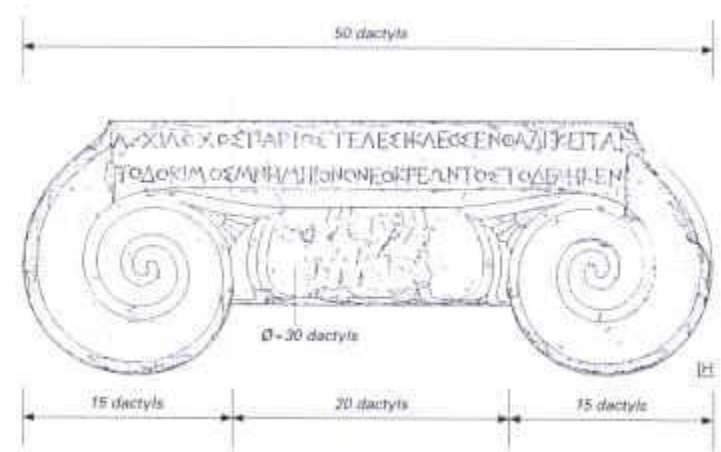

ΙΩΝΙΚΟ ΚΙΟΝΟΚΡΑΝΟ.
ΩΡΩΠΟΣ, 500 π.Χ.



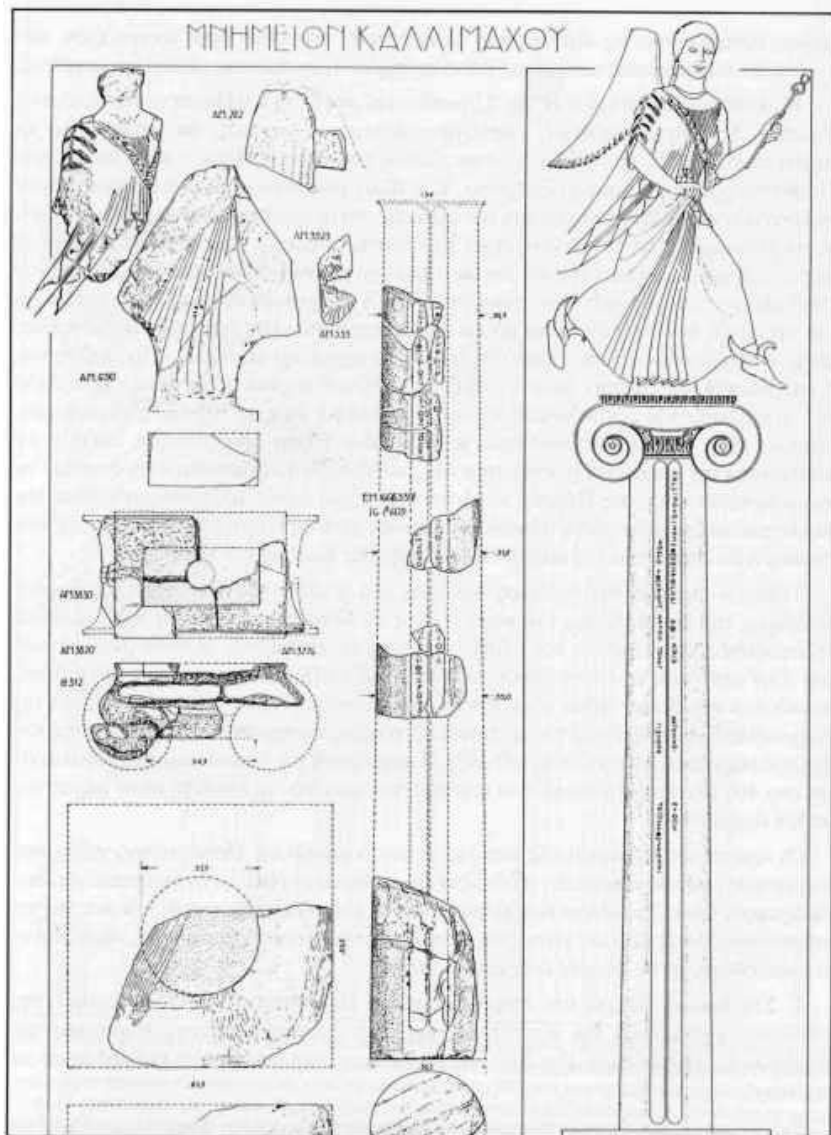

Εικ.20 Θραύσματα και σχεδιαστική αποκατάσταση του μνημείου του Καλλιμάχου



ΚΙΟΝΟΚΡΑΝΟ ΑΠΟ ΤΑ ΥΡΙΑ ΤΗΣ ΝΑΞΟΥ

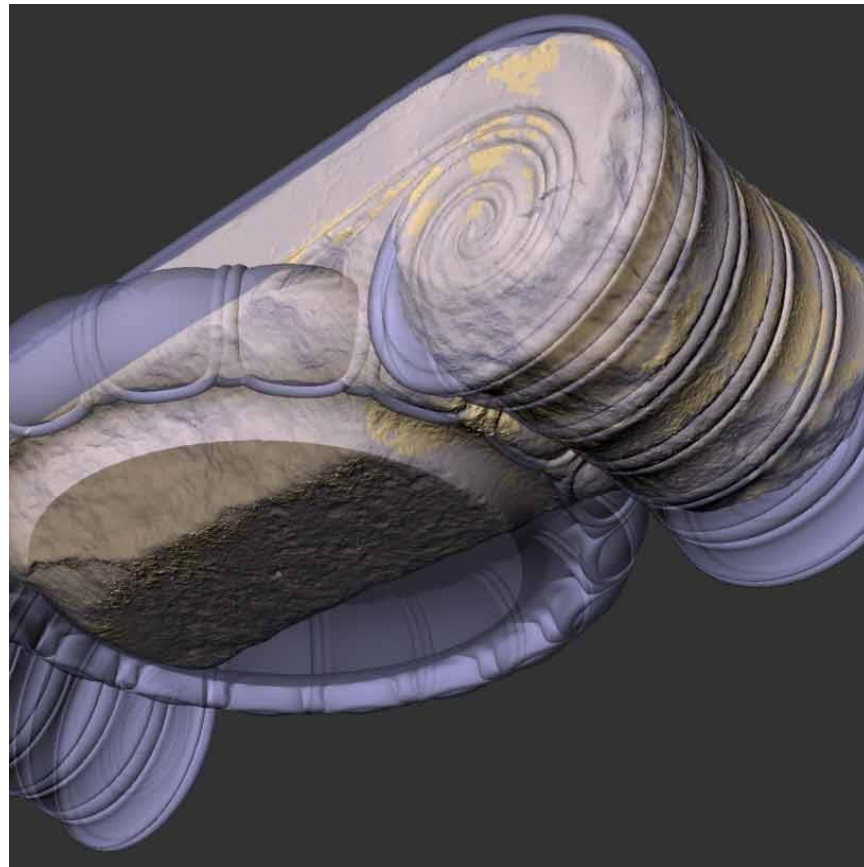

ΤΟ ΑΣΙΑΤΙΚΟ ΚΑΙ ΤΟ ΝΗΣΙΩΤΙΚΟ ΙΩΝΙΚΟ ΚΙΟΝΟΚΡΑΝΟ

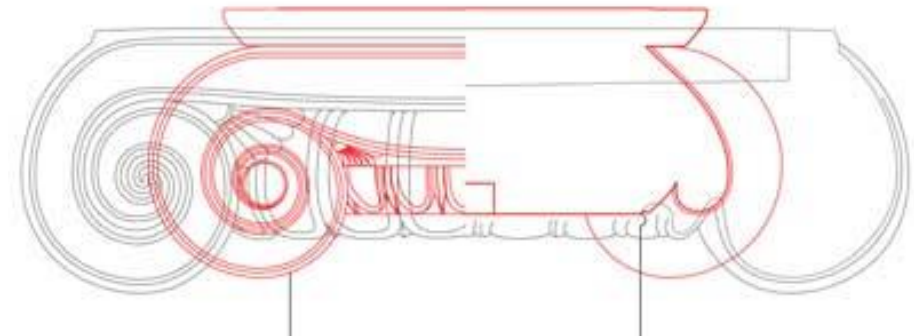
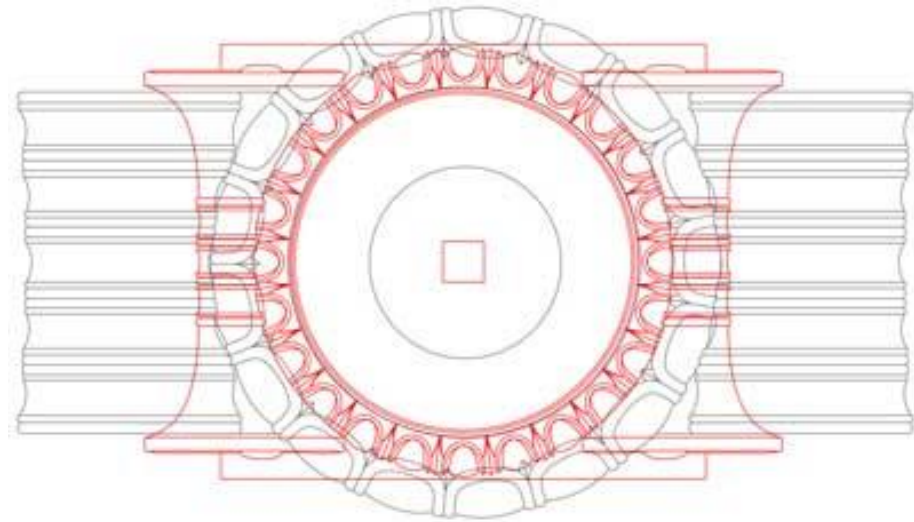
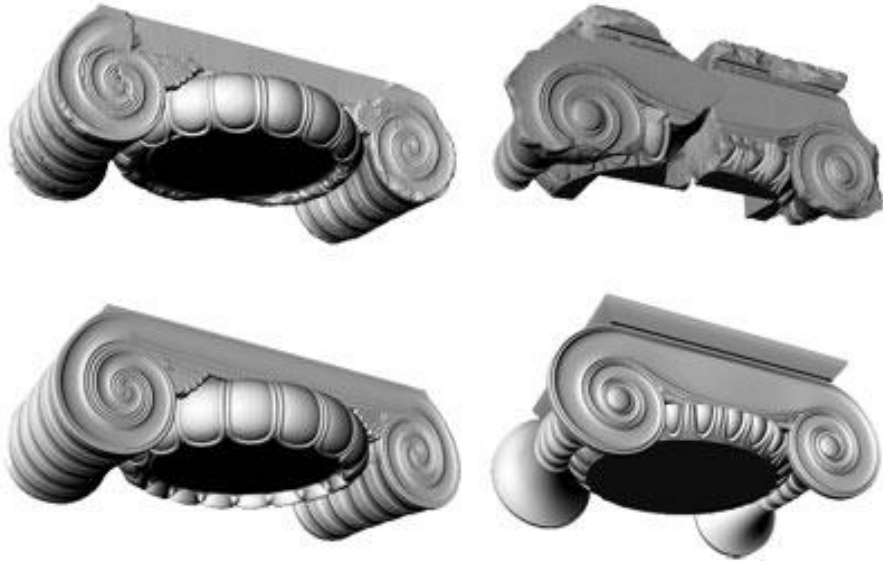

ΣΑΡΔΕΙΣ



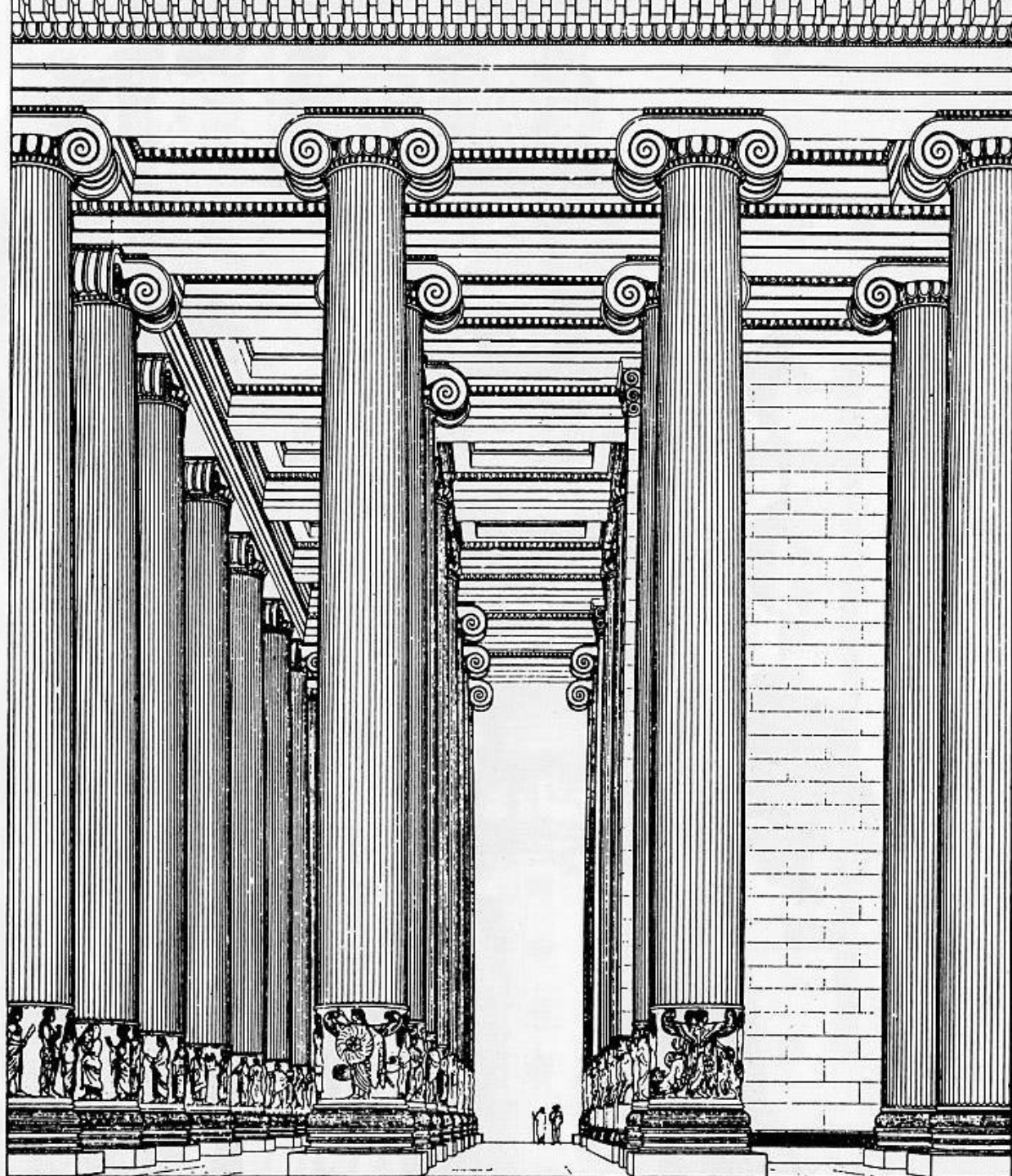



ΙΩΝΙΚΟ ΚΙΟΝΟΚΡΑΝΟ ΣΤΟ ΠΑΝΕΠΙΣΤΗΜΙΟ
ΑΘΗΝΩΝ

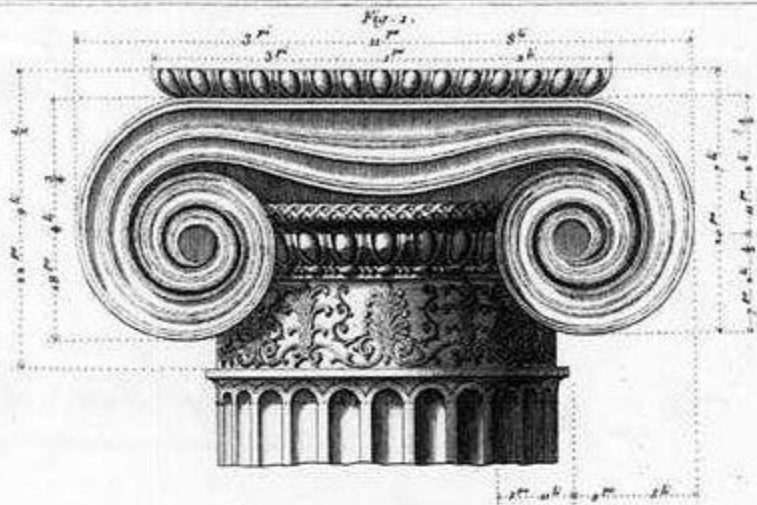

Fig. 2.

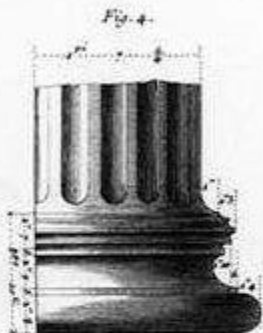

Fig. 4.

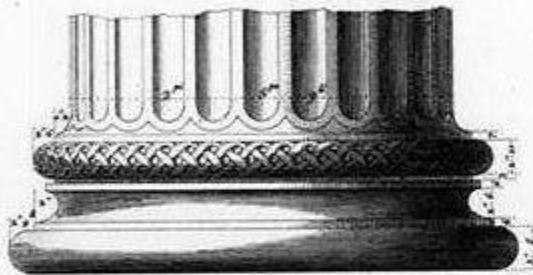

Fig. 5.

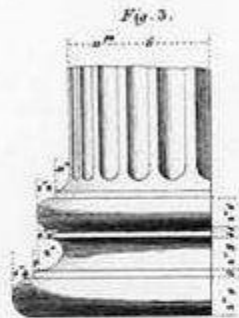

Fig. 3.

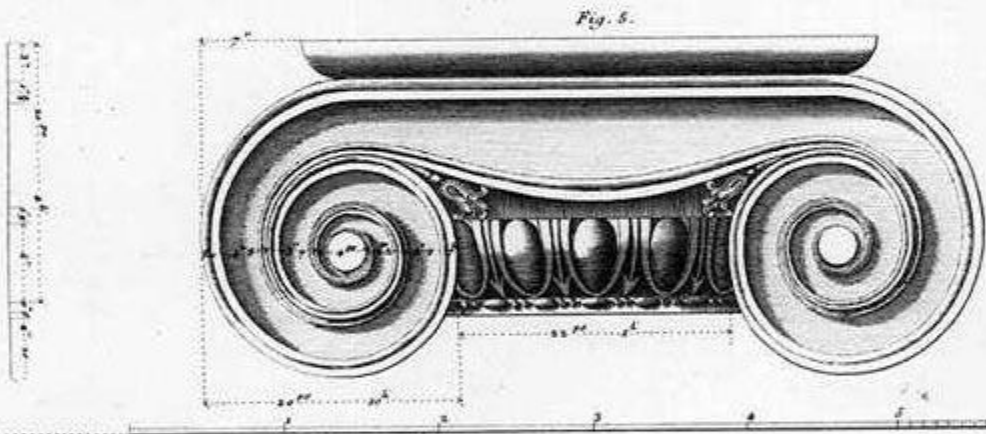

Fig. 6.



Fig. 7.

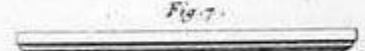

Fig. 8.

Ionic Capital



ΙΩΝΙΚΟ ΚΙΟΝΟΚΡΑΝΟ ΣΤΑ ΠΡΟΠΥΛΑΙΑ ΤΩΝ
ΑΘΗΝΩΝ. ΨΗΦΙΑΚΗ ΑΠΟΚΑΤΑΣΤΑΣΗ



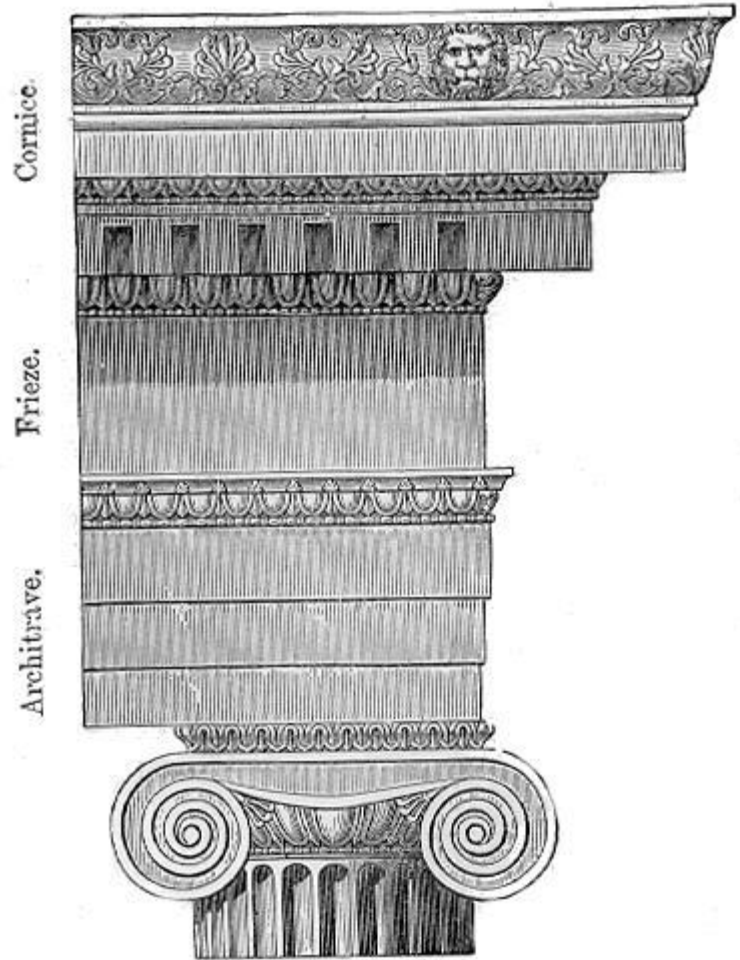
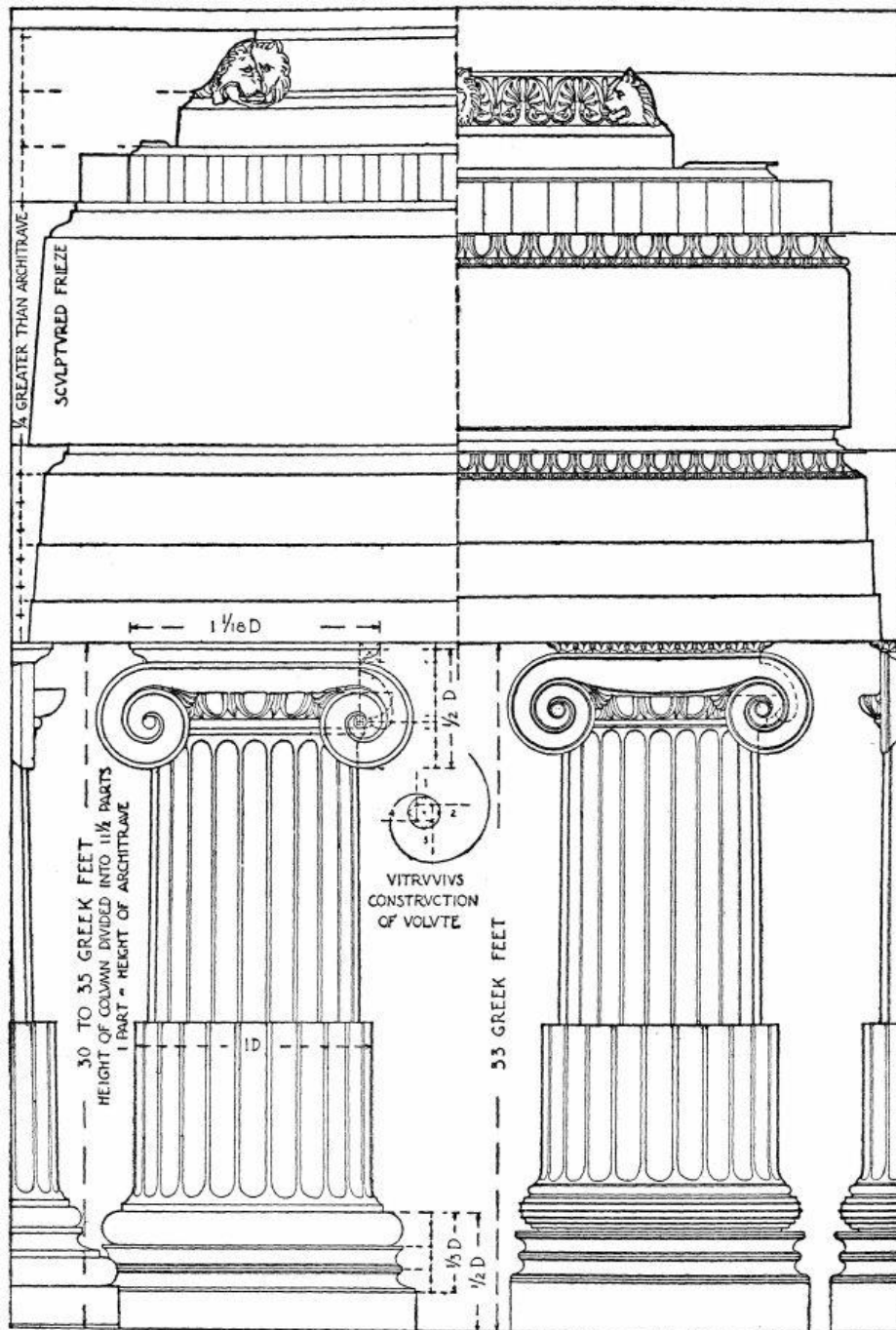

Ionic Entablature from the Temple of Minerva Polias at Priene.

ΔΩΡΙΚΟΣ ΡΥΘΜΟΣ

ΘΡΥΓΚΟΣ

ΚΙΩΝ

ΣΤΥΛΟΒΑΤΗΣ

ΚΡΗΠΙ-ΔΩΜΑ

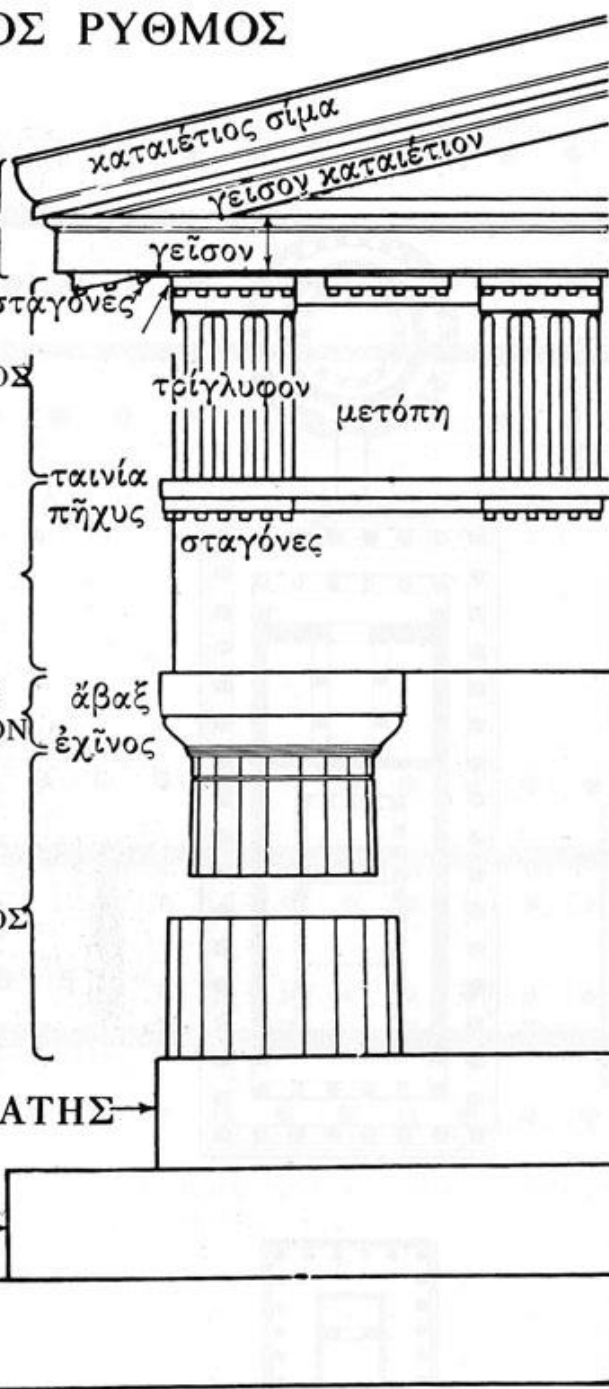

ΙΩΝΙΚΟΣ ΡΥΘΜΟΣ

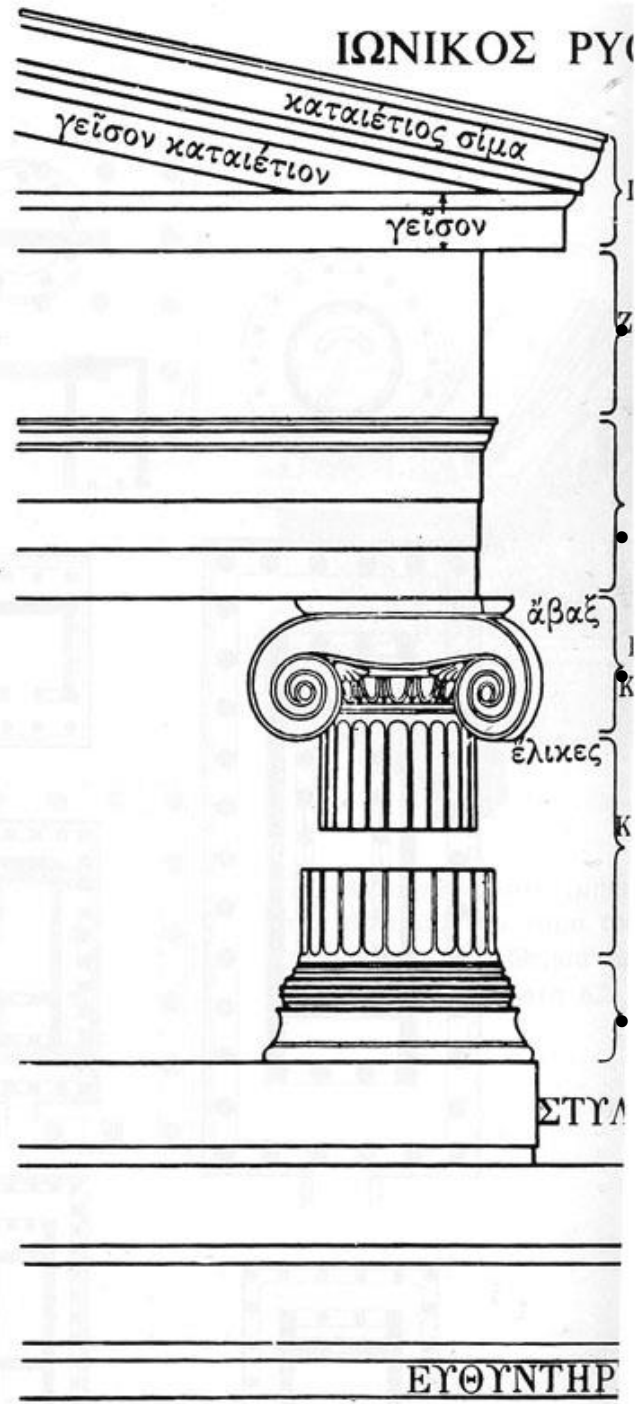

ΖΩΦΟΡΟΣ

ΕΠΙΣΤΥΛΙΟ

ΚΙΟΝΟΚΡΑΝΟ

ΒΑΣΗ



Hekatompedos 1

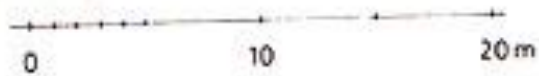

● Brunnen

Altar 3

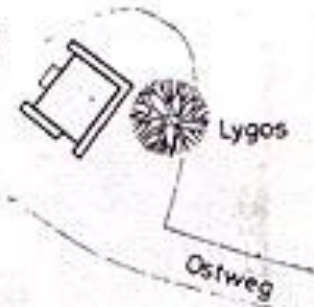

● Basis

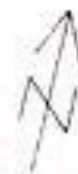

Hekatompedos 1A

● Brunnen

Altar 4



● Brunnen

● Basis

Substweg

ΤΟ ΗΡΑΙΟΝ Ι ΤΗΣ ΣΑΜΟΥ (700; - 670 π.Χ.).

ΤΟ ΗΡΑΙΟΝ ΙΙΙ ΚΑΙ ΙV ΤΗΣ ΣΑΜΟΥ

- ΗΡΑΙΟΝ ΙΙΙ. ΚΟΛΟΣΣΙΚΟΣ ΔΙΠΤΕΡΟΣ ΝΑΟΣ ΤΟΥ ΡΟΙΚΟΥ – ΚΑΙ ΤΟΥ ΘΕΟΔΩΡΟΥ (570 – 560). «ΛΑΒΥΡΙΝΘΟΣ». ΚΑΤΕΔΑΦΙΣΤΗΚΕ ΑΜΕΣΩΣ ΚΑΘΩΣ ΘΕΜΕΛΙΩΘΗΚΕ ΣΤΟ ΣΑΘΡΟ ΕΔΑΦΟΣ ΤΟΥ ΕΛΟΥΣ.
- ΗΡΑΙΟΝ ΙV. ΔΙΠΤΕΡΟΣ ΝΑΟΣ ΤΟΥ ΤΥΡΑΝΝΟΥ ΠΟΛΥΚΡΑΤΗ (550- 500/480). ΚΙΟΝΟΚΡΑΝΑ ΧΩΡΙΣ ΕΛΙΚΕΣ ΣΤΟΝ ΠΡΟΝΑΟ. ΞΥΛΙΝΑ ΕΠΙΣΤΥΛΙΑ.
- ΧΑΡΑΚΤΗΡΙΣΤΙΚΗ Η ΕΛΛΕΙΨΗ ΟΠΙΣΘΟΝΑΟΥ.
- ***Το Ευπαλίνειο όρυγμα** Η. J. Kienast, *The aqueduct of Eupalinos in Samos*, Αθήνα 2004.

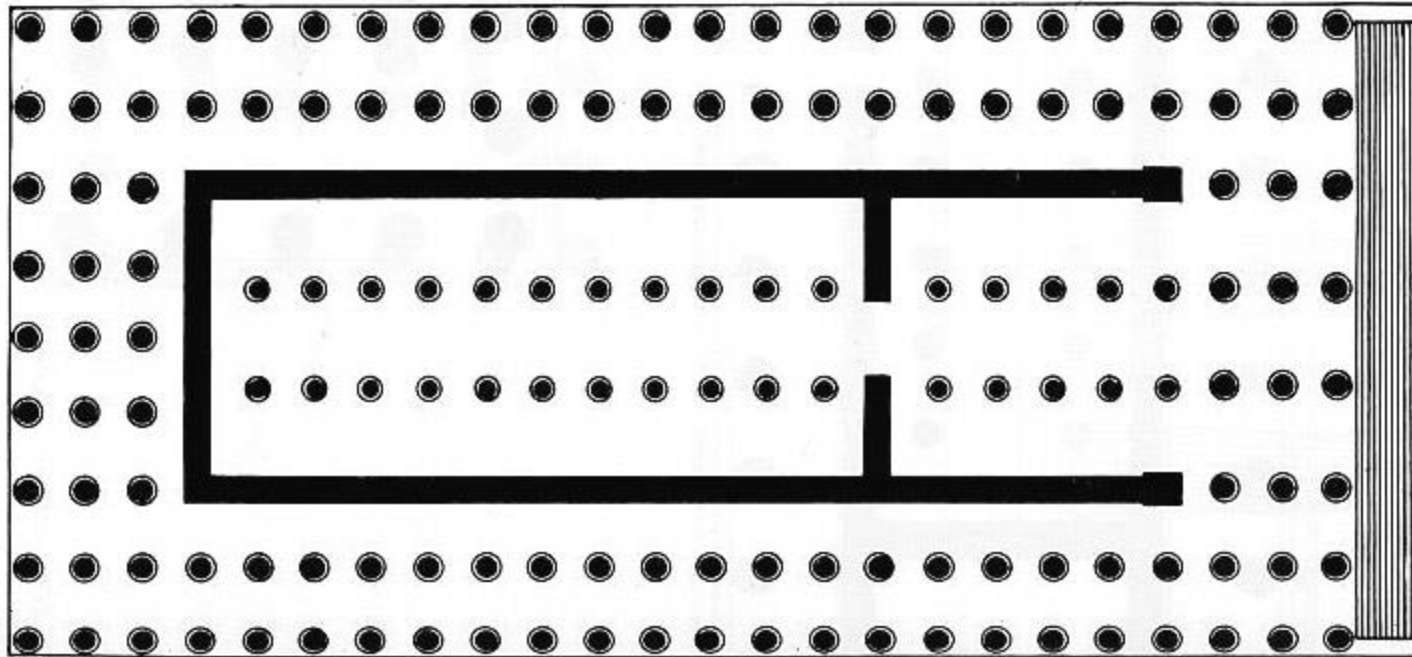

- Ο ΑΡΧΑΪΚΟΣ ΝΑΟΣ ΙV ΤΗΣ ΗΡΑΣ ΣΤΗΝ ΣΑΜΟ (ΝΑΟΣ ΤΟΥ ΠΟΛΥΚΡΑΤΗ)



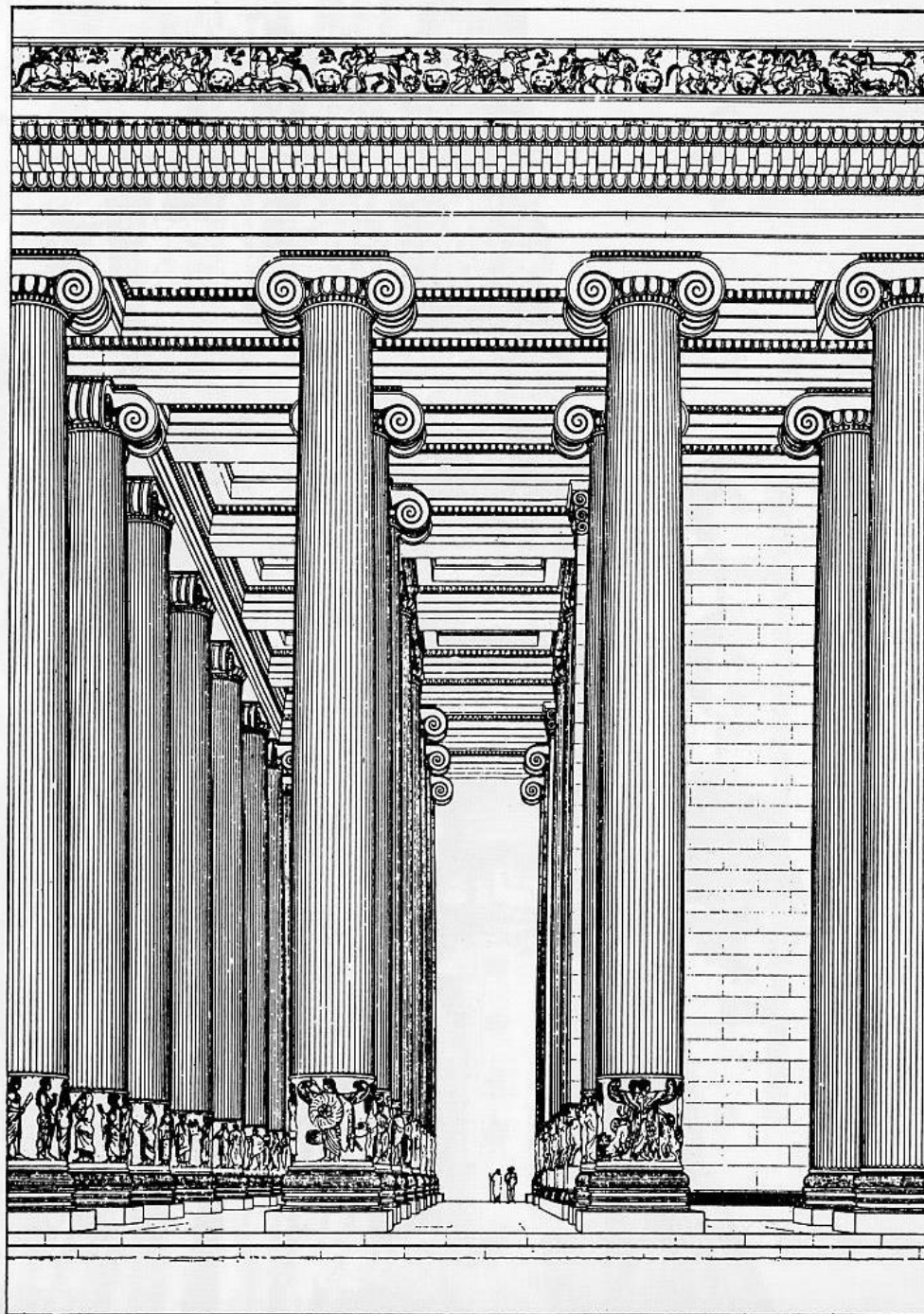

ΑΡΧΑΪΚΟΣ ΝΑΟΣ ΤΗΣ
ΑΡΤΕΜΗΣ ΣΤΗΝ ΕΦΕΣΟ.
(560 π.Χ.). **ΣΤΕΓΑΖΕ ΤΟ
ΔΙΑΣΗΜΟ ΕΟΑΝΟ ΤΗΣ
ΘΕΑΣ.** Η ΟΙΚΟΔΟΜΗΣΗ
ΤΟΥ ΔΙΗΡΚΕΣΕ 120 ΕΤΗ.
ΚΙΟΝΕΣ ΑΦΙΕΡΩΘΗΚΑΝ
ΑΠΟ ΤΟΝ ΒΑΣΙΛΙΑ
ΚΡΟΙΣΟ ΤΗΣ ΛΥΔΙΑΣ.
ΠΥΡΠΟΛΗΘΗΚΕ ΤΟ ΕΤΟΣ
356 π.Χ.* ΑΠΟ ΤΟΝ
ΗΡΟΣΤΡΑΤΟ

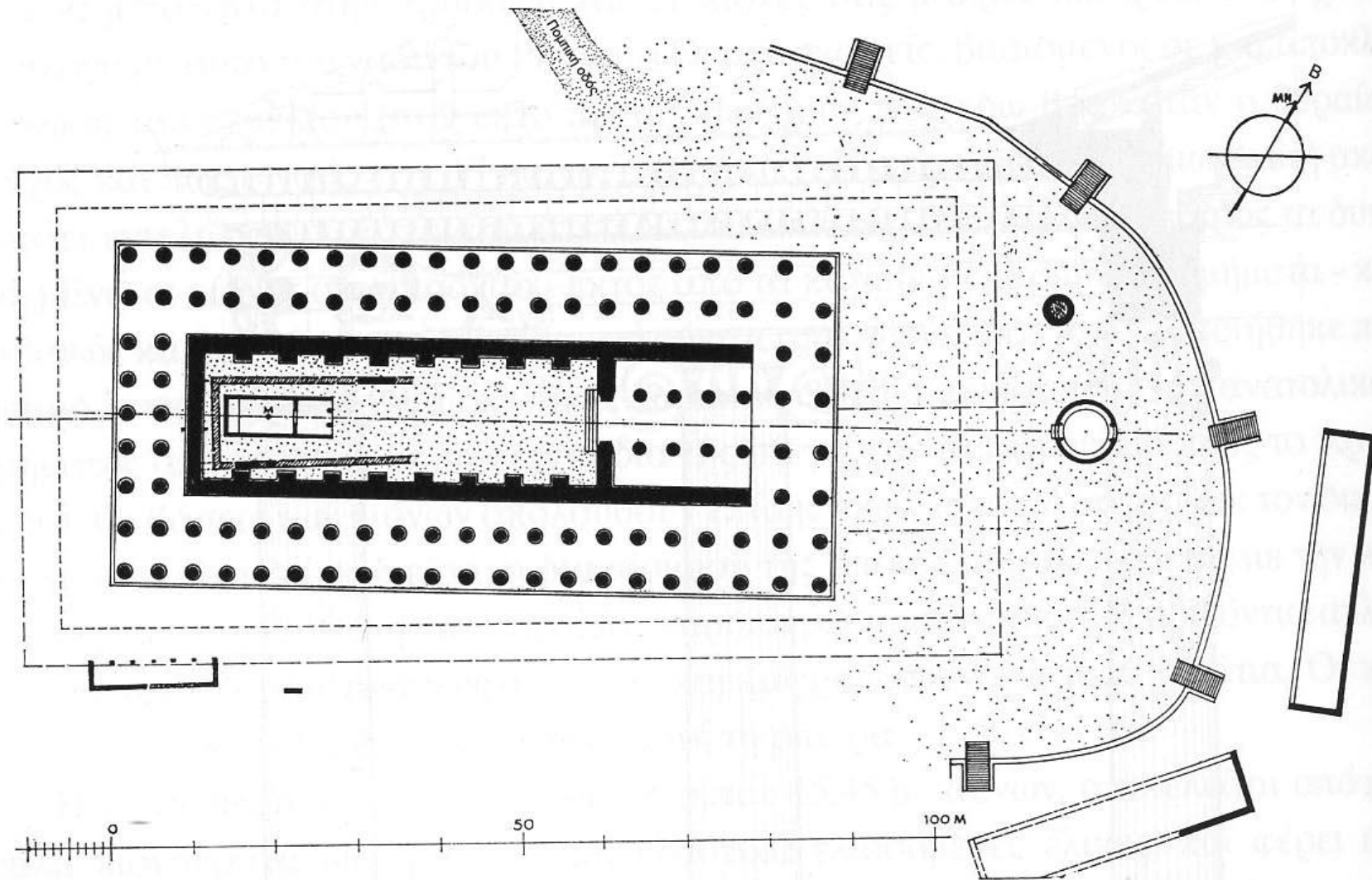

ΝΑΟΣ ΤΟΥ ΑΠΟΛΛΩΝΟΣ ΣΤΑ ΔΙΔΥΜΑ
ΜΙΛΗΤΟΥ (550 πΧ.)

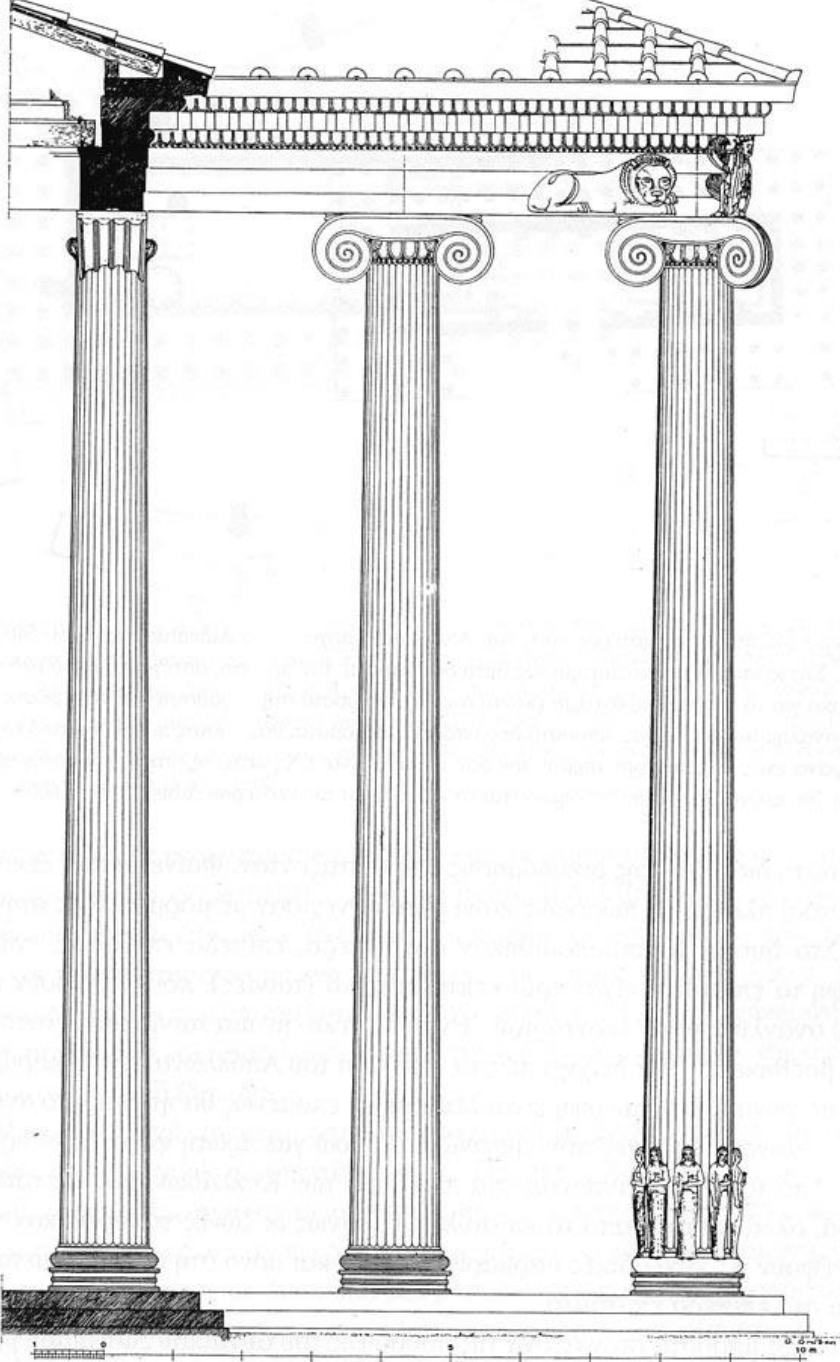

**ΚΙΟΝΕΣ ΑΠΟ ΠΩΡΟΛΙΘΟ
ΣΤΗ ΔΥΤΙΚΗ ΠΛΕΥΡΑ ΚΑΙ
ΜΑΡΜΑΡΙΝΟΙ ΣΤΗΝ
ΑΝΑΤΟΛΙΚΗ.**

**ΚΟΡΕΣ ΣΤΙΣ ΒΑΣΕΙΣ ΚΑΙ
ΑΝΑΓΛΥΦΟΙ ΛΕΟΝΤΕΣ ΚΑΙ
ΜΥΘΙΚΑ ΖΩΑ ΣΤΑ
ΕΠΙΣΤΥΛΙΑ.**



ΝΑΟΣ «ΤΗΣ ΔΗΜΗΤΡΑΣ» ΣΤΟ ΣΑΓΚΡΙ (ΓΥΡΟΥΛΑΞ)
ΝΑΕΟΥ (540-530 π.Χ).



