

Microeconomic Theory I

Optimal choice and demand

Stella Tsani

stsani@econ.uoa.gr

Lecture slides kindly offered by



Monetary Measures of Gains-to-Trade

- **You can buy as much gasoline as you wish at \$1 per gallon once you enter the gasoline market.**
- **Q: What is the most you would pay to enter the market?**

Monetary Measures of Gains-to-Trade

- **A: You would pay up to the dollar value of the gains-to-trade you would enjoy once in the market.**
- **How can such gains-to-trade be measured?**

Monetary Measures of Gains-to-Trade

- **Three such measures are:**
 - **Consumer's Surplus**
 - **Equivalent Variation, and**
 - **Compensating Variation.**
- **Only in one special circumstance do these three measures coincide.**

\$ Equivalent Utility Gains

- **Suppose gasoline can be bought only in lumps of one gallon.**
- **Use r_1 to denote the most a single consumer would pay for a 1st gallon -- call this her reservation price for the 1st gallon.**
- **r_1 is the dollar equivalent of the marginal utility of the 1st gallon.**

\$ Equivalent Utility Gains

- **Now that she has one gallon, use r_2 to denote the most she would pay for a 2nd gallon -- this is her reservation price for the 2nd gallon.**
- **r_2 is the dollar equivalent of the marginal utility of the 2nd gallon.**

\$ Equivalent Utility Gains

- **Generally, if she already has $n-1$ gallons of gasoline then r_n denotes the most she will pay for an n th gallon.**
- **r_n is the dollar equivalent of the marginal utility of the n th gallon.**

\$ Equivalent Utility Gains

- $r_1 + \dots + r_n$ will therefore be the dollar equivalent of the total change to utility from acquiring n gallons of gasoline at a price of \$0.
- So $r_1 + \dots + r_n - p_G n$ will be the dollar equivalent of the total change to utility from acquiring n gallons of gasoline at a price of $\$p_G$ each.

\$ Equivalent Utility Gains

- **A plot of $r_1, r_2, \dots, r_n, \dots$ against n is a reservation-price curve. This is not quite the same as the consumer's demand curve for gasoline.**

\$ Equivalent Utility Gains

(\$) Res. **Reservation Price Curve for Gasoline Values**

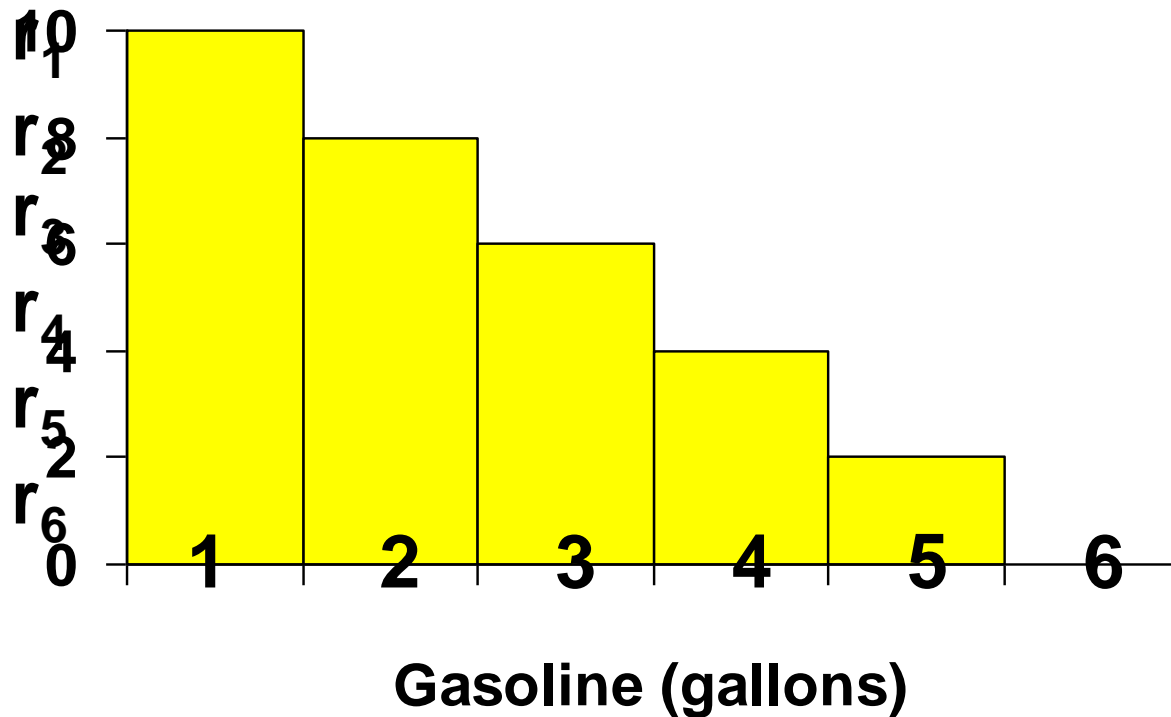

\$ Equivalent Utility Gains

- **What is the monetary value of our consumer's gain-to-trading in the gasoline market at a price of p_G ?**

\$ Equivalent Utility Gains

- **The dollar equivalent net utility gain for the 1st gallon is $\$(r_1 - p_G)$**
- **and is $\$(r_2 - p_G)$ for the 2nd gallon,**
- **and so on, so the dollar value of the gain-to-trade is**

$$\$(r_1 - p_G) + \$(r_2 - p_G) + \dots$$

for as long as $r_n - p_G > 0$.

\$ Equivalent Utility Gains

(\$) Res. **Reservation Price Curve for Gasoline Values**

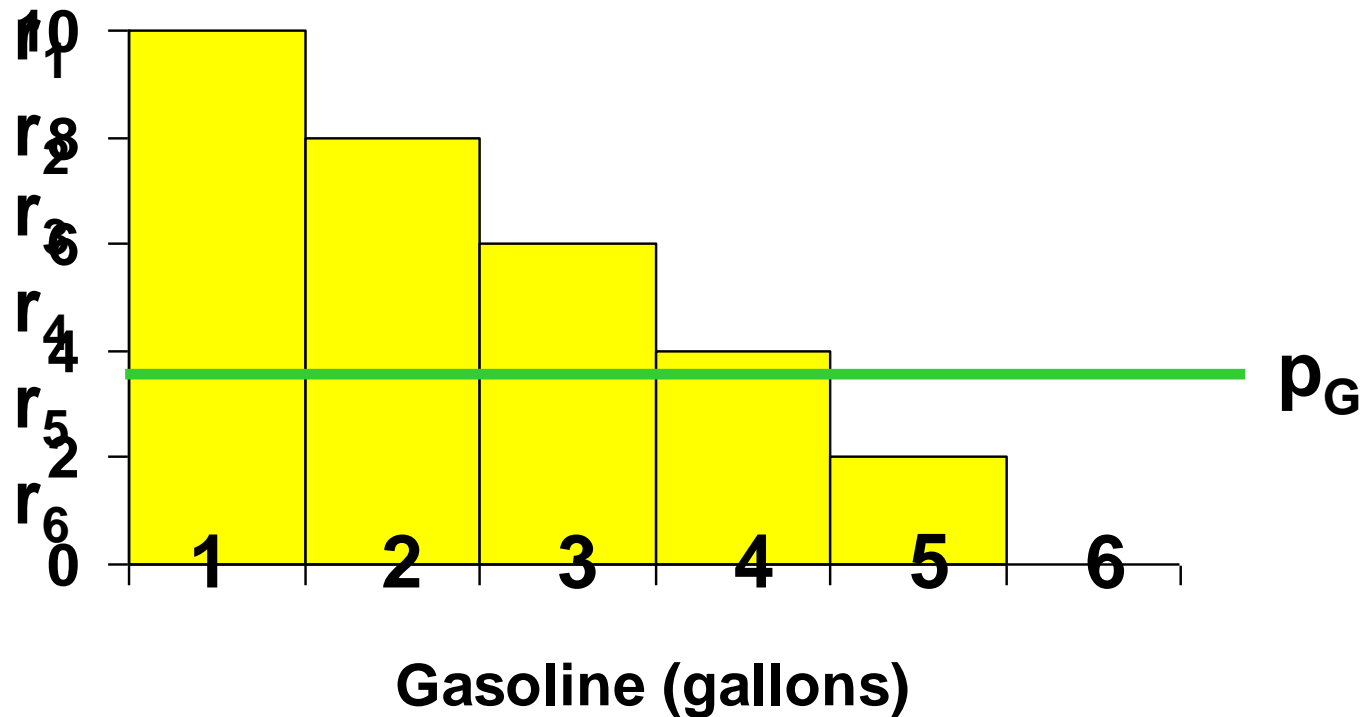

\$ Equivalent Utility Gains

(\$)
Res. Values
Reservation Price Curve for Gasoline

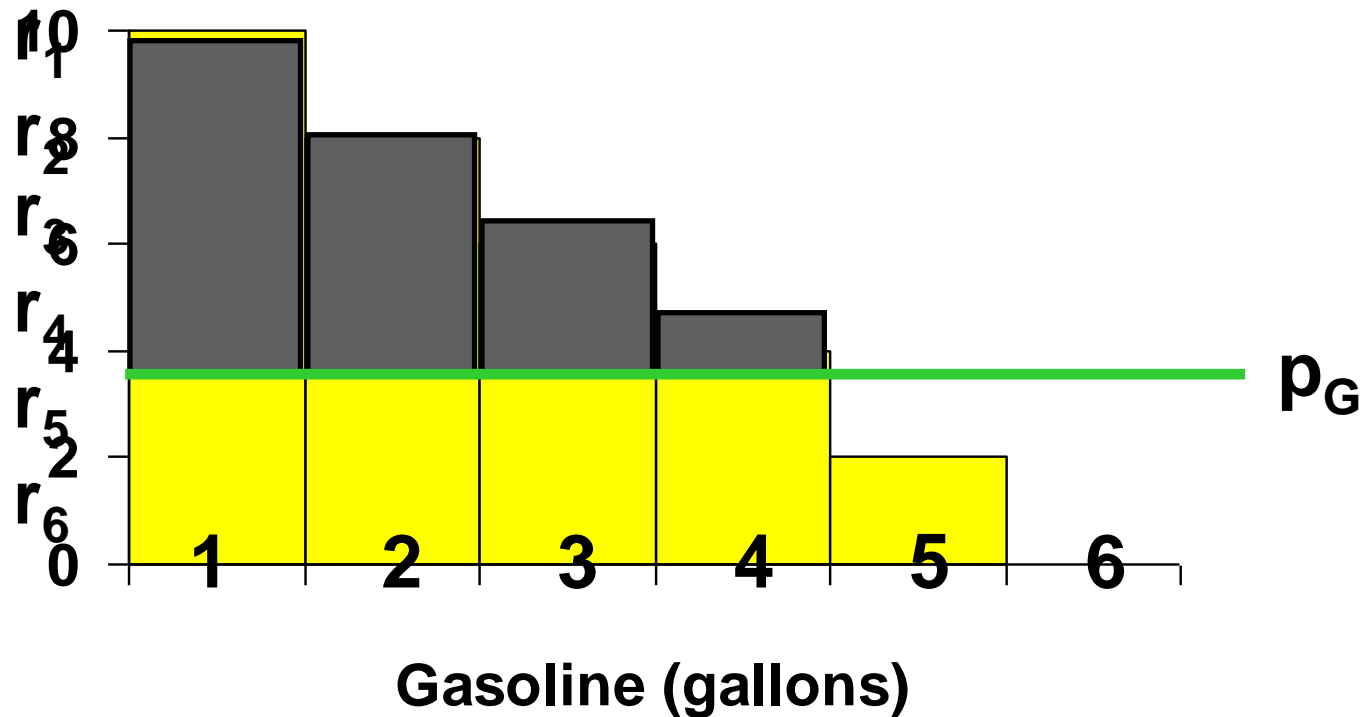

\$ Equivalent Utility Gains

(\$ Res. **Reservation Price Curve for Gasoline**
Values

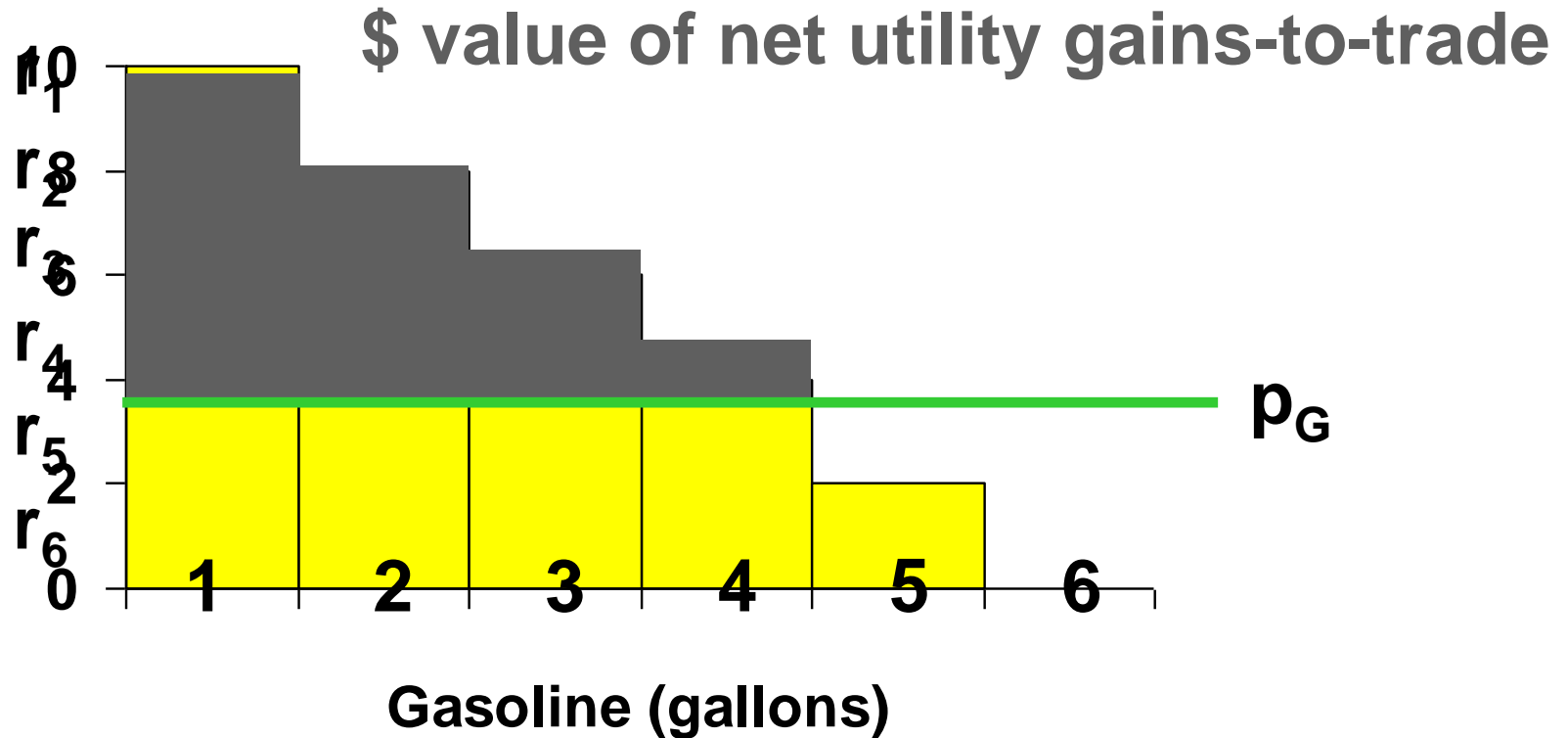

\$ Equivalent Utility Gains

- **Now suppose that gasoline is sold in half-gallon units.**
- **$r_1, r_2, \dots, r_n, \dots$ denote the consumer's reservation prices for successive half-gallons of gasoline.**
- **Our consumer's new reservation price curve is**

\$ Equivalent Utility Gains

(\$) Res. **Reservation Price Curve for Gasoline Values**

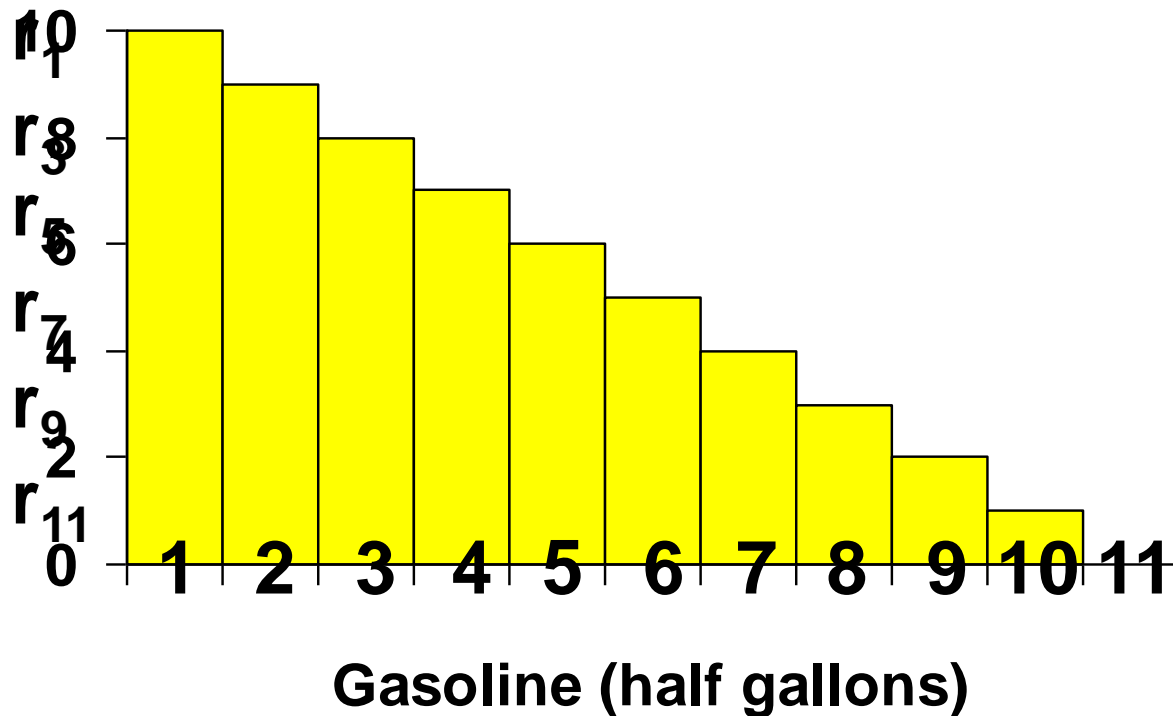

\$ Equivalent Utility Gains

(\$)
Res. Values
Reservation Price Curve for Gasoline

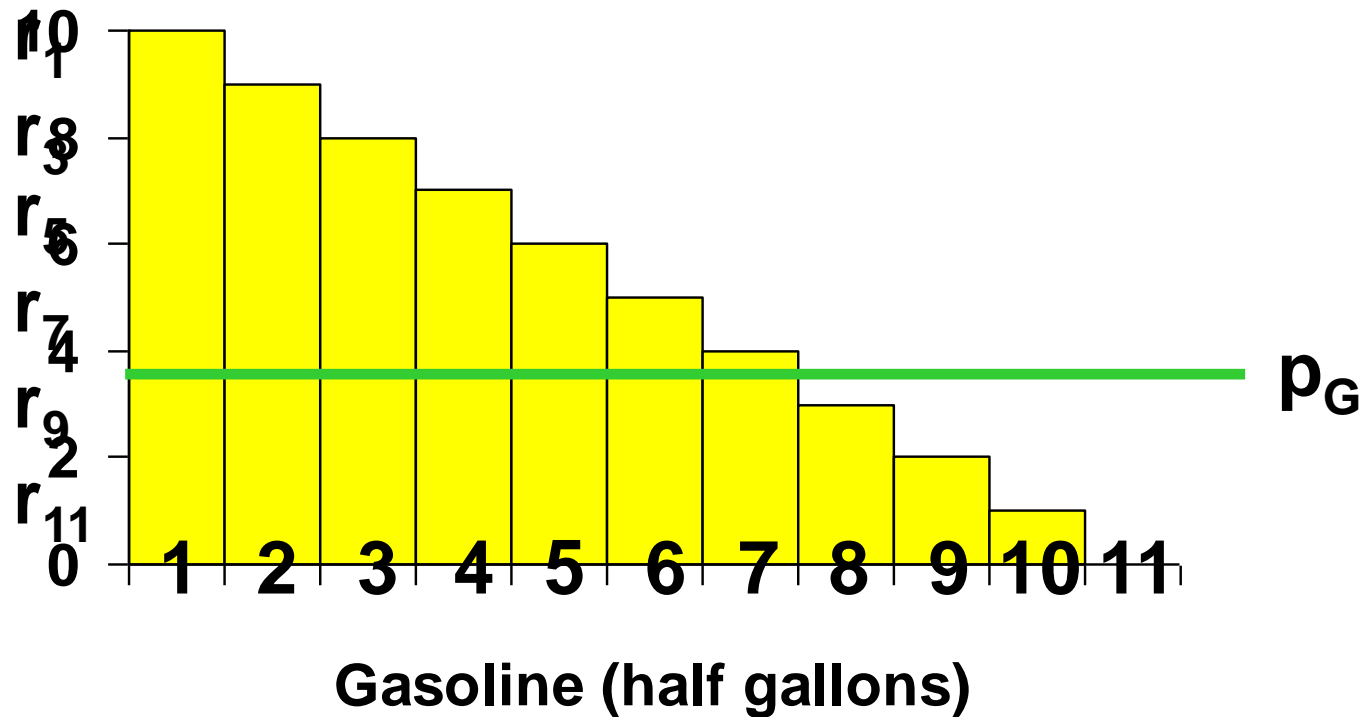

\$ Equivalent Utility Gains

(\$ Res. **Reservation Price Curve for Gasoline Values**

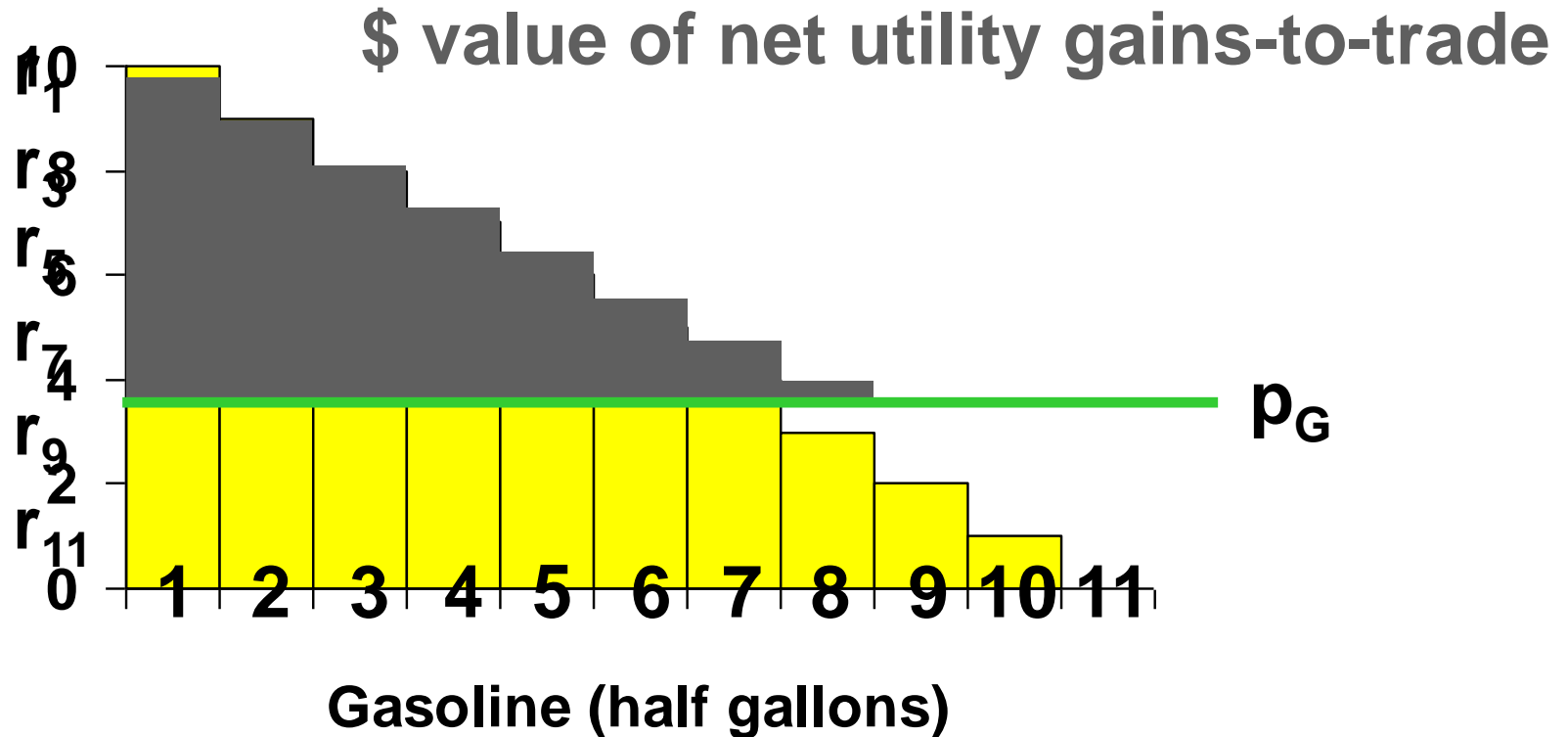

\$ Equivalent Utility Gains

- **And if gasoline is available in one-quarter gallon units ...**

\$ Equivalent Utility Gains

Reservation Price Curve for Gasoline

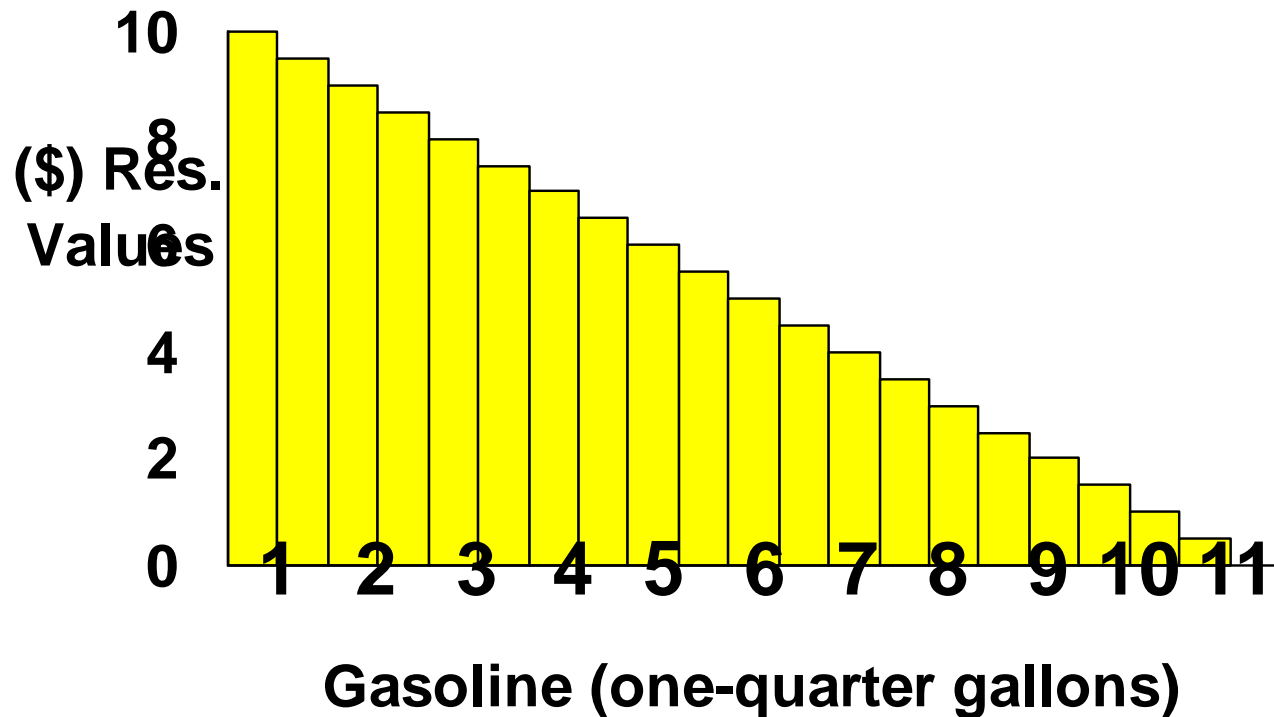

\$ Equivalent Utility Gains

Reservation Price Curve for Gasoline

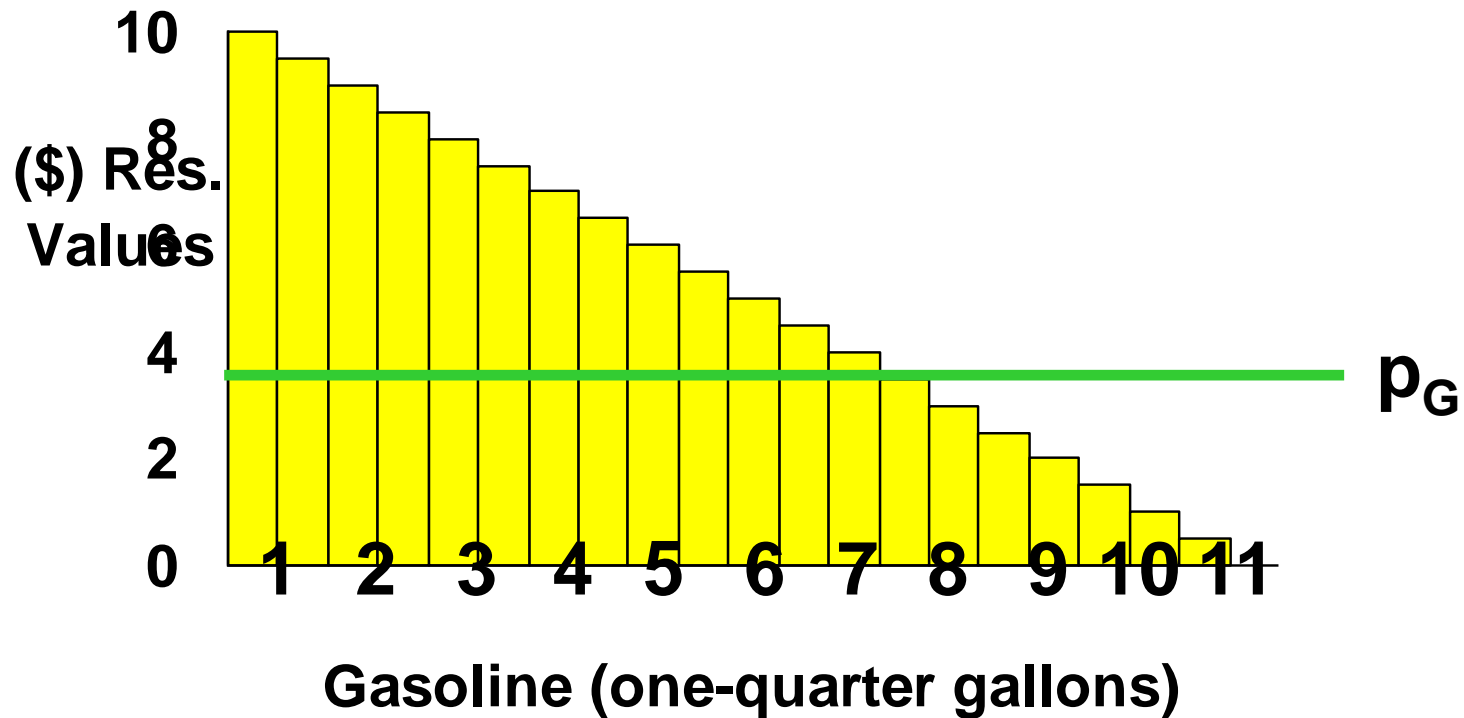

\$ Equivalent Utility Gains

Reservation Price Curve for Gasoline

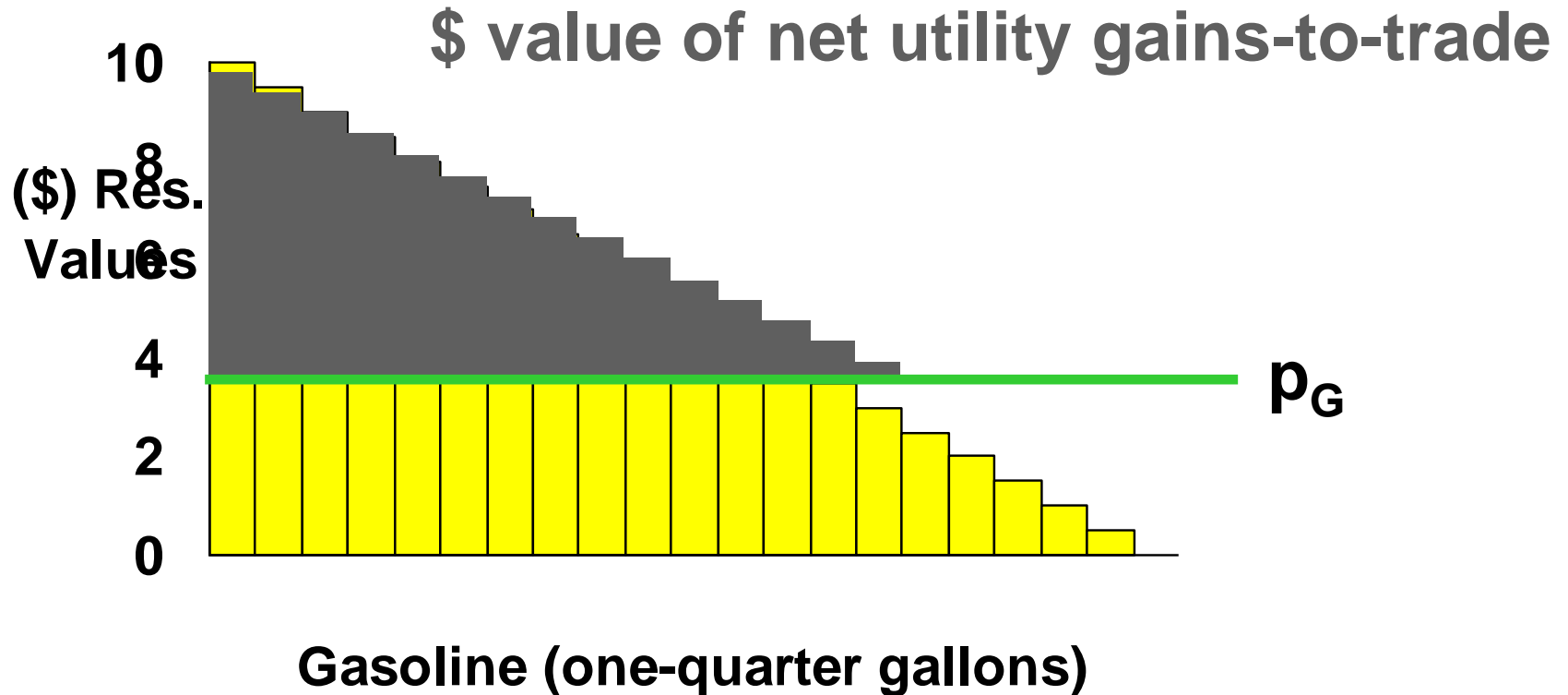

\$ Equivalent Utility Gains

- **Finally, if gasoline can be purchased in any quantity then ...**

\$ Equivalent Utility Gains

(\$) Res.
Prices

Reservation Price Curve for Gasoline

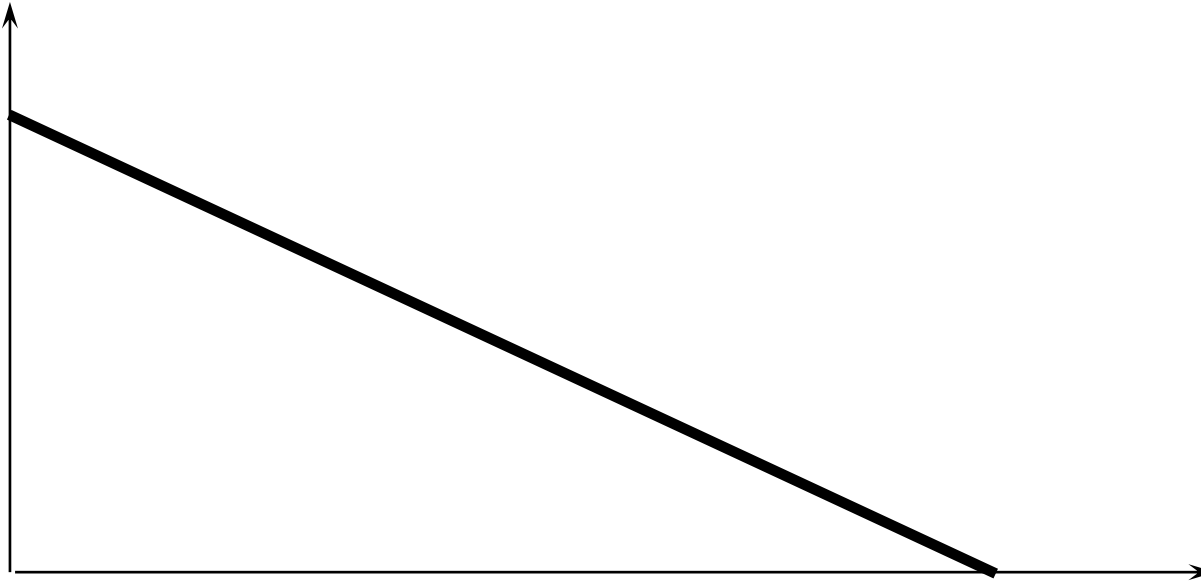

Gasoline

\$ Equivalent Utility Gains

(\$)
Res.
Prices

Reservation Price Curve for Gasoline

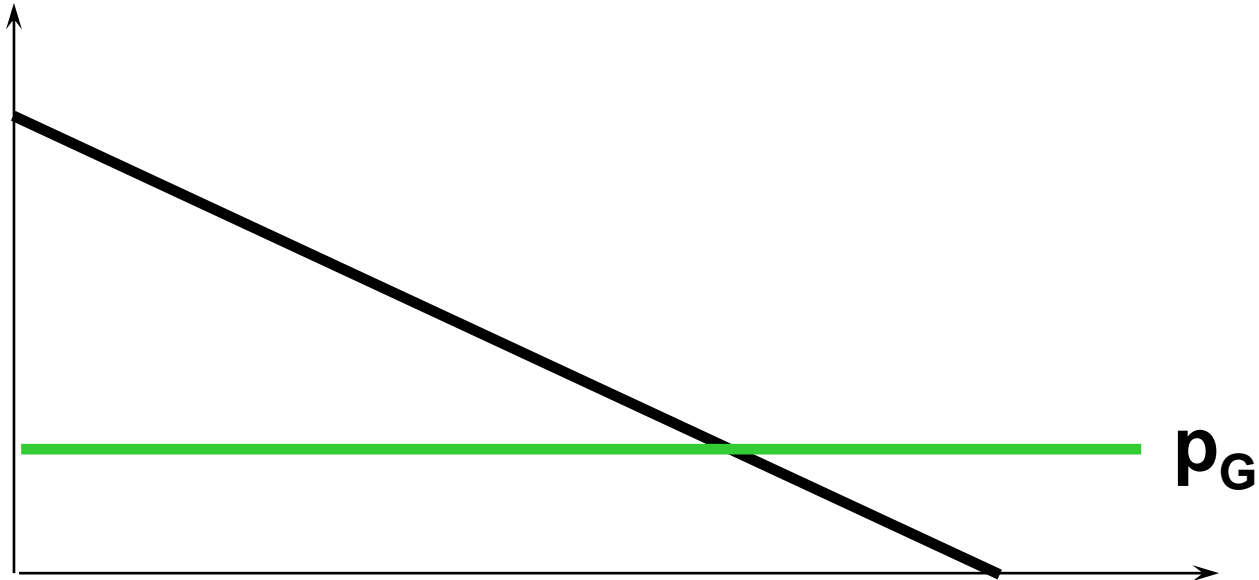

Gasoline

\$ Equivalent Utility Gains

(\$)
Res.
Prices

Reservation Price Curve for Gasoline

\$ value of net utility gains-to-trade

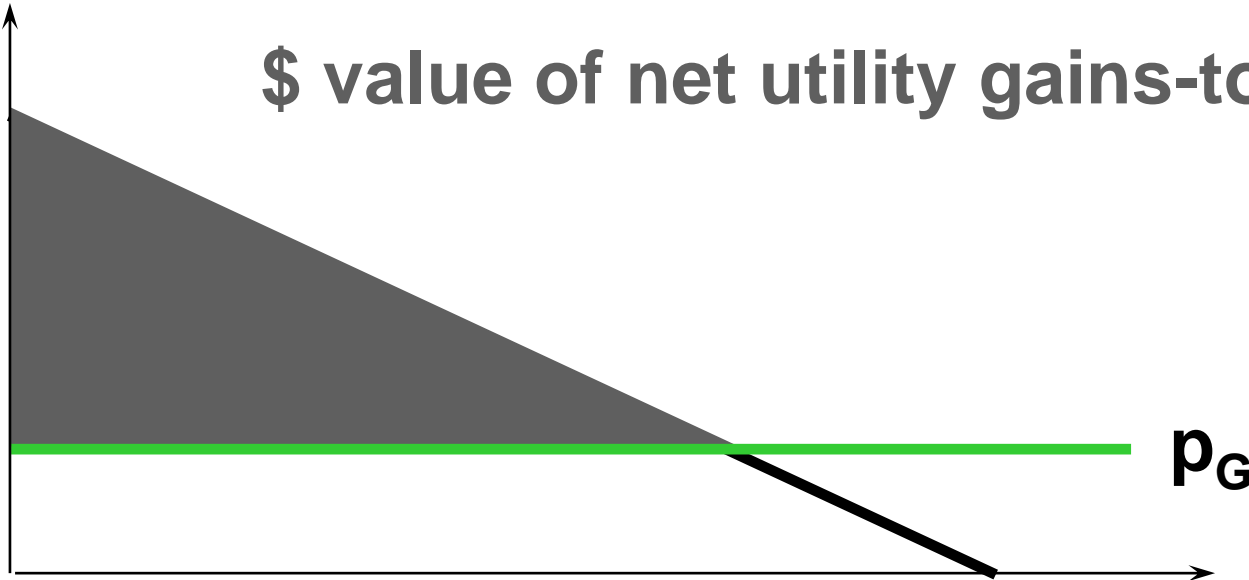

Gasoline

\$ Equivalent Utility Gains

- **Unfortunately, estimating a consumer's reservation-price curve is difficult,**
- **so, as an approximation, the reservation-price curve is replaced with the consumer's ordinary demand curve.**

Consumer's Surplus

- **A consumer's reservation-price curve is not quite the same as her ordinary demand curve. Why not?**
- **A reservation-price curve describes sequentially the values of successive single units of a commodity.**
- **An ordinary demand curve describes the most that would be paid for q units of a commodity purchased simultaneously.**

Consumer's Surplus

- **Approximating the net utility gain area under the reservation-price curve by the corresponding area under the ordinary demand curve gives the Consumer's Surplus measure of net utility gain.**

Consumer's Surplus

(\\$) Reservation price curve for gasoline
Ordinary demand curve for gasoline

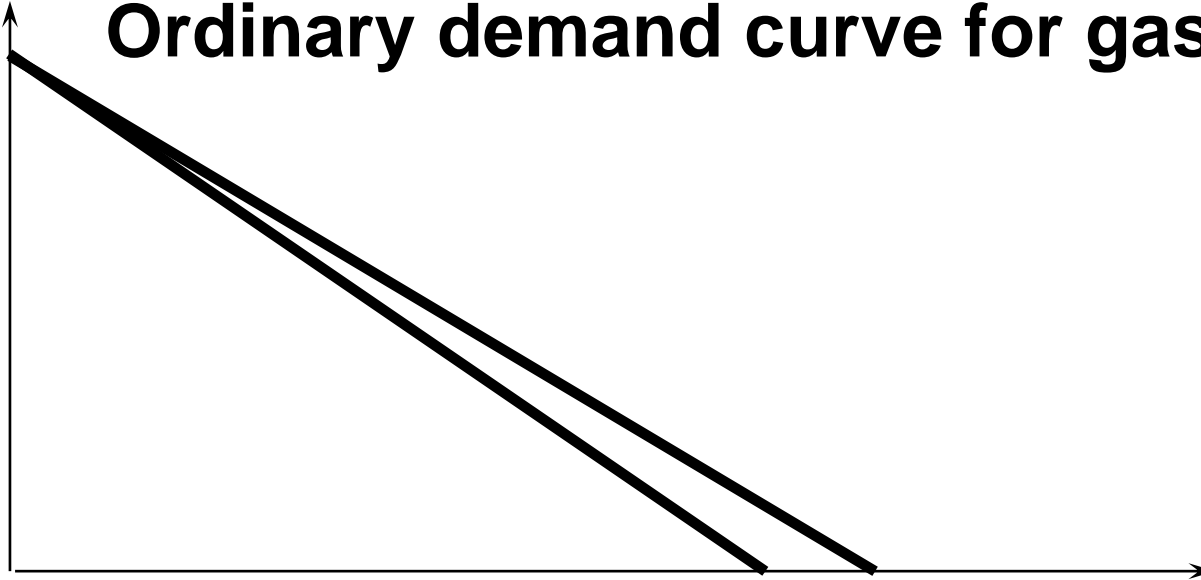

Gasoline

Consumer's Surplus

(**\$**) Reservation price curve for gasoline
Ordinary demand curve for gasoline

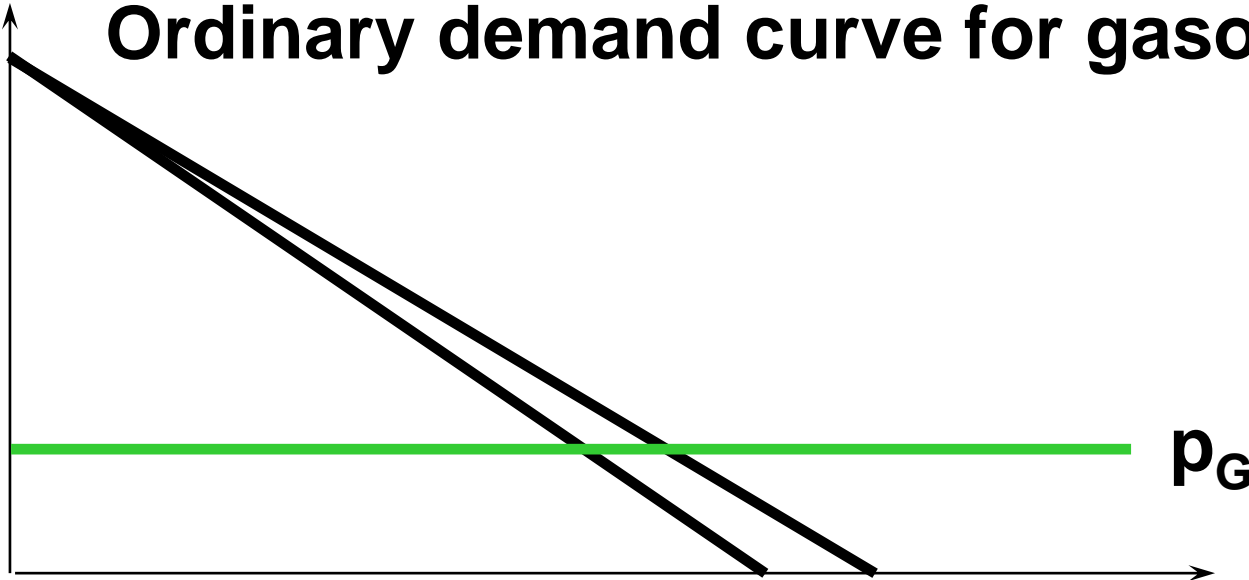

Gasoline

Consumer's Surplus

(**\$**) Reservation price curve for gasoline
Ordinary demand curve for gasoline
\$ value of net utility gains-to-trade

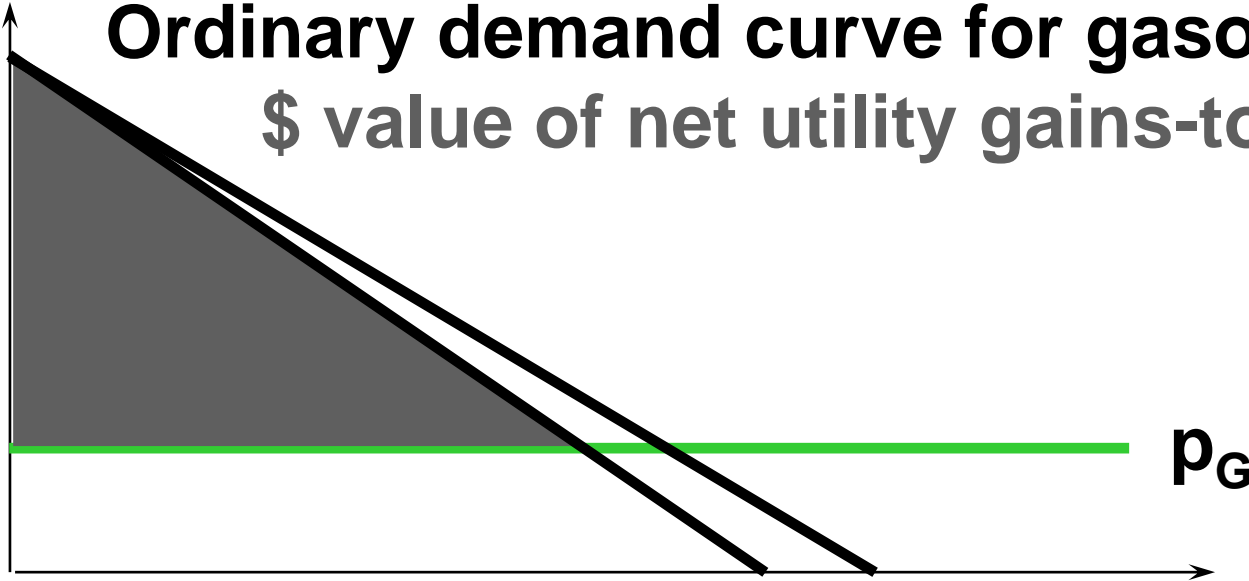

Gasoline

Consumer's Surplus

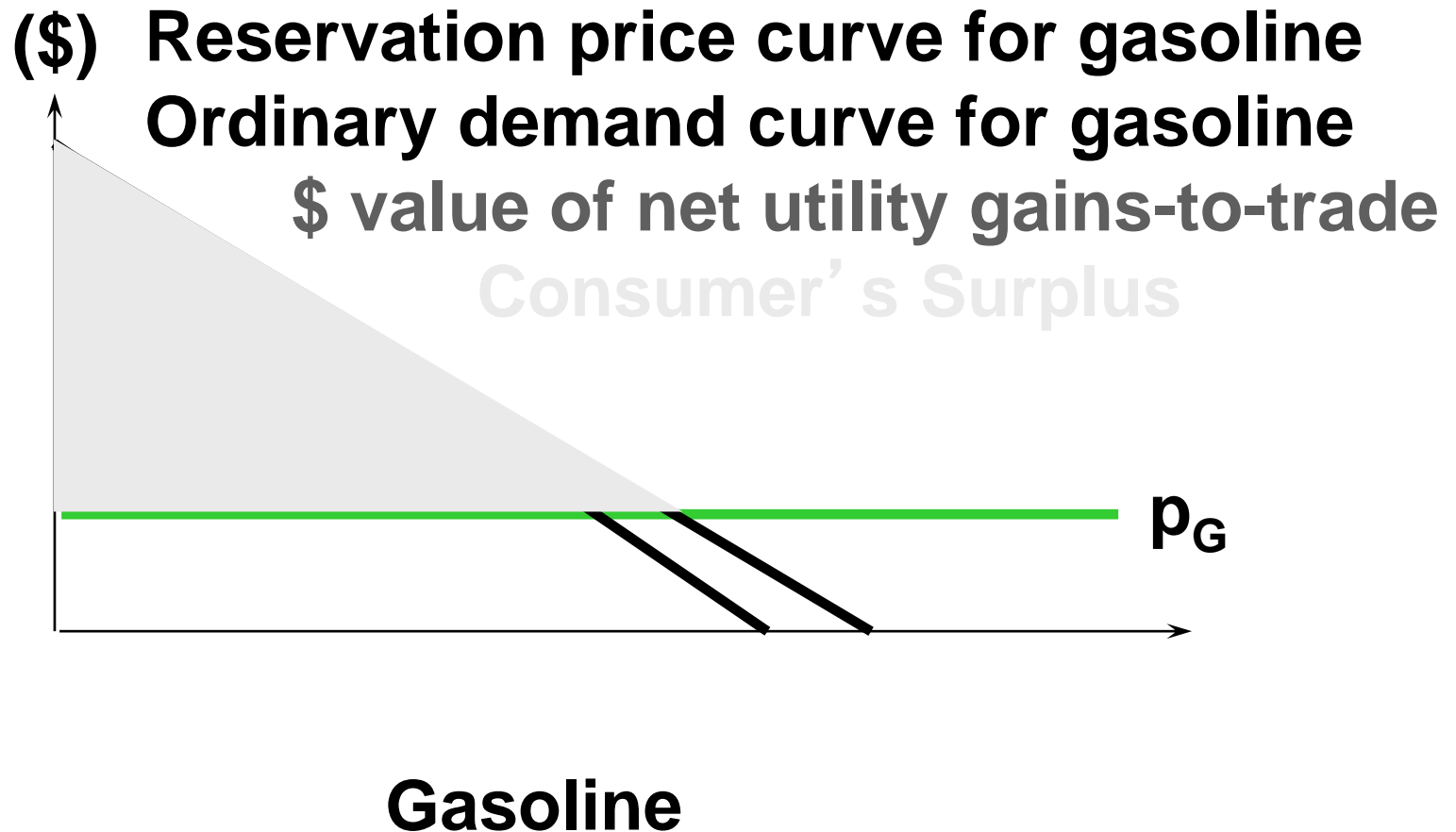

Consumer's Surplus

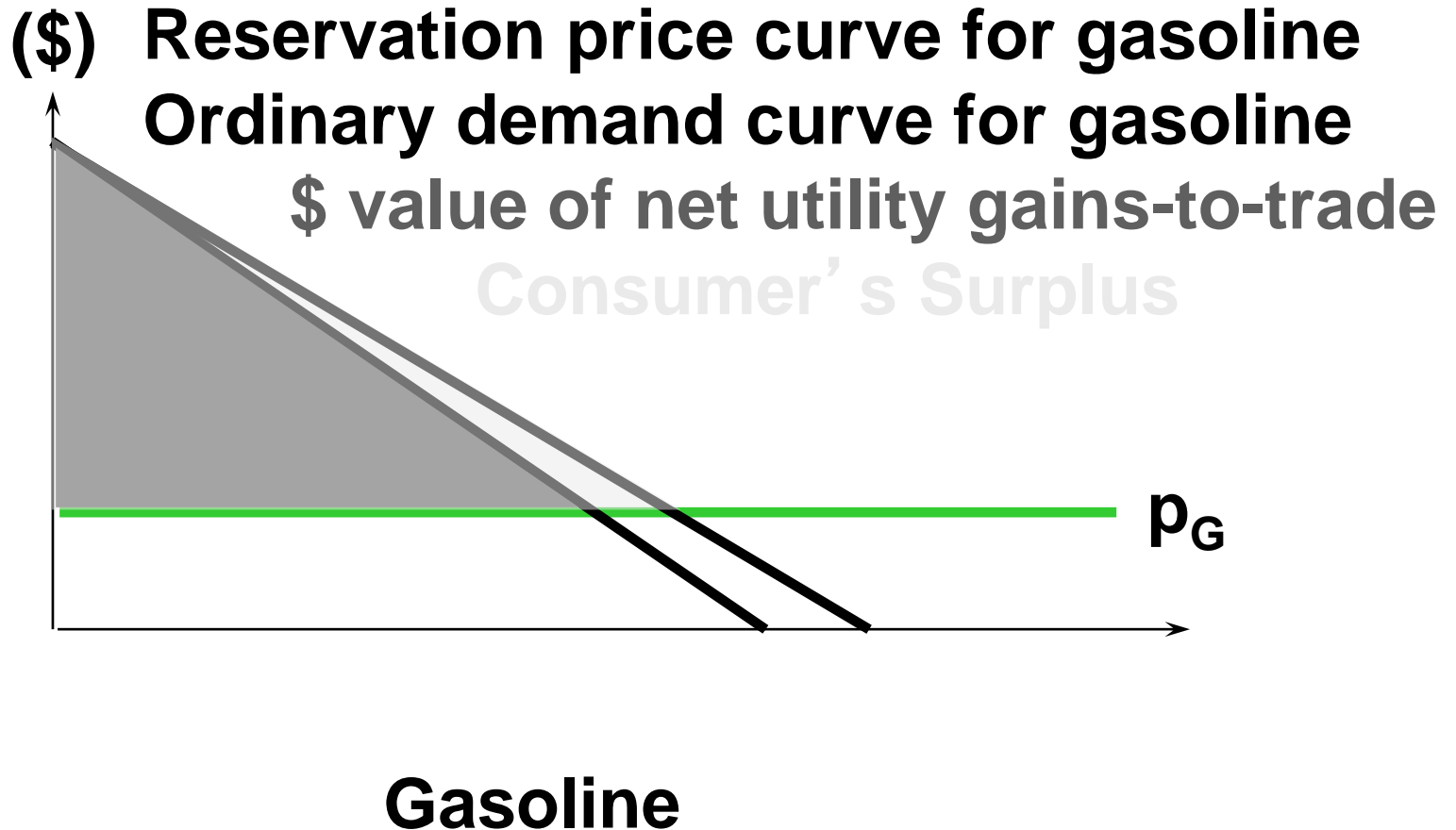

Consumer's Surplus

- **The difference between the consumer's reservation-price and ordinary demand curves is due to income effects.**
- **But, if the consumer's utility function is quasilinear in income then there are no income effects and Consumer's Surplus is an exact \$ measure of gains-to-trade.**

Consumer's Surplus

The consumer's utility function is quasilinear in x_2 .

$$U(x_1, x_2) = v(x_1) + x_2$$

Take $p_2 = 1$. Then the consumer's choice problem is to maximize

$$U(x_1, x_2) = v(x_1) + x_2$$

subject to

$$p_1 x_1 + x_2 = m.$$

Consumer's Surplus

The consumer's utility function is quasilinear in x_2 .

$$U(x_1, x_2) = v(x_1) + x_2$$

Take $p_2 = 1$. Then the consumer's choice problem is to maximize

$$U(x_1, x_2) = v(x_1) + x_2$$

subject to

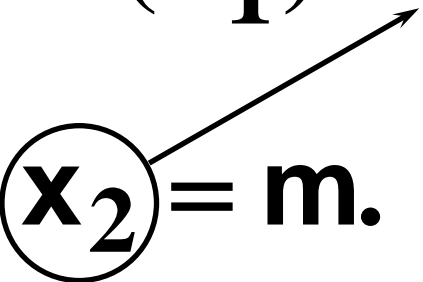
$$p_1 x_1 + x_2 = m.$$

Consumer's Surplus

That is, choose x_1 to maximize

$$v(x_1) + m - p_1 x_1.$$

The first-order condition is

$$v'(x_1) - p_1 = 0$$

That is, $p_1 = v'(x_1)$.

This is the equation of the consumer's ordinary demand for commodity 1.

Consumer's Surplus

Ordinary demand curve, $p_1 = v'(x_1)$

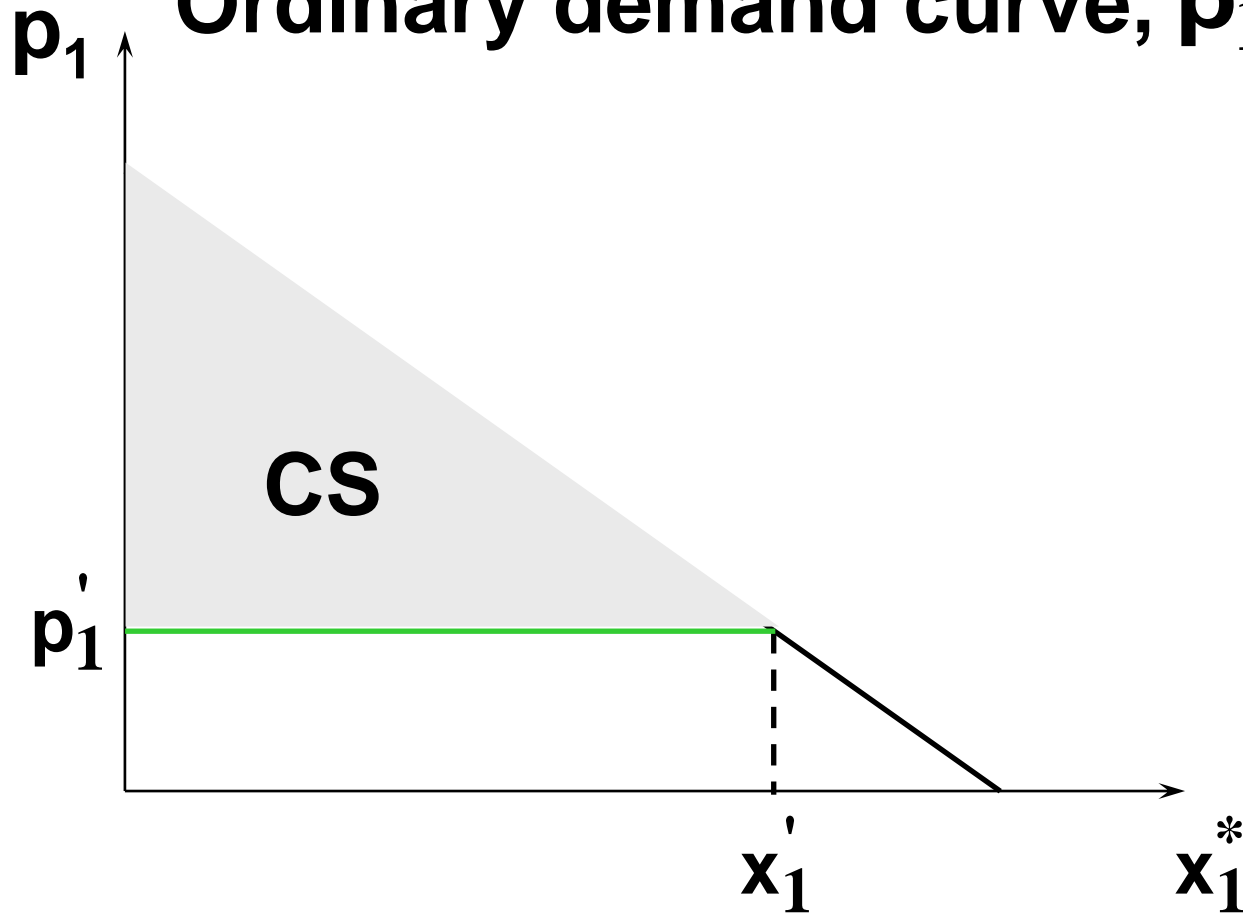

Consumer's Surplus

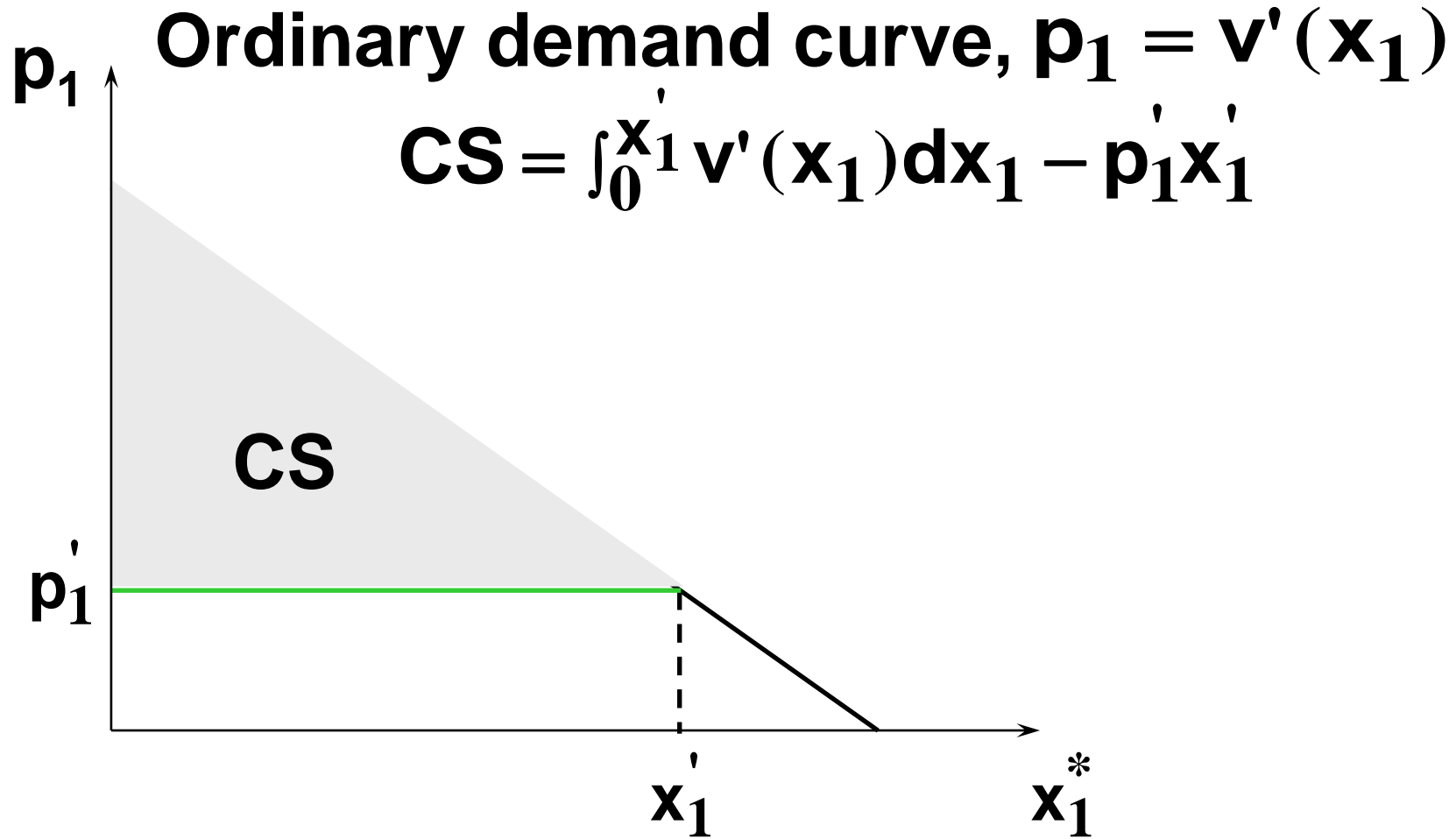

Consumer's Surplus

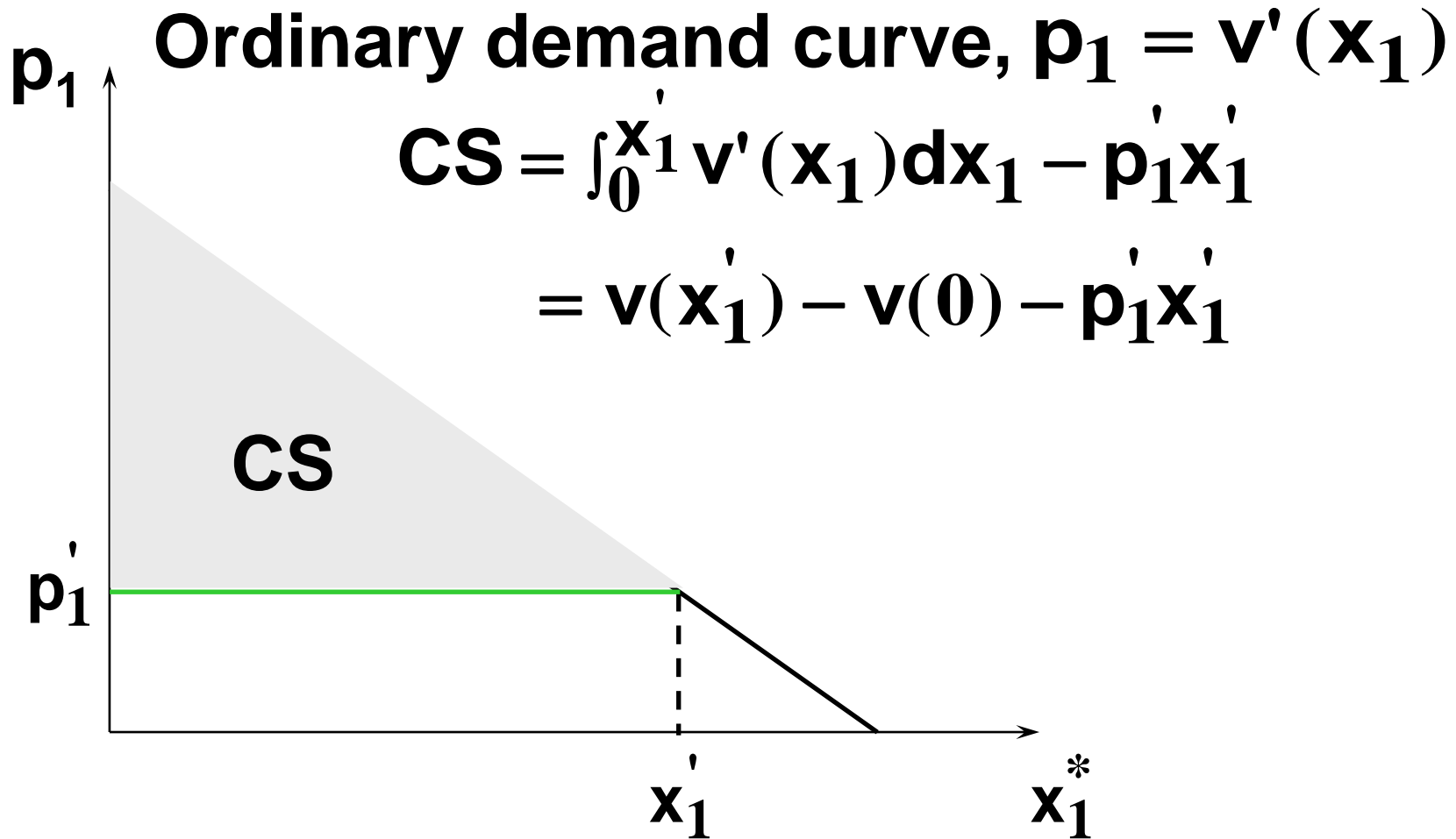

Consumer's Surplus

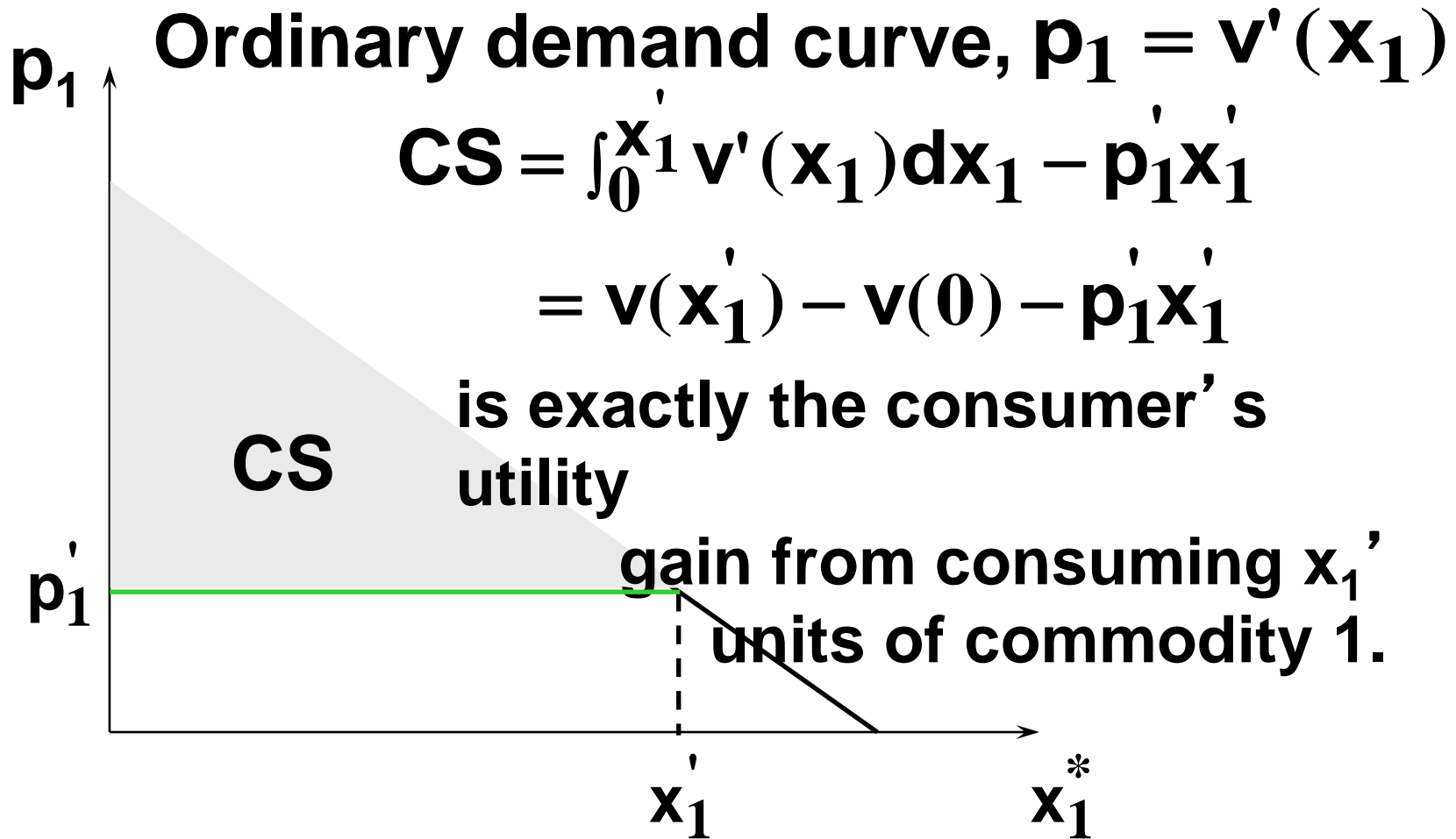

Consumer's Surplus

- **Consumer's Surplus is an exact dollar measure of utility gained from consuming commodity 1 when the consumer's utility function is quasilinear in commodity 2.**
- **Otherwise Consumer's Surplus is an approximation.**

Consumer's Surplus

- **The change to a consumer's total utility due to a change to p_1 is approximately the change in her Consumer's Surplus.**

Consumer's Surplus

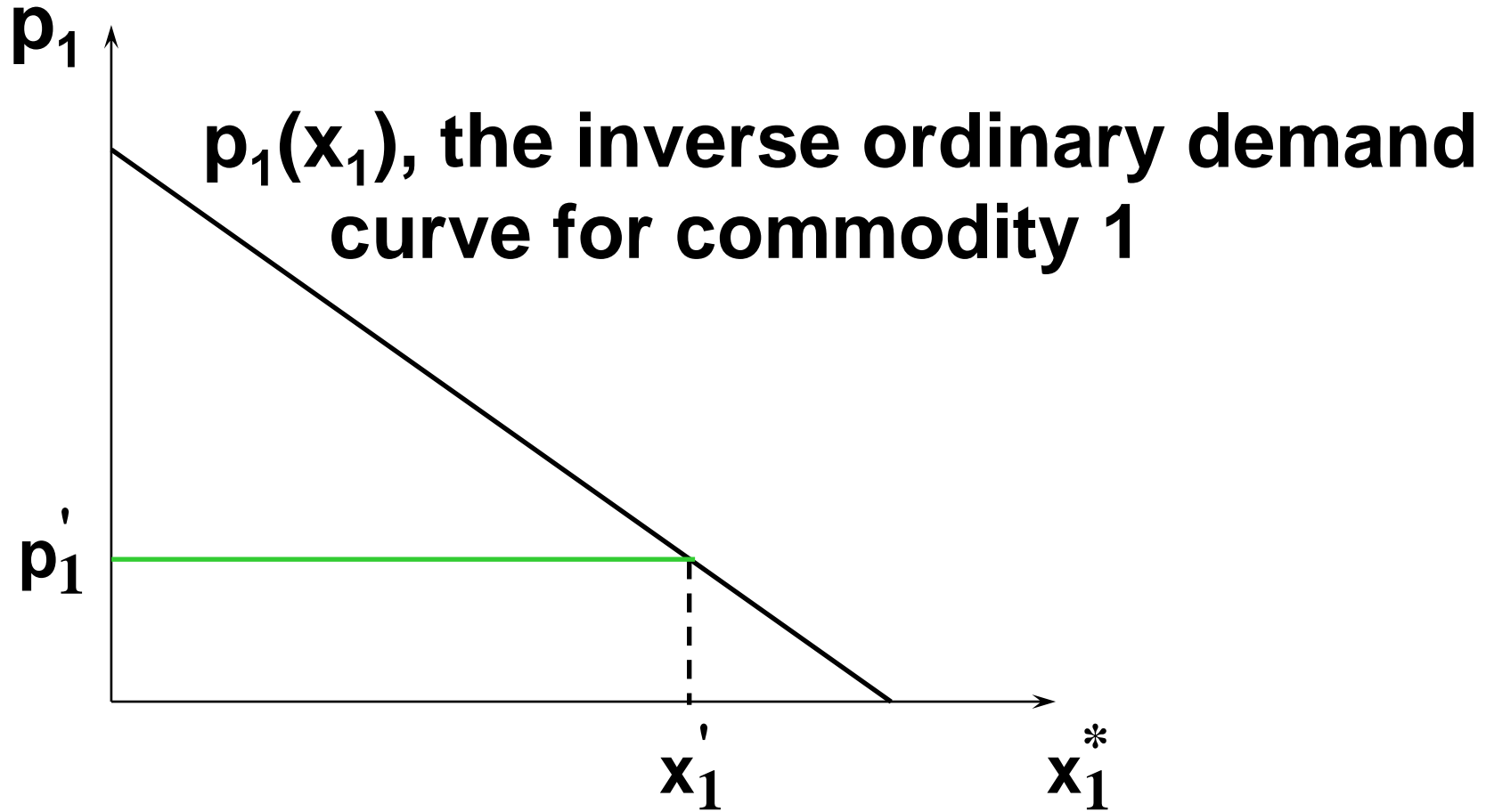

Consumer's Surplus

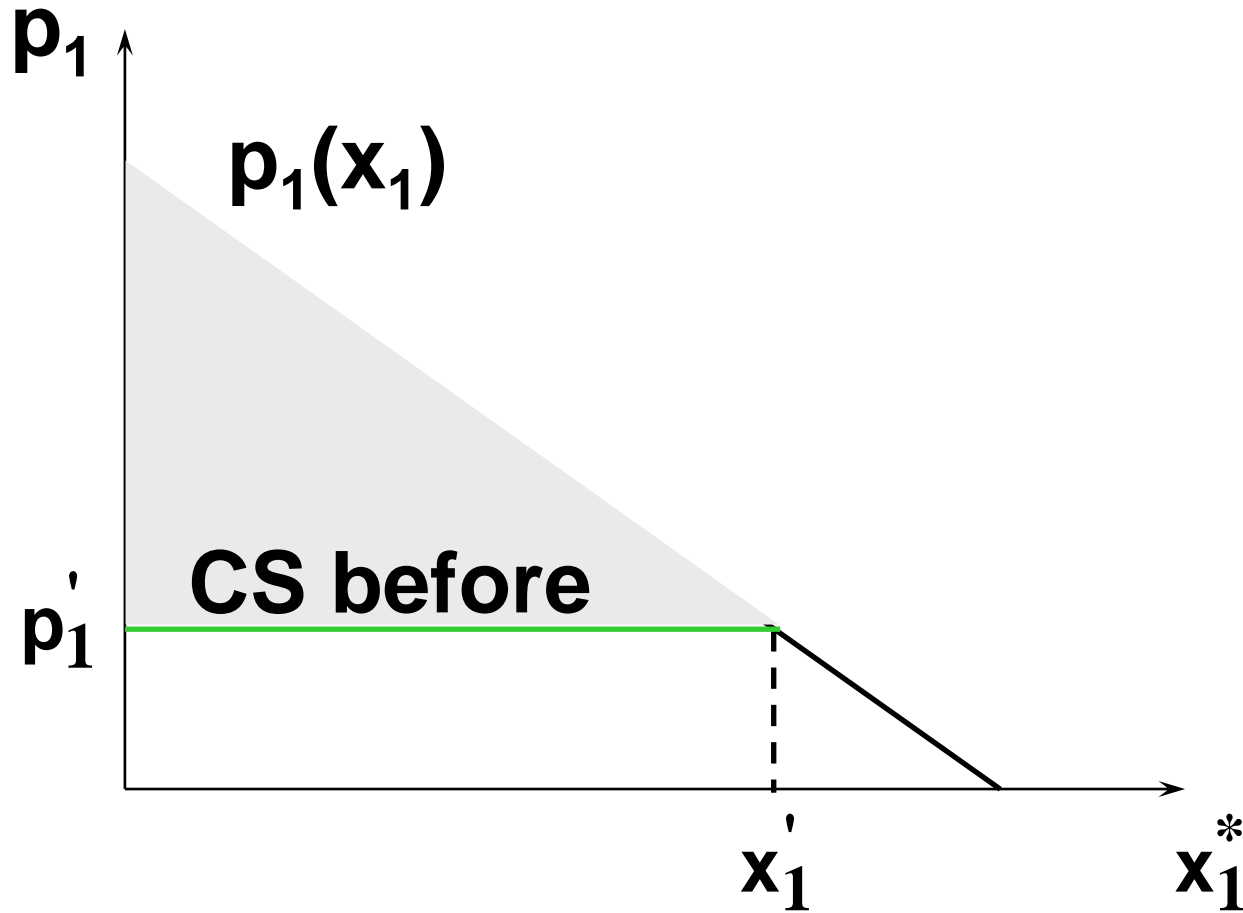

Consumer's Surplus

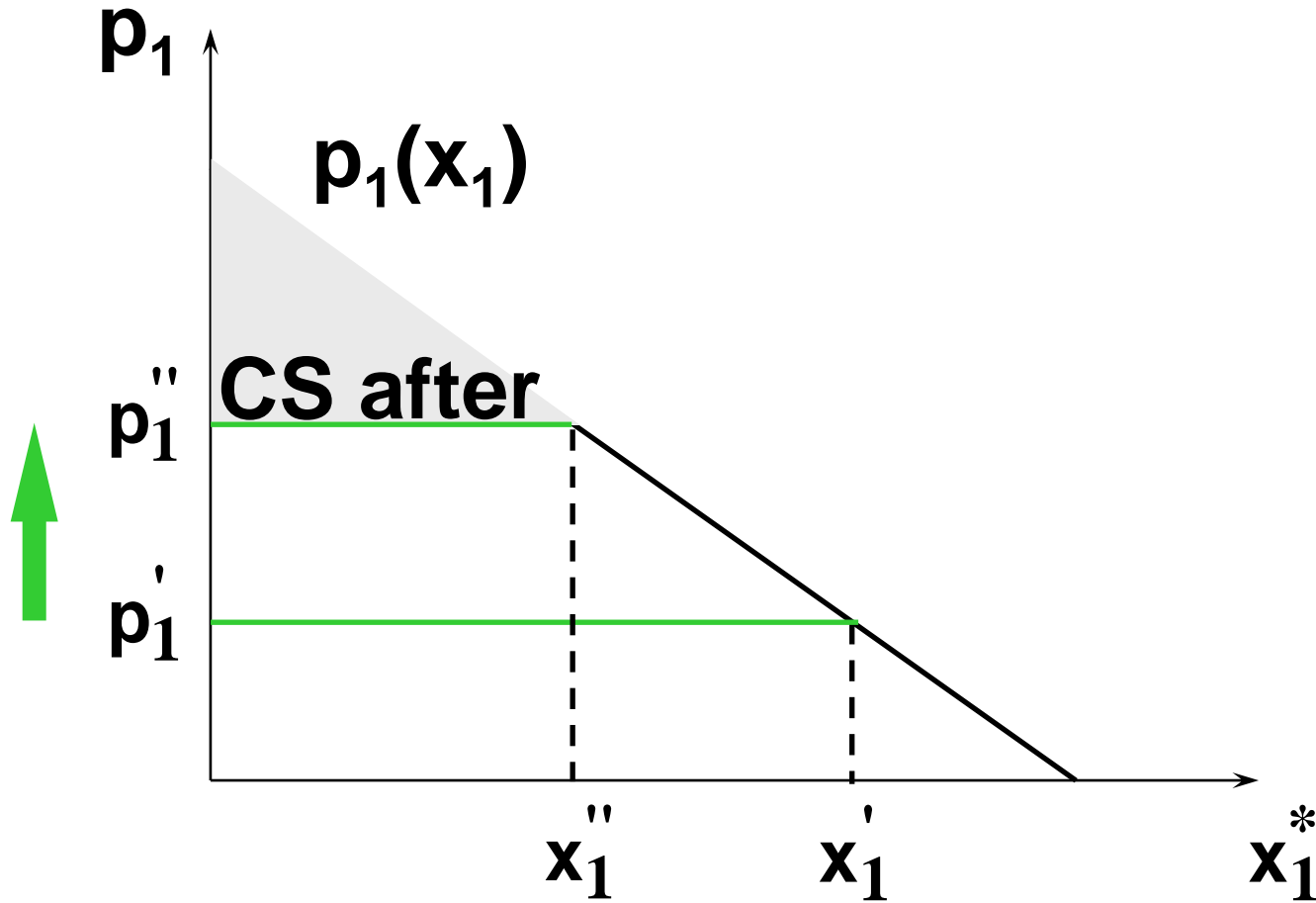

Consumer's Surplus

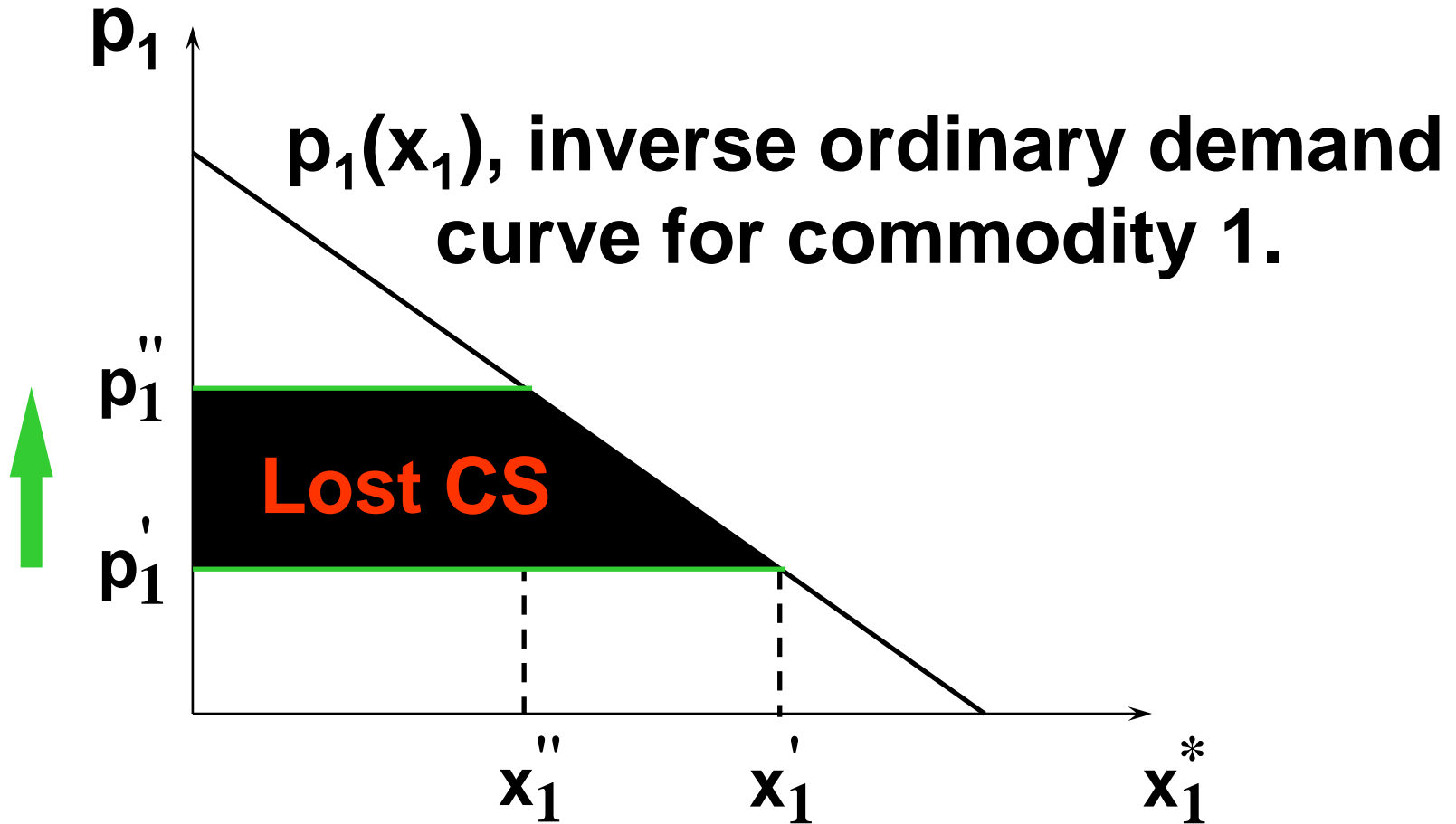

Consumer's Surplus

$x_1^*(p_1)$, the consumer's ordinary demand curve for commodity 1.

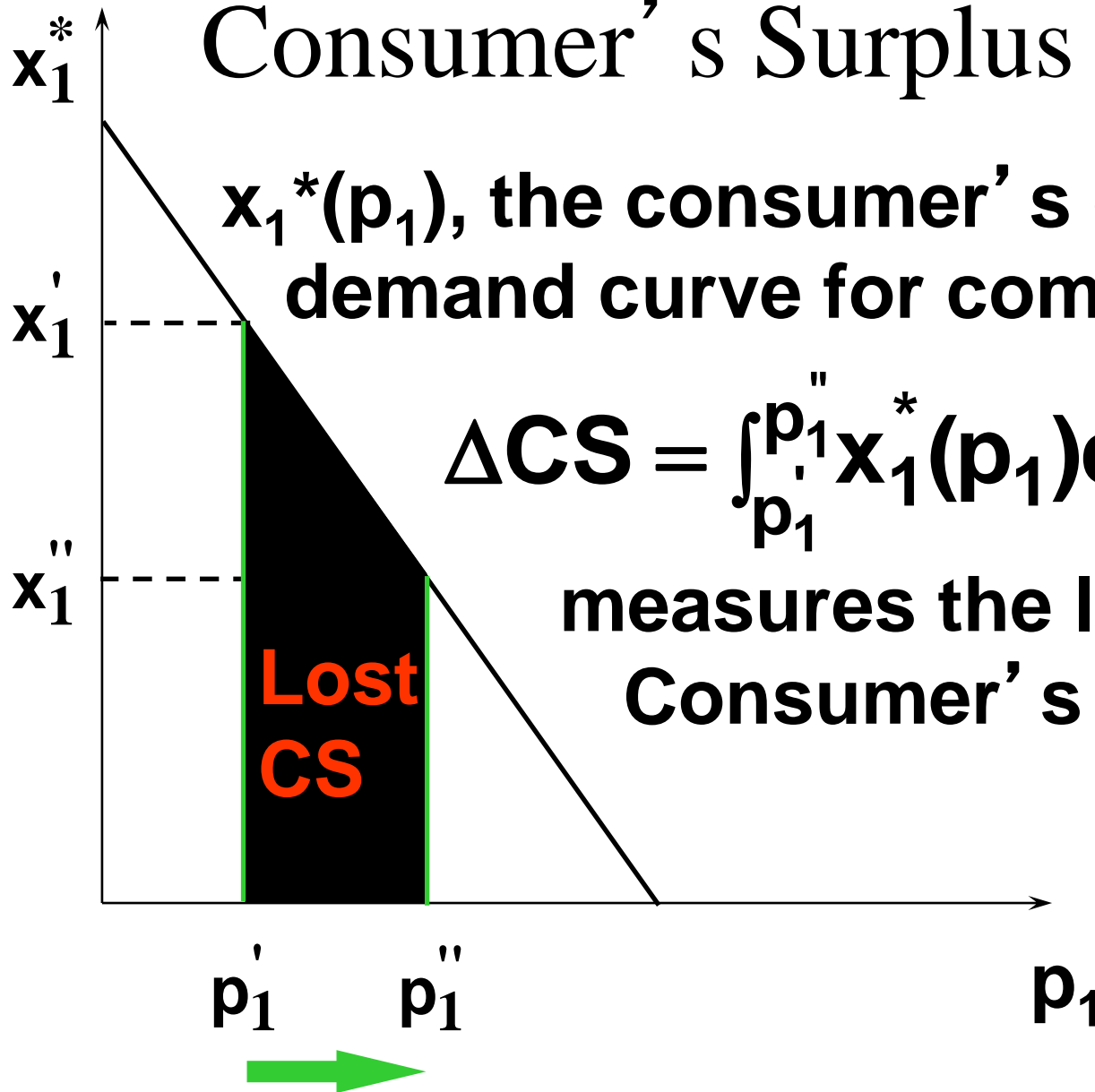

Compensating Variation and Equivalent Variation

- **Two additional dollar measures of the total utility change caused by a price change are Compensating Variation and Equivalent Variation.**

Compensating Variation

- **p_1 rises.**
- **Q: What is the least extra income that, at the new prices, just restores the consumer's original utility level?**

Compensating Variation

- **p_1 rises.**
- **Q: What is the least extra income that, at the new prices, just restores the consumer's original utility level?**
- **A: The Compensating Variation.**

Compensating Variation

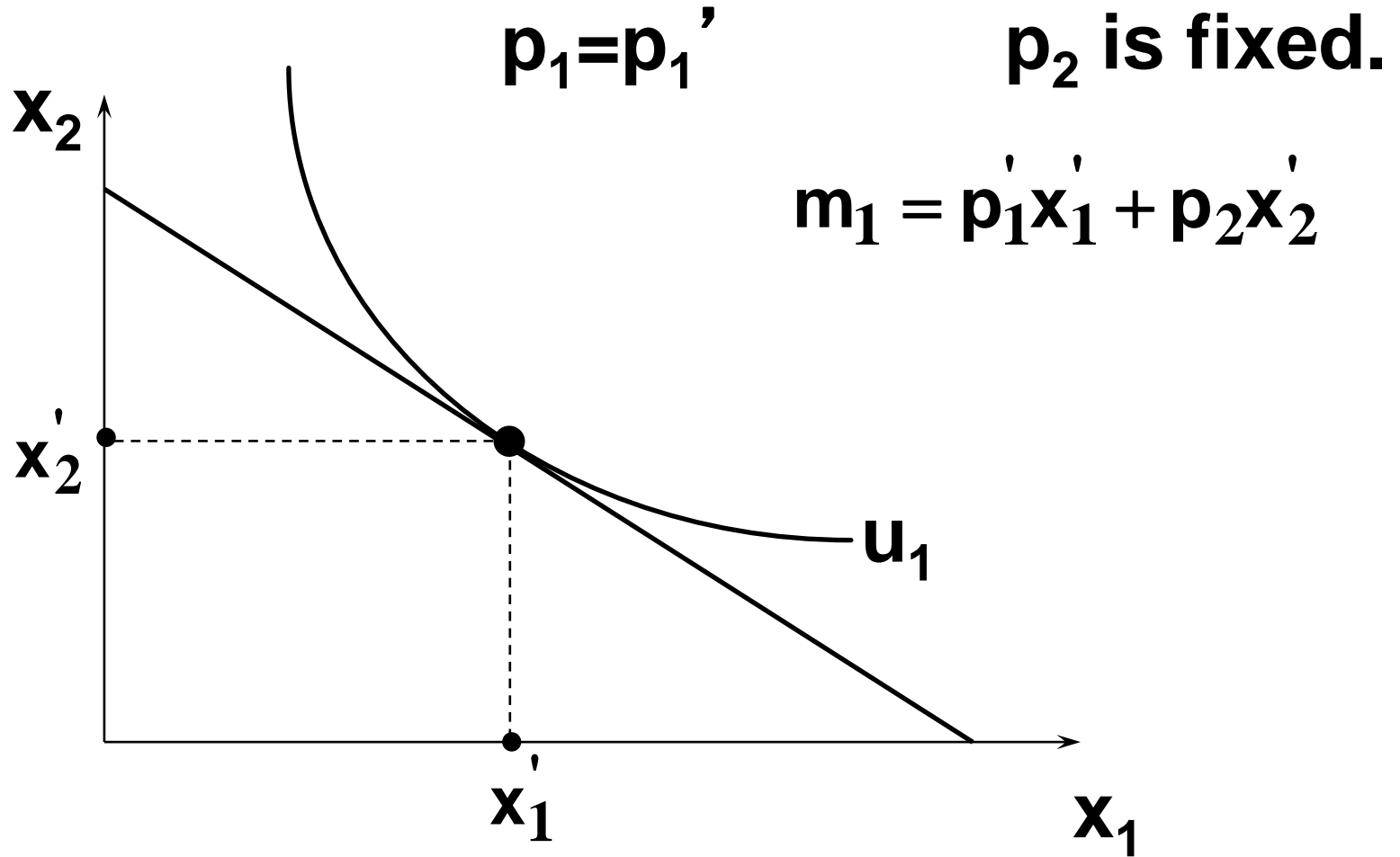

Compensating Variation

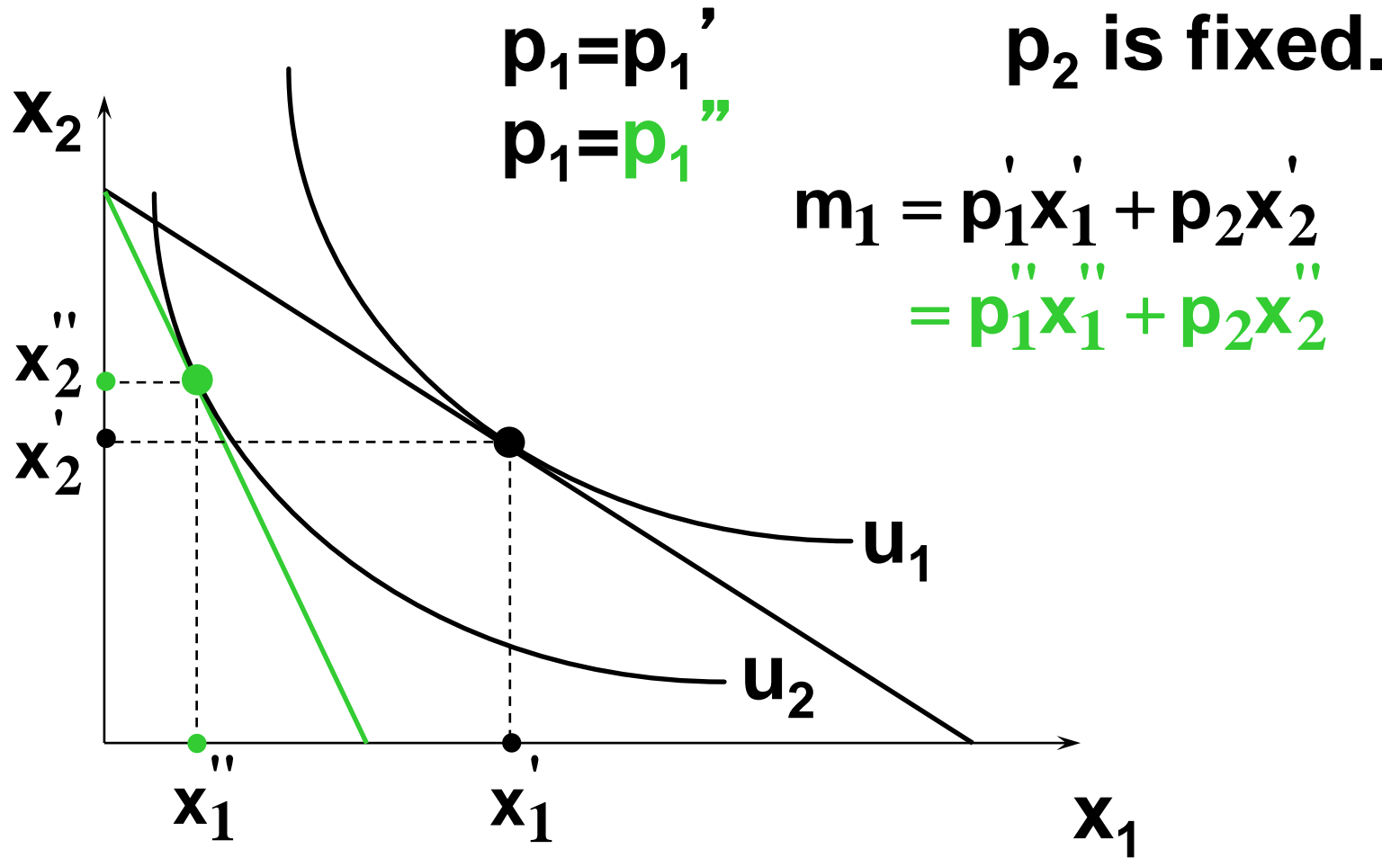

Compensating Variation

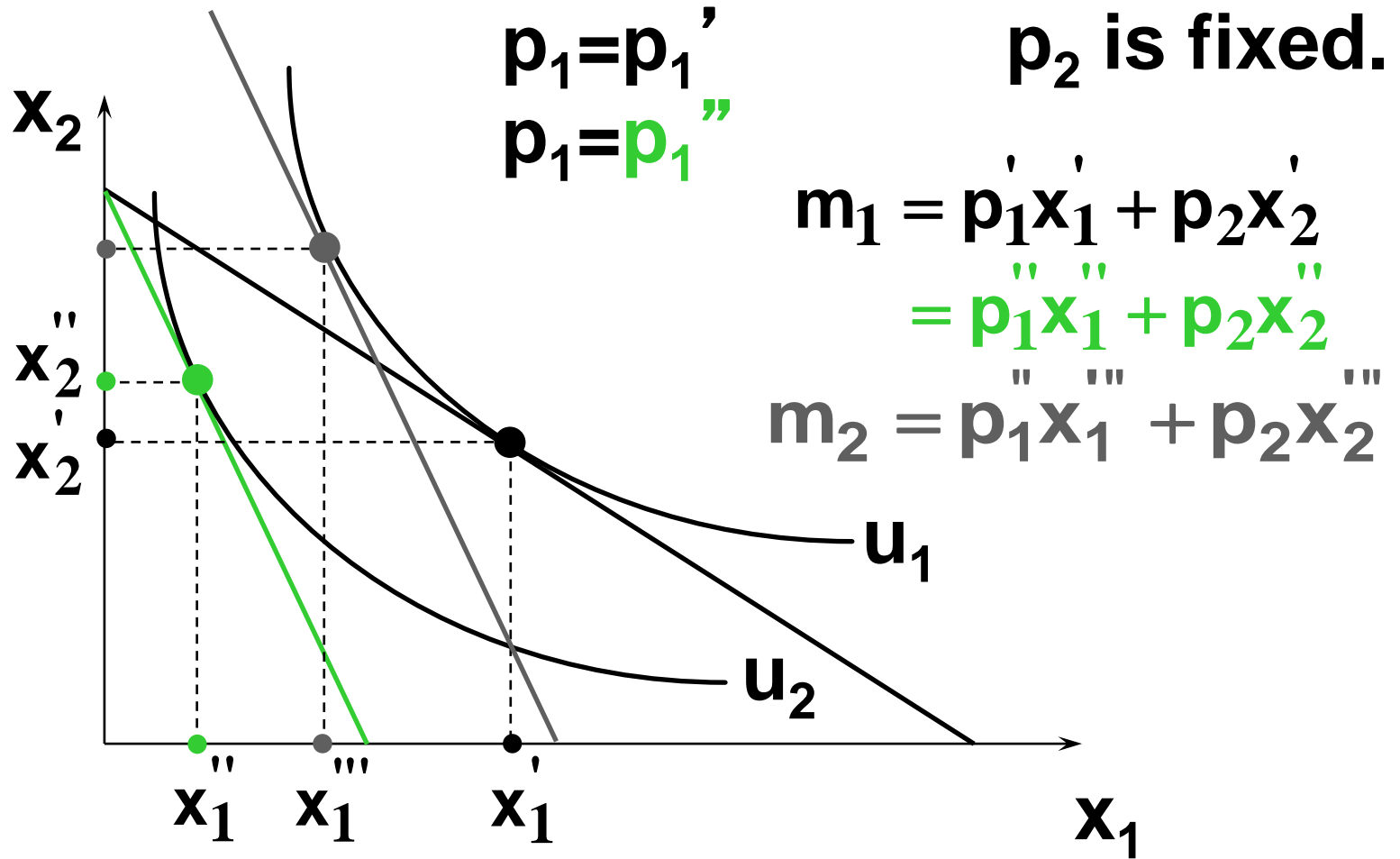

Compensating Variation

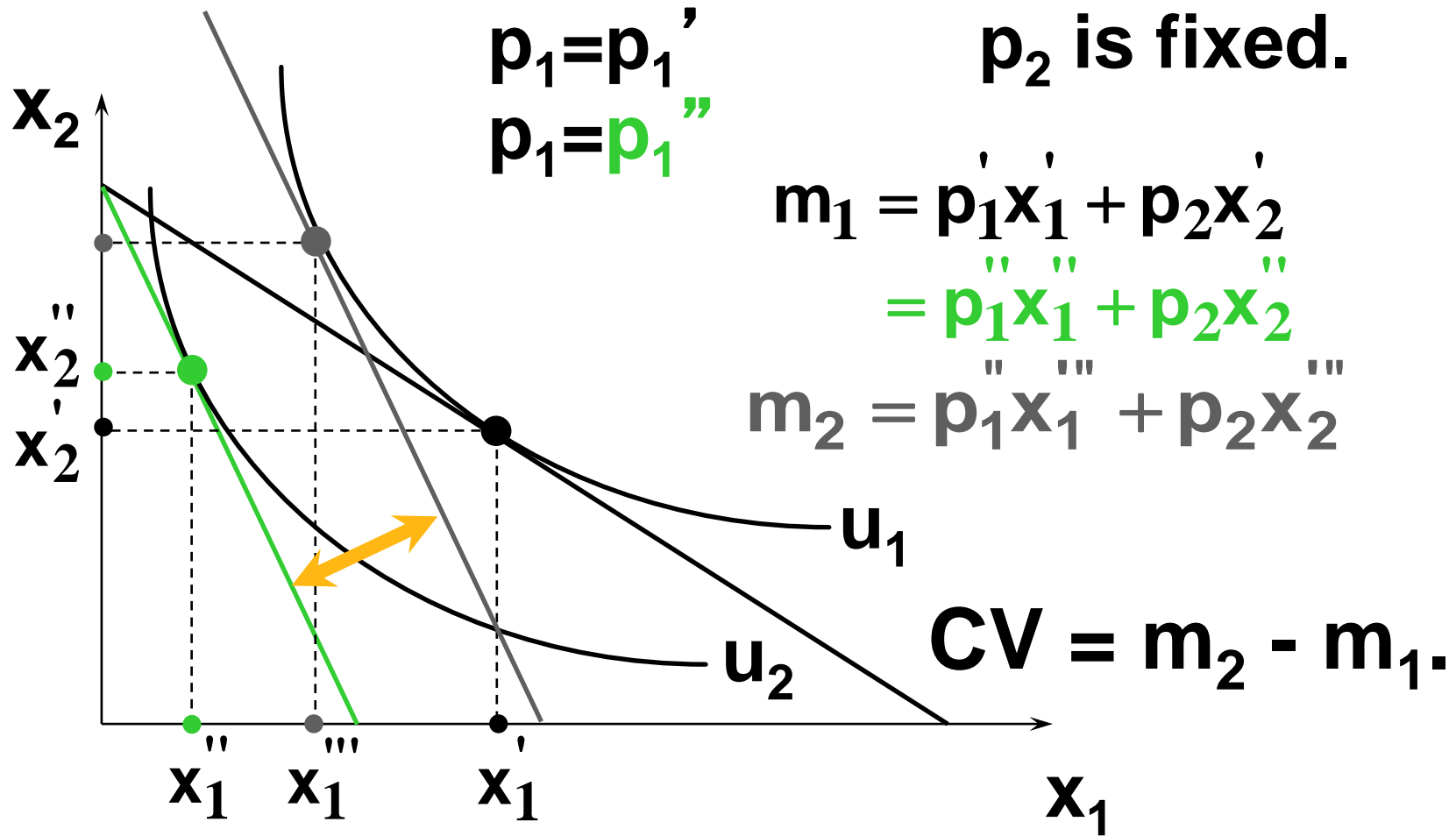

Equivalent Variation

- **p_1 rises.**
- **Q: What is the least extra income that, at the original prices, just restores the consumer's original utility level?**
- **A: The Equivalent Variation.**

Equivalent Variation

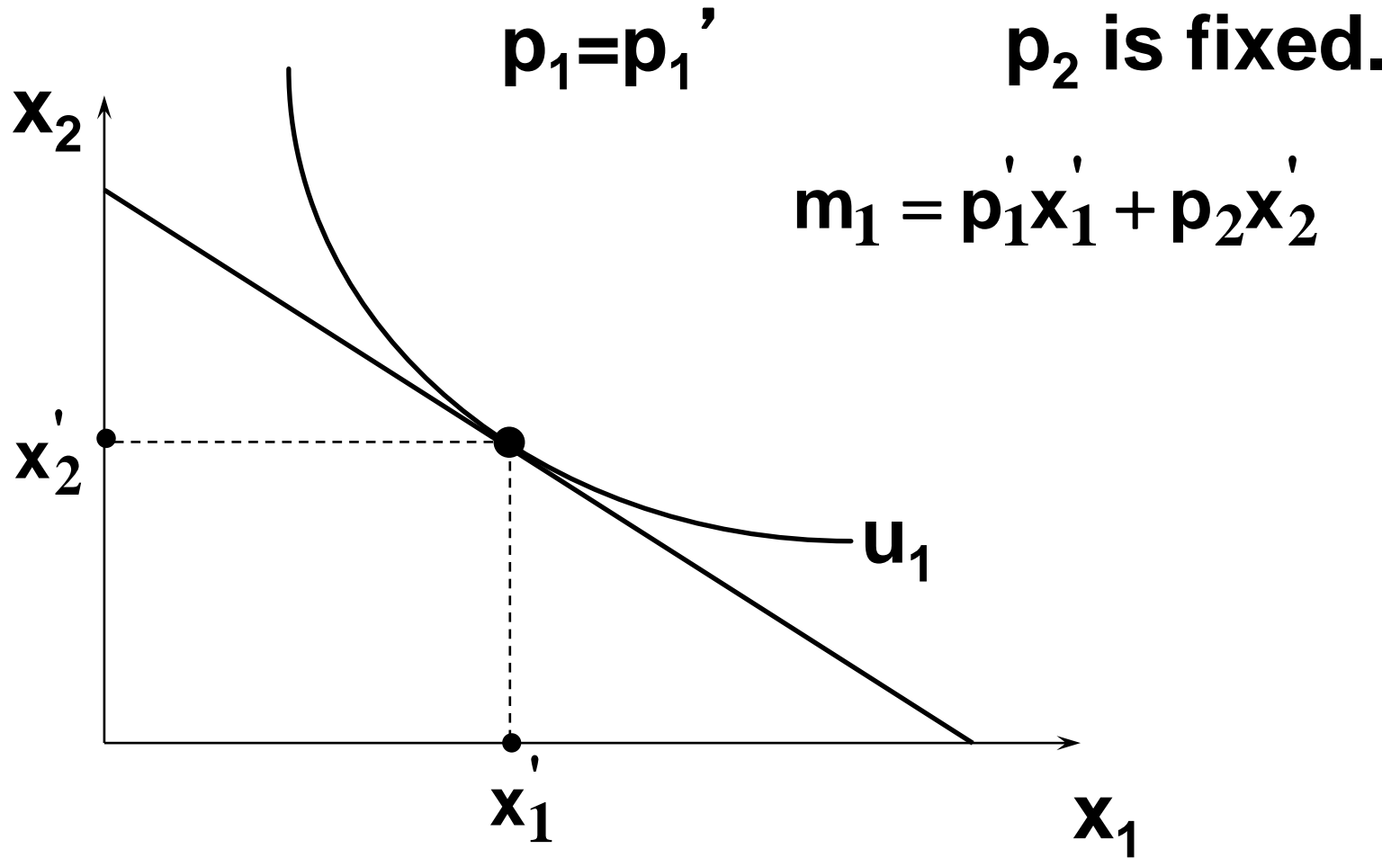

Equivalent Variation

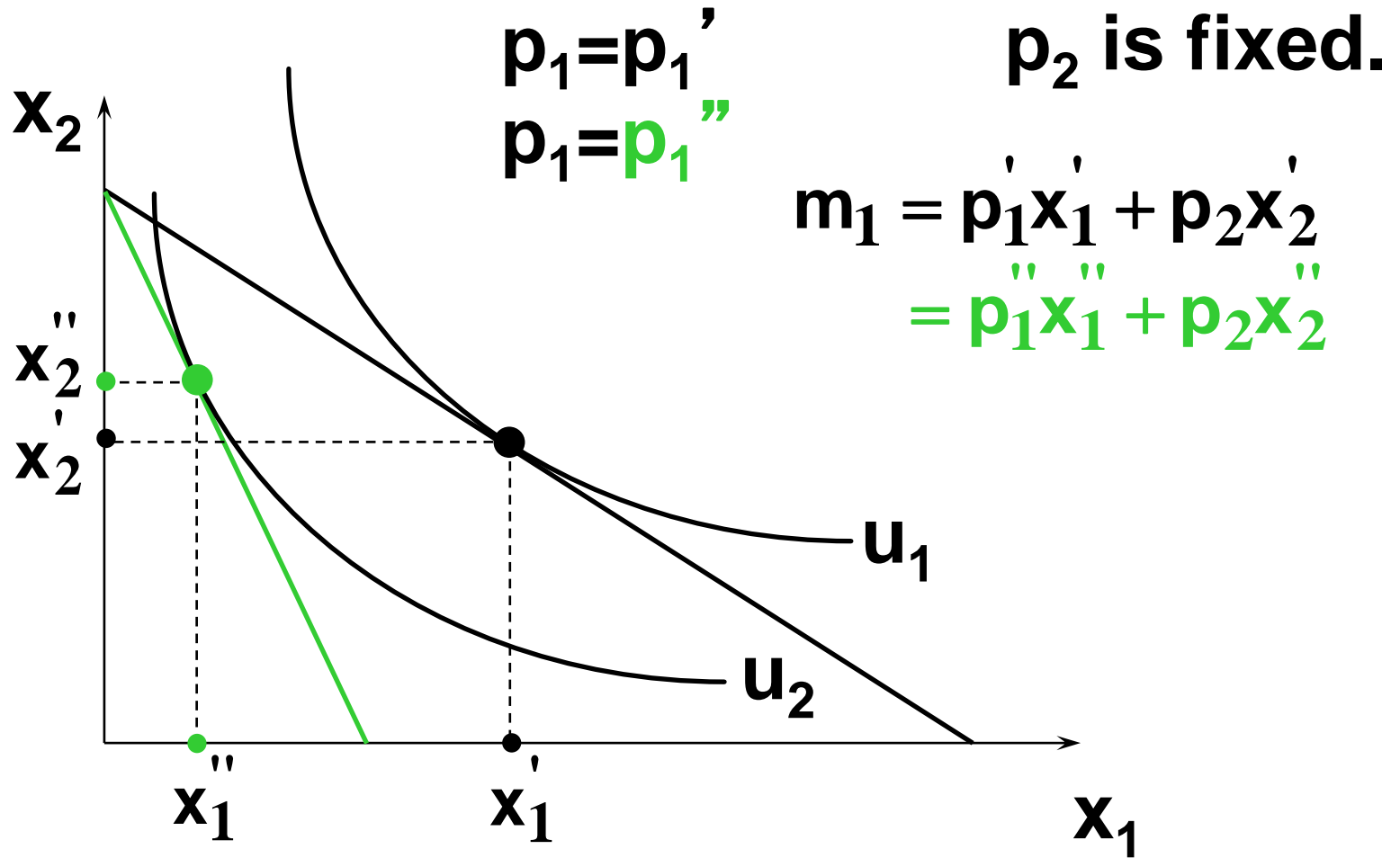

Equivalent Variation

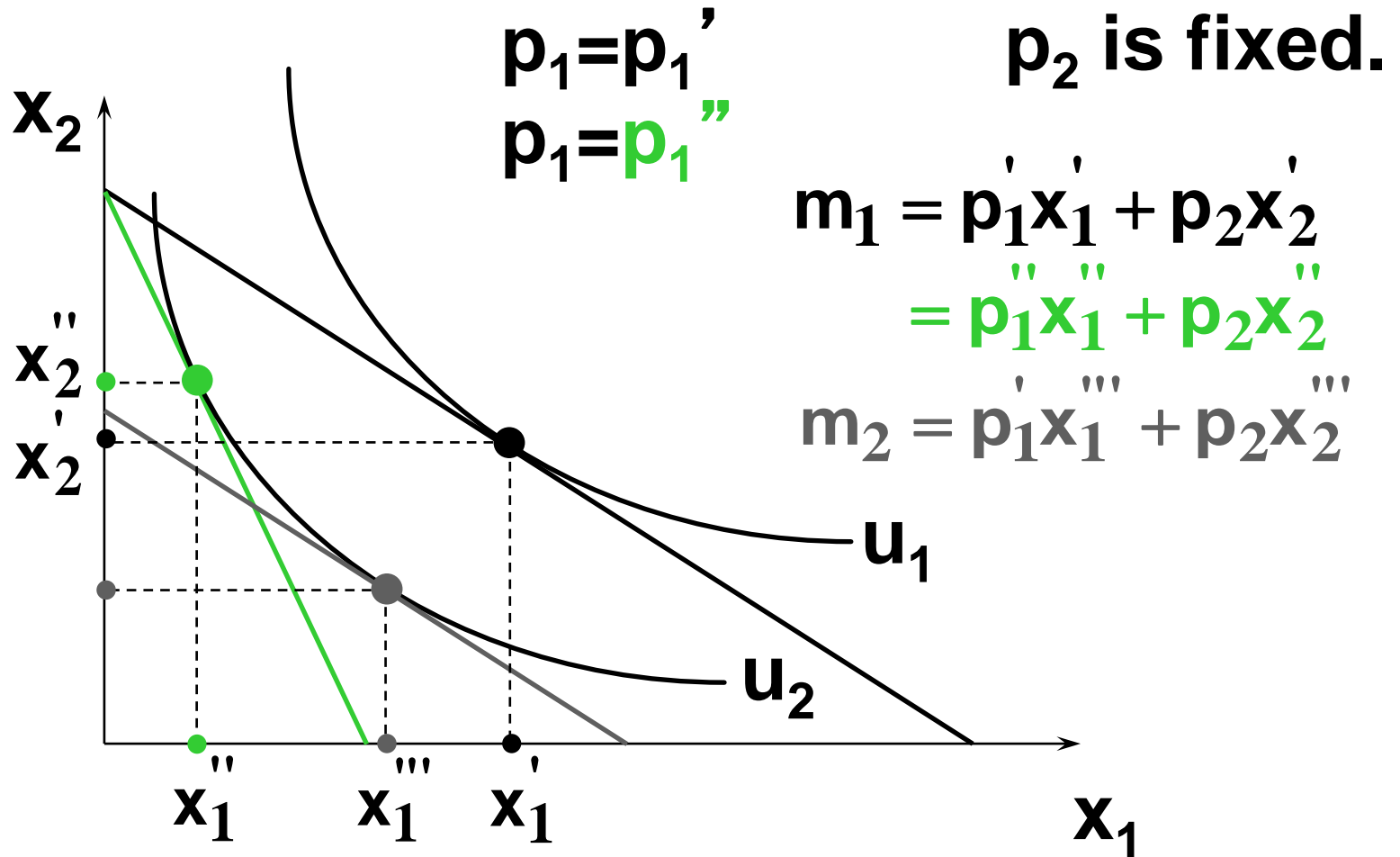

Equivalent Variation

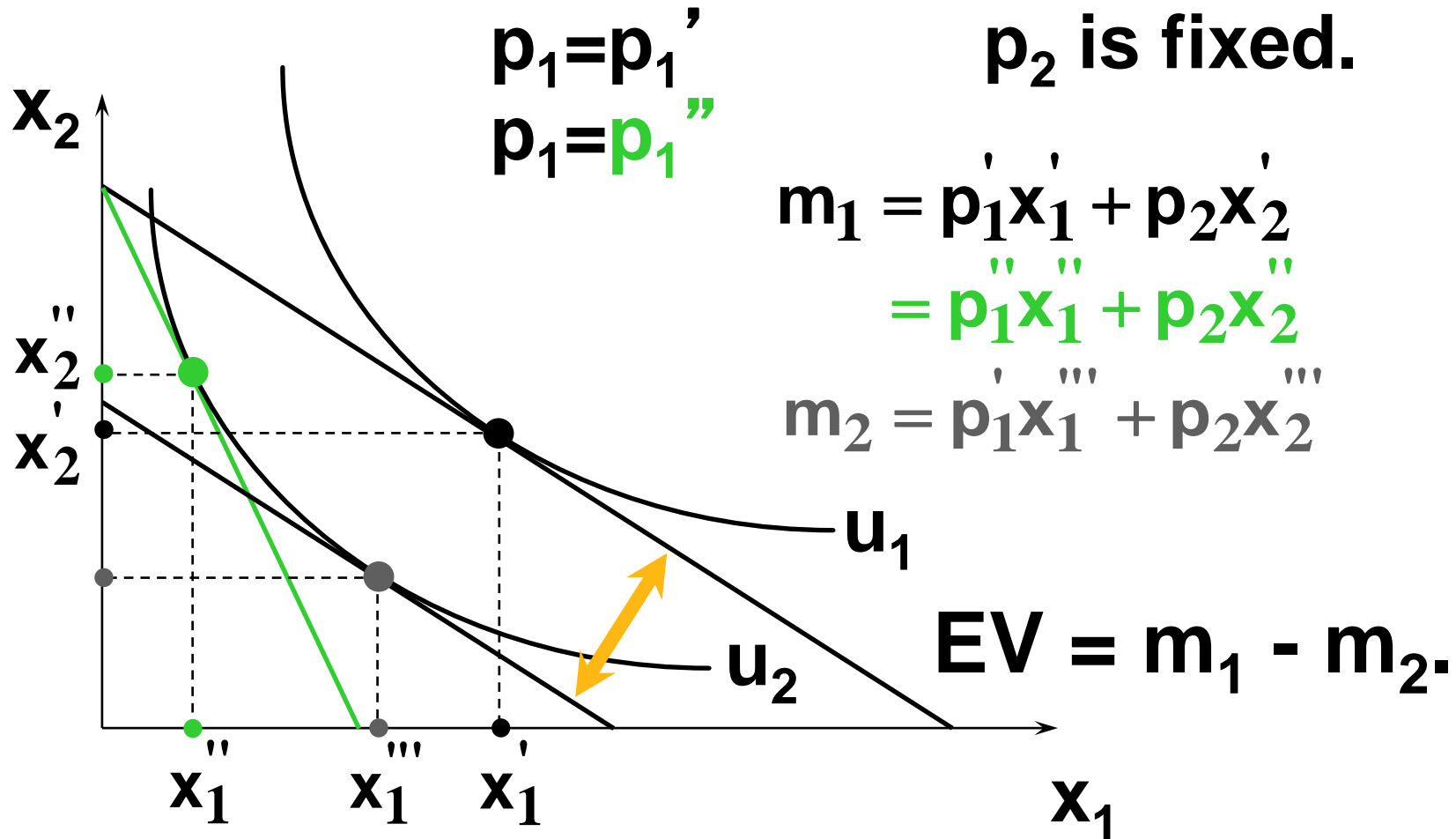

Consumer's Surplus, Compensating Variation and Equivalent Variation

- **Relationship 1: When the consumer's preferences are quasilinear, all three measures are the same.**

Consumer's Surplus, Compensating Variation and Equivalent Variation

- **Consider first the change in Consumer's Surplus when p_1 rises from p_1' to p_1'' .**

Consumer's Surplus, Compensating Variation and Equivalent Variation

If $\mathbf{U}(\mathbf{x}_1, \mathbf{x}_2) = \mathbf{v}(\mathbf{x}_1) + \mathbf{x}_2$ then

$$\mathbf{CS}(\mathbf{p}'_1) = \mathbf{v}(\mathbf{x}'_1) - \mathbf{v}(\mathbf{0}) - \mathbf{p}'_1 \mathbf{x}'_1$$

Consumer's Surplus, Compensating Variation and Equivalent Variation

If $\mathbf{U}(\mathbf{x}_1, \mathbf{x}_2) = v(\mathbf{x}_1) + \mathbf{x}_2$ then

$$\mathbf{CS}(p_1') = v(\mathbf{x}_1') - v(\mathbf{0}) - p_1' \mathbf{x}_1'$$

and so the change in CS when p_1 rises from p_1' to p_1'' is

$$\Delta \mathbf{CS} = \mathbf{CS}(p_1') - \mathbf{CS}(p_1'')$$

Consumer's Surplus, Compensating Variation and Equivalent Variation

If $\mathbf{U}(\mathbf{x}_1, \mathbf{x}_2) = v(\mathbf{x}_1) + \mathbf{x}_2$ then

$$\mathbf{CS}(p_1') = v(\mathbf{x}_1') - v(\mathbf{0}) - p_1' \mathbf{x}_1'$$

and so the change in CS when p_1 rises from p_1' to p_1'' is

$$\begin{aligned} \Delta \mathbf{CS} &= \mathbf{CS}(p_1') - \mathbf{CS}(p_1'') \\ &= v(\mathbf{x}_1') - v(\mathbf{0}) - p_1' \mathbf{x}_1' - \left[v(\mathbf{x}_1'') - v(\mathbf{0}) - p_1'' \mathbf{x}_1'' \right] \end{aligned}$$

Consumer's Surplus, Compensating Variation and Equivalent Variation

If $\mathbf{U}(\mathbf{x}_1, \mathbf{x}_2) = v(\mathbf{x}_1) + \mathbf{x}_2$ then

$$\mathbf{CS}(p_1') = v(\mathbf{x}_1') - v(\mathbf{0}) - p_1' \mathbf{x}_1'$$

and so the change in CS when p_1 rises from p_1' to p_1'' is

$$\begin{aligned} \Delta \mathbf{CS} &= \mathbf{CS}(p_1') - \mathbf{CS}(p_1'') \\ &= v(\mathbf{x}_1') - v(\mathbf{0}) - p_1' \mathbf{x}_1' - \left[v(\mathbf{x}_1'') - v(\mathbf{0}) - p_1'' \mathbf{x}_1'' \right] \\ &= v(\mathbf{x}_1') - v(\mathbf{x}_1'') - (p_1' \mathbf{x}_1' - p_1'' \mathbf{x}_1''). \end{aligned}$$

Consumer's Surplus, Compensating Variation and Equivalent Variation

□ **Now consider the change in CV when p_1 rises from p_1' to p_1'' .**

□ **The consumer's utility for given p_1 is**

$$v(x_1^*(p_1)) + m - p_1 x_1^*(p_1)$$

and CV is the extra income which, at the new prices, makes the consumer's utility the same as at the old prices. That is, ...

Consumer's Surplus, Compensating Variation and Equivalent Variation

$$\begin{aligned} & \mathbf{v}(\mathbf{x}'_1) + \mathbf{m} - \mathbf{p}'_1 \mathbf{x}'_1 \\ = & \mathbf{v}(\mathbf{x}''_1) + \mathbf{m} + \mathbf{CV} - \mathbf{p}''_1 \mathbf{x}''_1. \end{aligned}$$

Consumer's Surplus, Compensating Variation and Equivalent Variation

$$\begin{aligned} & v(\mathbf{x}'_1) + m - \mathbf{p}'_1 \mathbf{x}'_1 \\ &= v(\mathbf{x}''_1) + m + \mathbf{CV} - \mathbf{p}''_1 \mathbf{x}''_1. \end{aligned}$$

So

$$\begin{aligned} \mathbf{CV} &= v(\mathbf{x}'_1) - v(\mathbf{x}''_1) - (\mathbf{p}'_1 \mathbf{x}'_1 - \mathbf{p}''_1 \mathbf{x}''_1) \\ &= \Delta \mathbf{CS}. \end{aligned}$$

Consumer's Surplus, Compensating Variation and Equivalent Variation

□ **Now consider the change in EV when p_1 rises from p_1' to p_1'' .**

□ **The consumer's utility for given p_1 is**

$$v(x_1^*(p_1)) + m - p_1 x_1^*(p_1)$$

and EV is the extra income which, at the old prices, makes the consumer's utility the same as at the new prices. That is, ...

Consumer's Surplus, Compensating Variation and Equivalent Variation

$$\begin{aligned} & \mathbf{v}(\mathbf{x}'_1) + \mathbf{m} - \mathbf{p}'_1 \mathbf{x}'_1 \\ = & \mathbf{v}(\mathbf{x}''_1) + \mathbf{m} + \mathbf{EV} - \mathbf{p}''_1 \mathbf{x}''_1. \end{aligned}$$

Consumer's Surplus, Compensating Variation and Equivalent Variation

$$\begin{aligned} & v(\mathbf{x}'_1) + m - \mathbf{p}'_1 \mathbf{x}'_1 \\ &= v(\mathbf{x}''_1) + m + \mathbf{EV} - \mathbf{p}''_1 \mathbf{x}''_1. \end{aligned}$$

That is,

$$\begin{aligned} \mathbf{EV} &= v(\mathbf{x}'_1) - v(\mathbf{x}''_1) - (\mathbf{p}'_1 \mathbf{x}'_1 - \mathbf{p}''_1 \mathbf{x}''_1) \\ &= \Delta \mathbf{CS}. \end{aligned}$$

Consumer's Surplus, Compensating Variation and Equivalent Variation

So when the consumer has quasilinear utility,

$$\mathbf{CV = EV = \Delta CS.}$$

But, otherwise, we have:

Relationship 2: In size, $EV < \Delta CS < CV$.

Producer's Surplus

- **Changes in a firm's welfare can be measured in dollars much as for a consumer.**

Producer's Surplus

Output price (p)

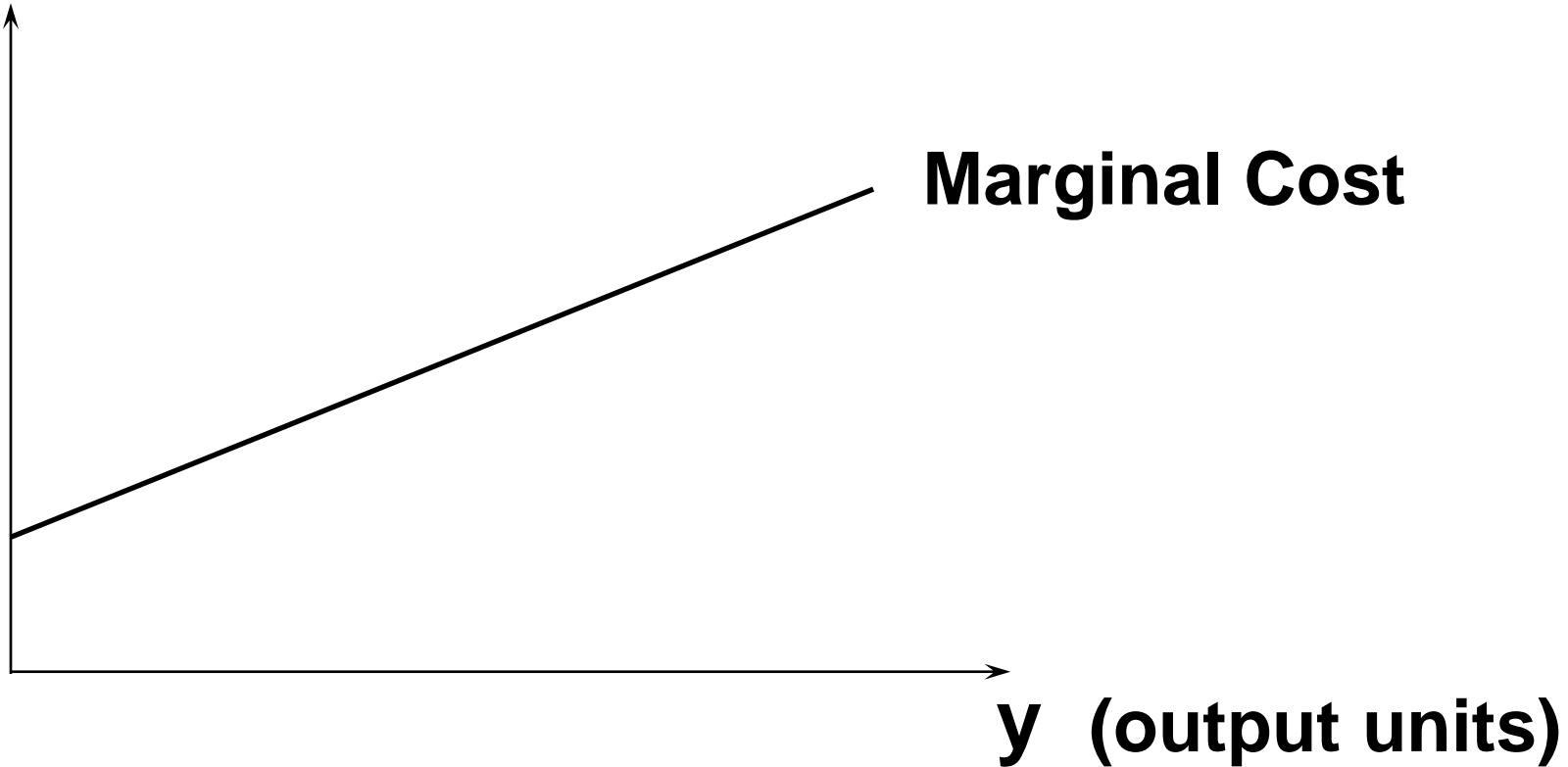

Producer's Surplus

Output price (p)

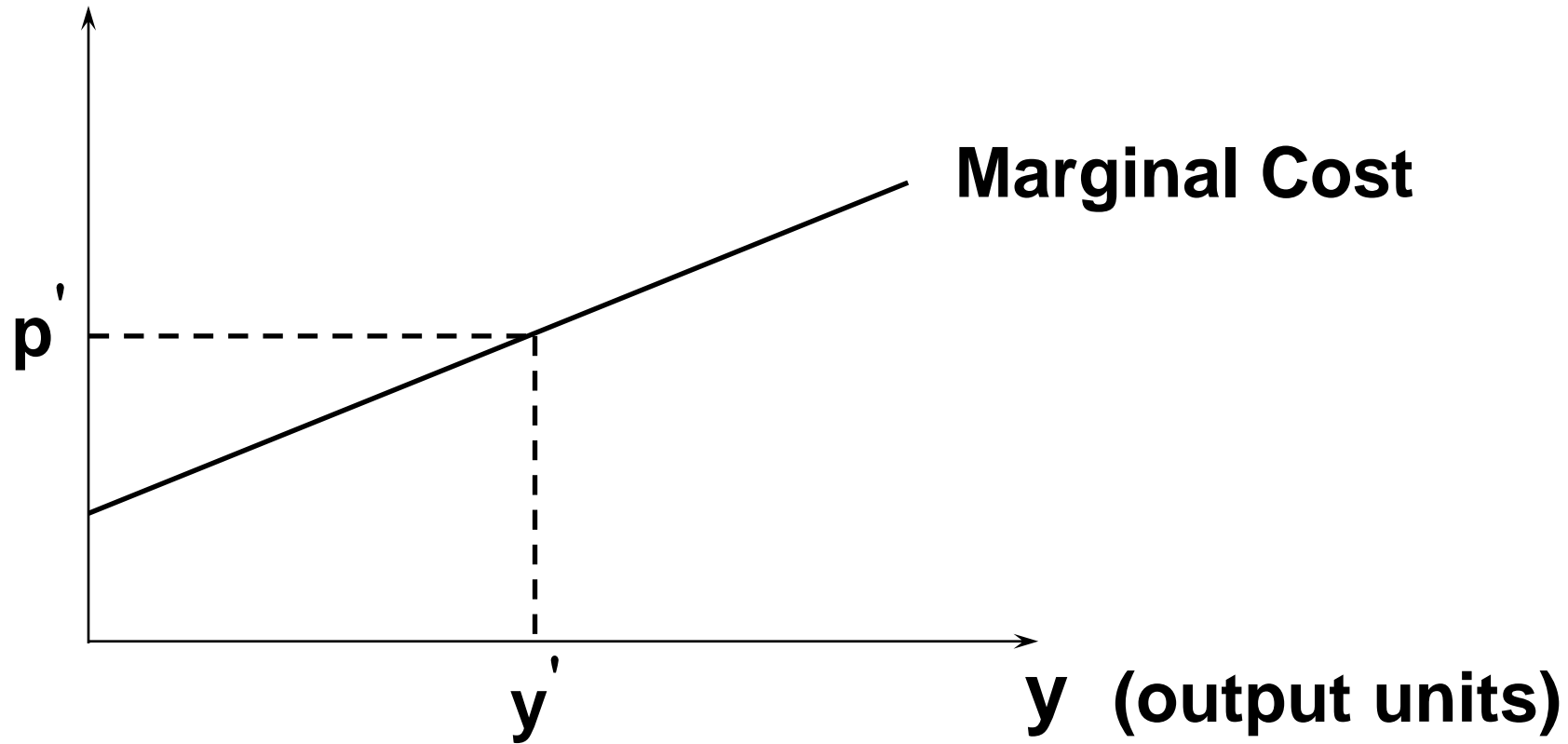

Producer's Surplus

Output price (p)

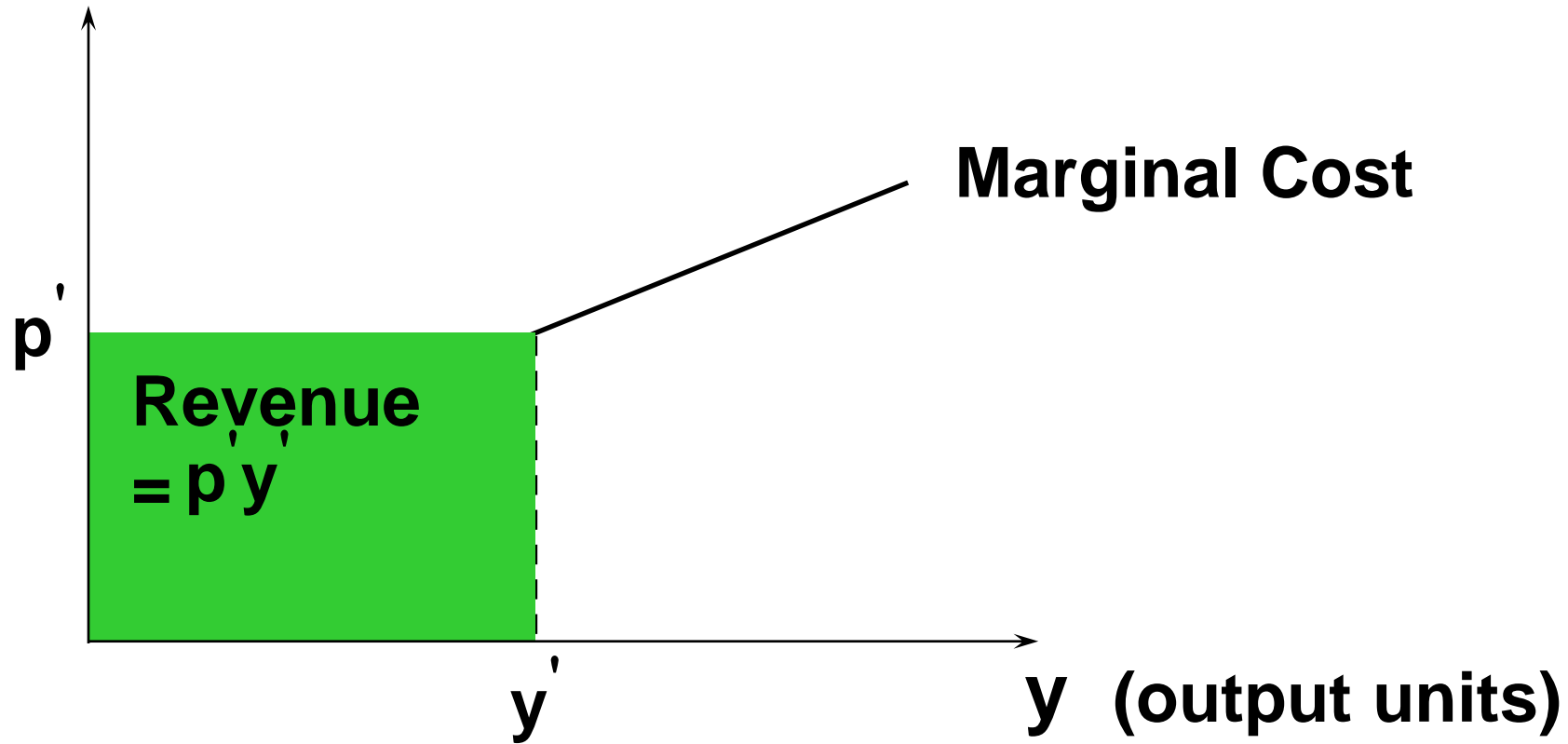

Producer's Surplus

Output price (p)

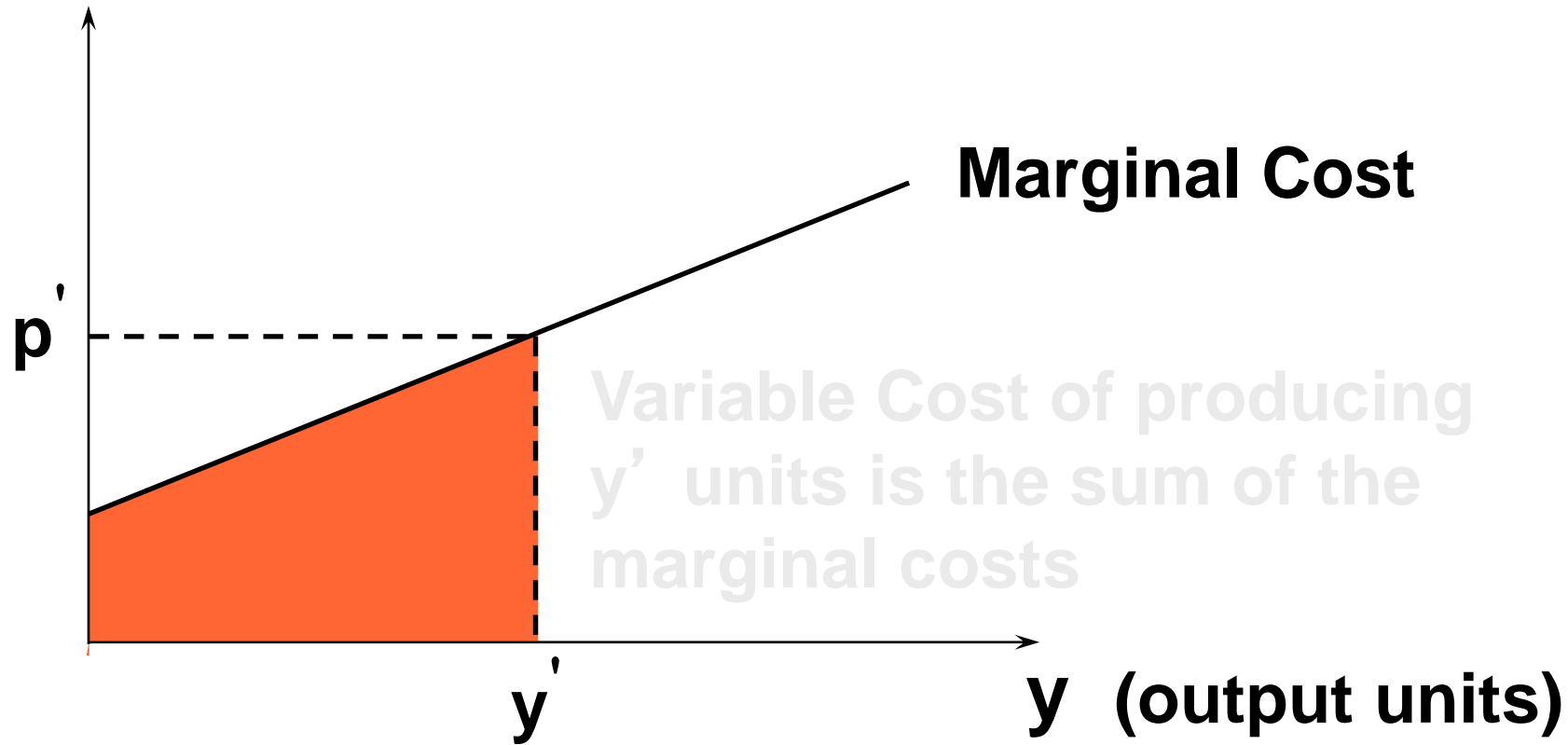

Producer's Surplus

Output price (p)

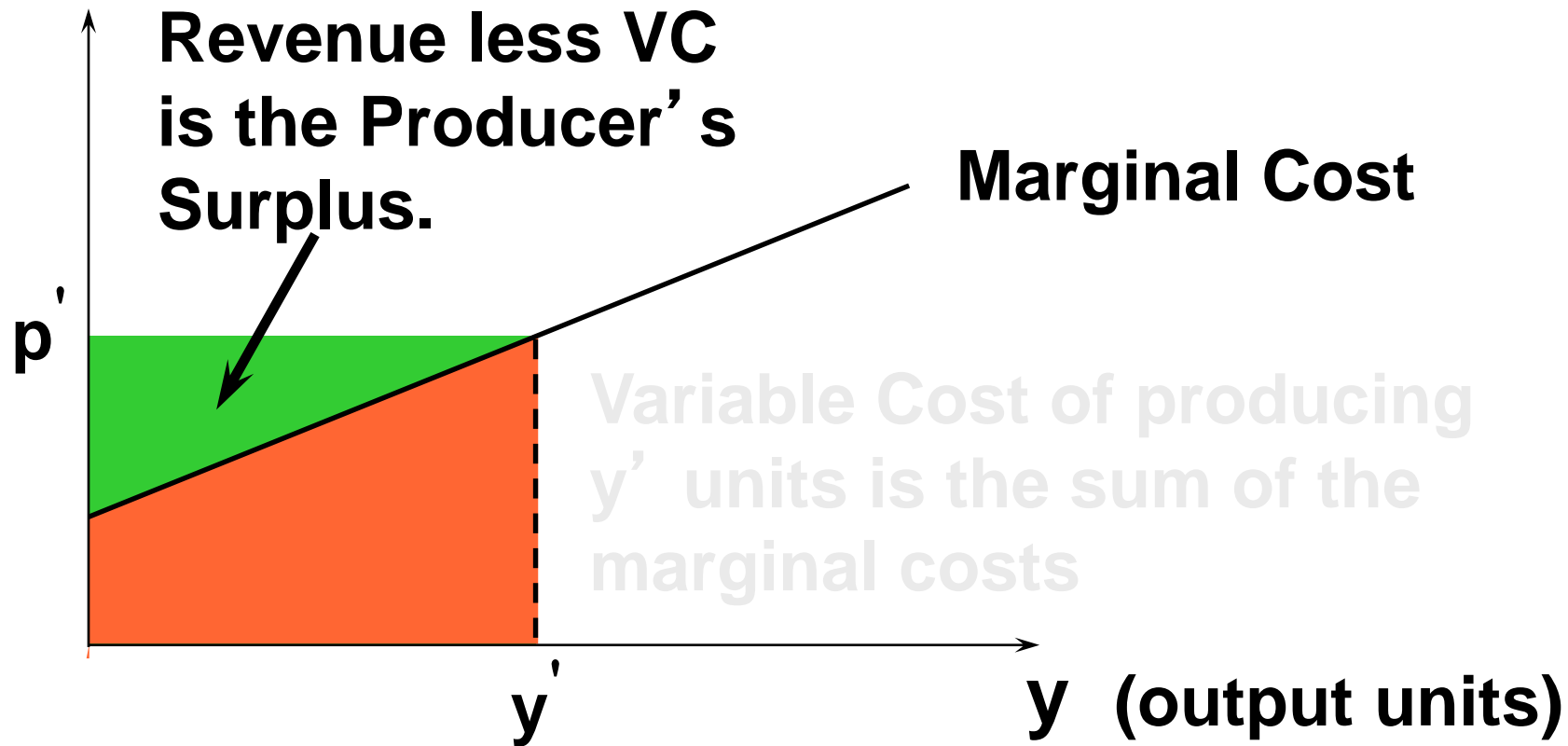

Benefit-Cost Analysis

- **Can we measure in money units the net gain, or loss, caused by a market intervention; e.g., the imposition or the removal of a market regulation?**
- **Yes, by using measures such as the Consumer's Surplus and the Producer's Surplus.**

Benefit-Cost Analysis

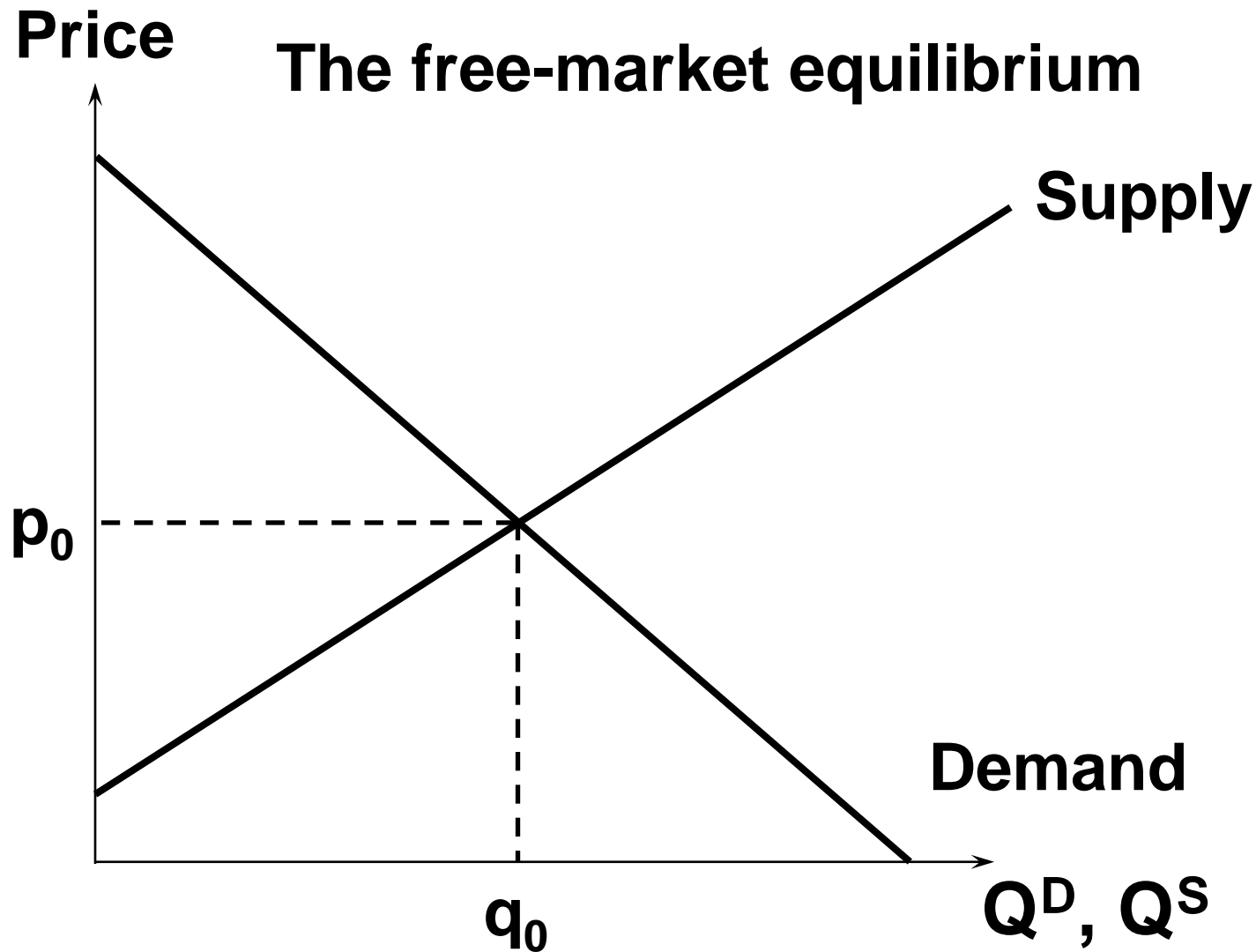

Benefit-Cost Analysis

Price

The free-market equilibrium and the gains from trade generated by it.

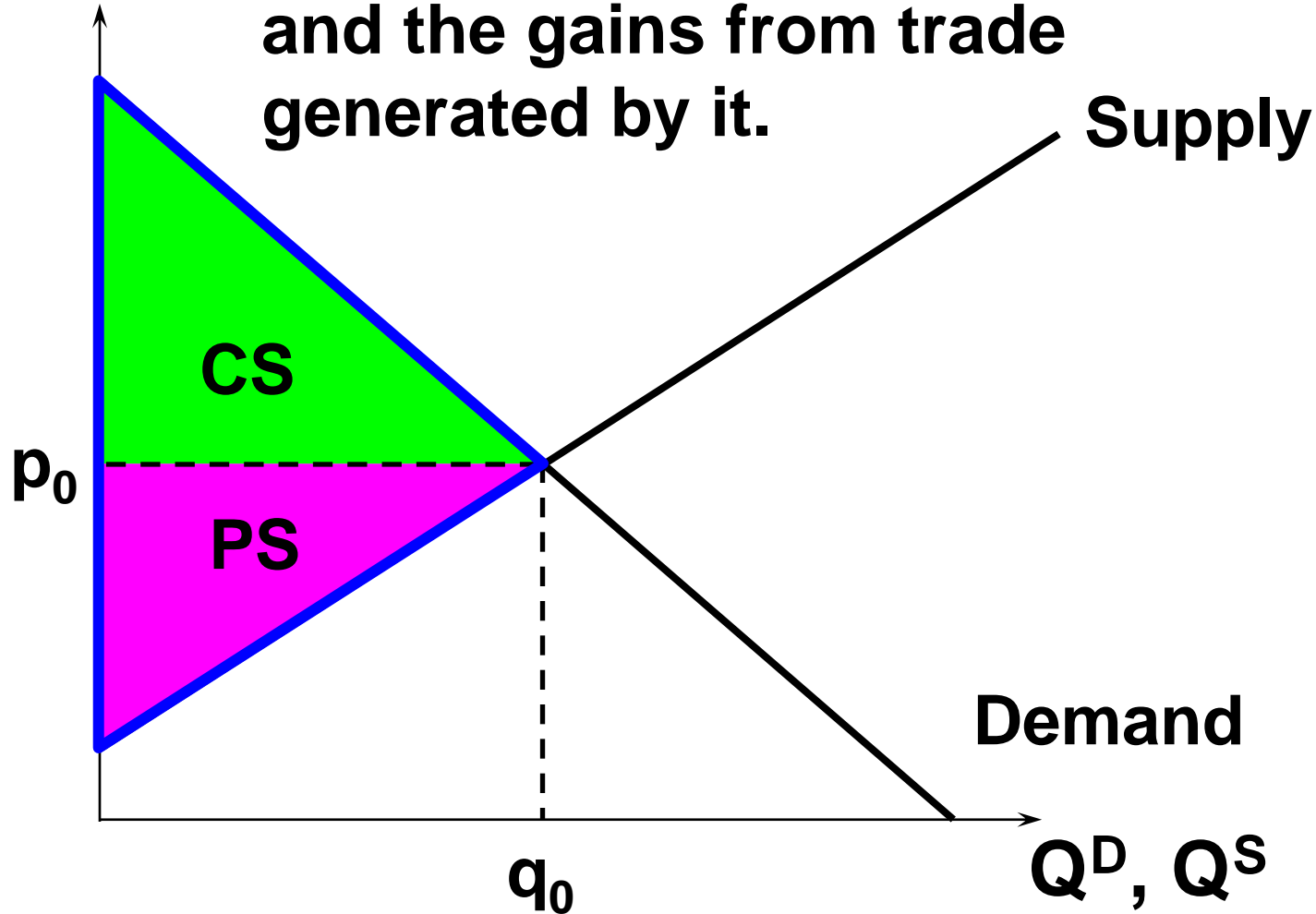

Benefit-Cost Analysis

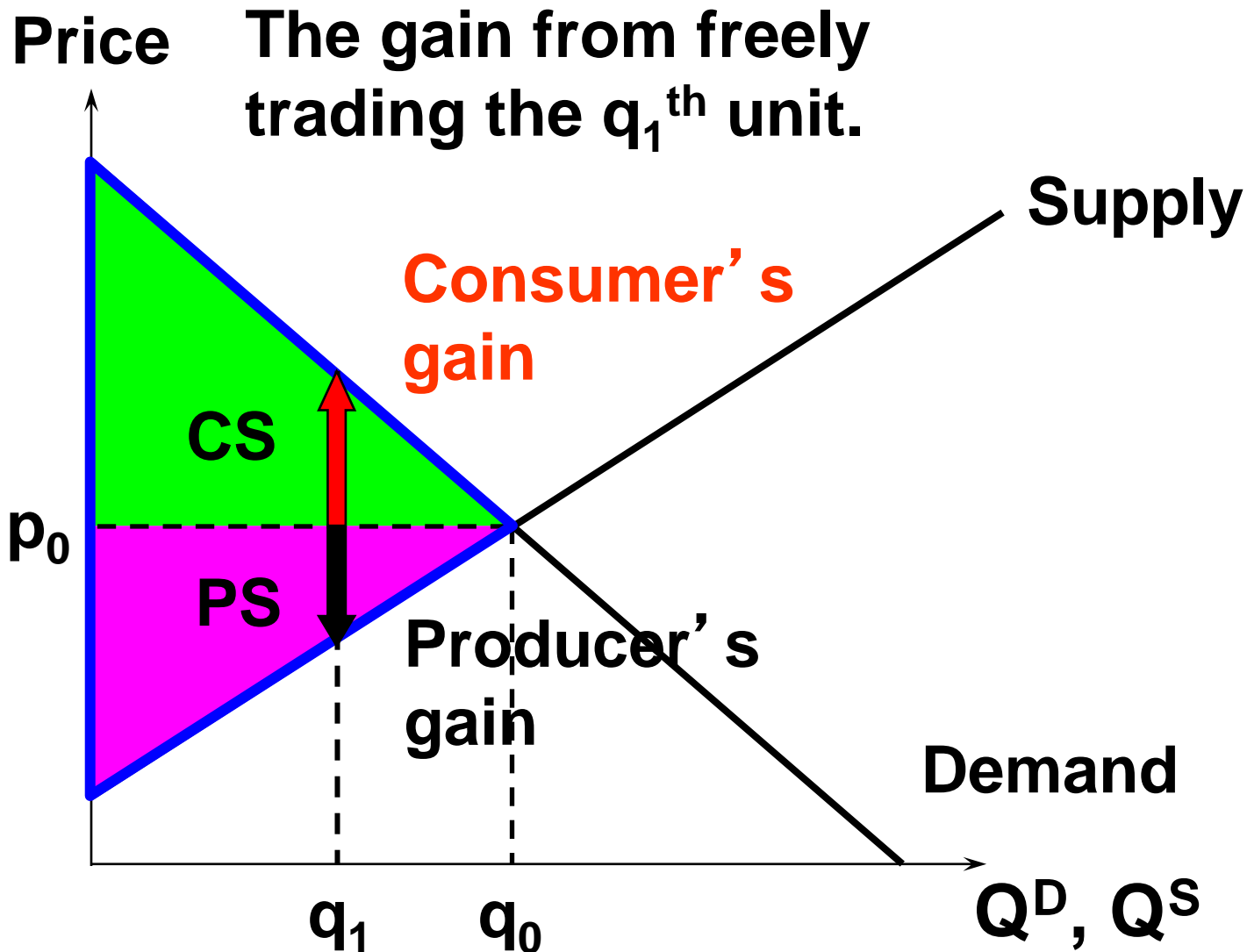

Benefit-Cost Analysis

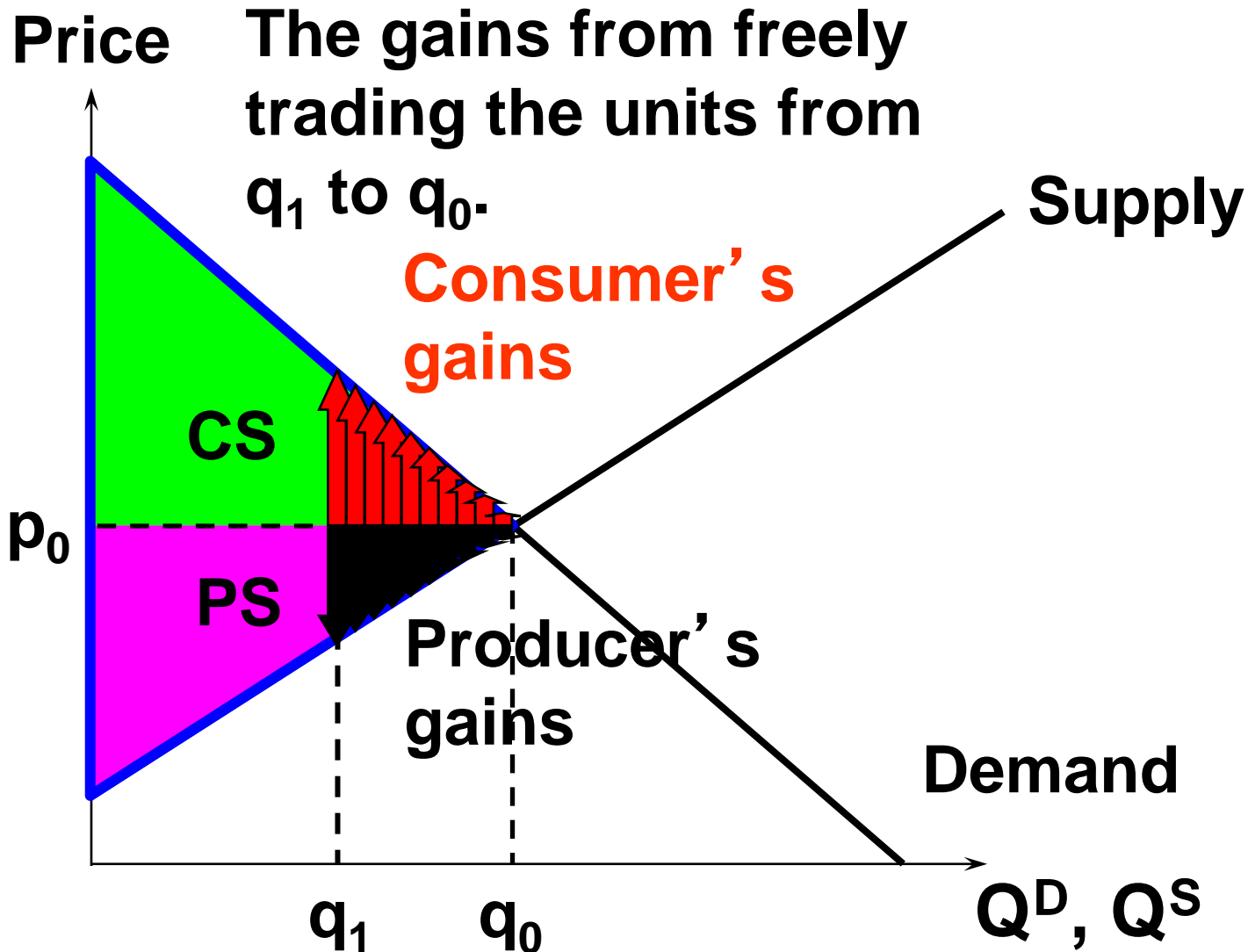

Benefit-Cost Analysis

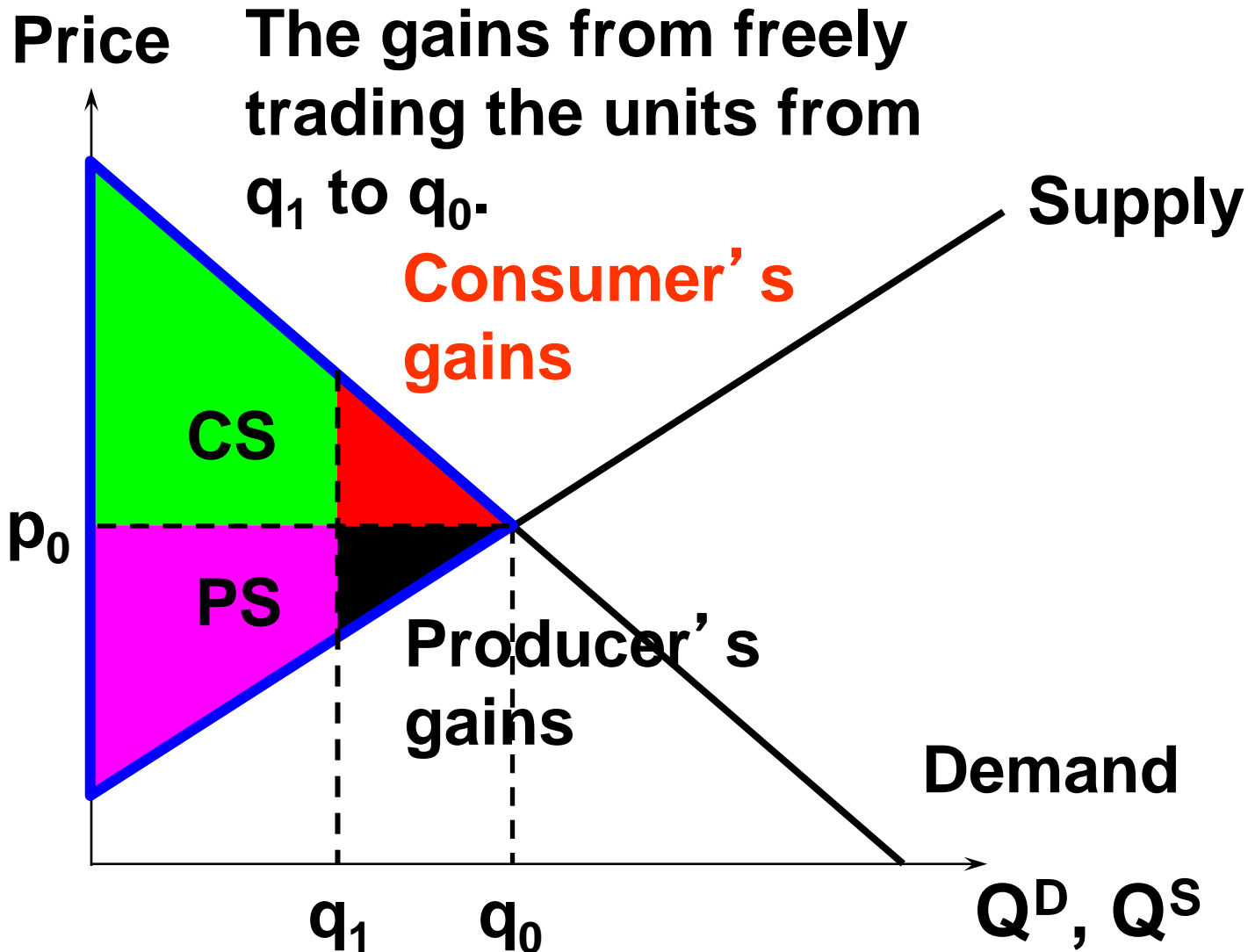

Benefit-Cost Analysis

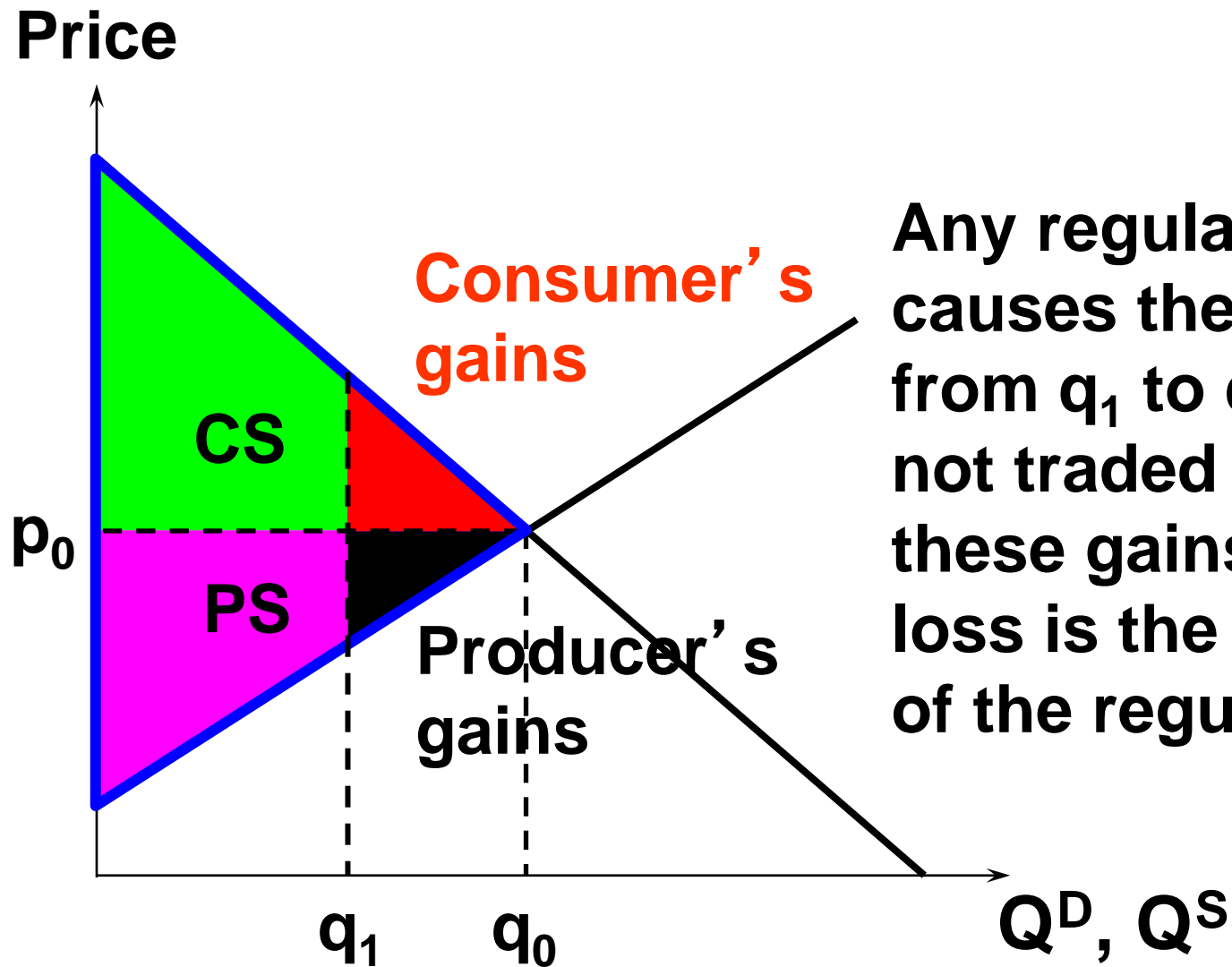

Benefit-Cost Analysis

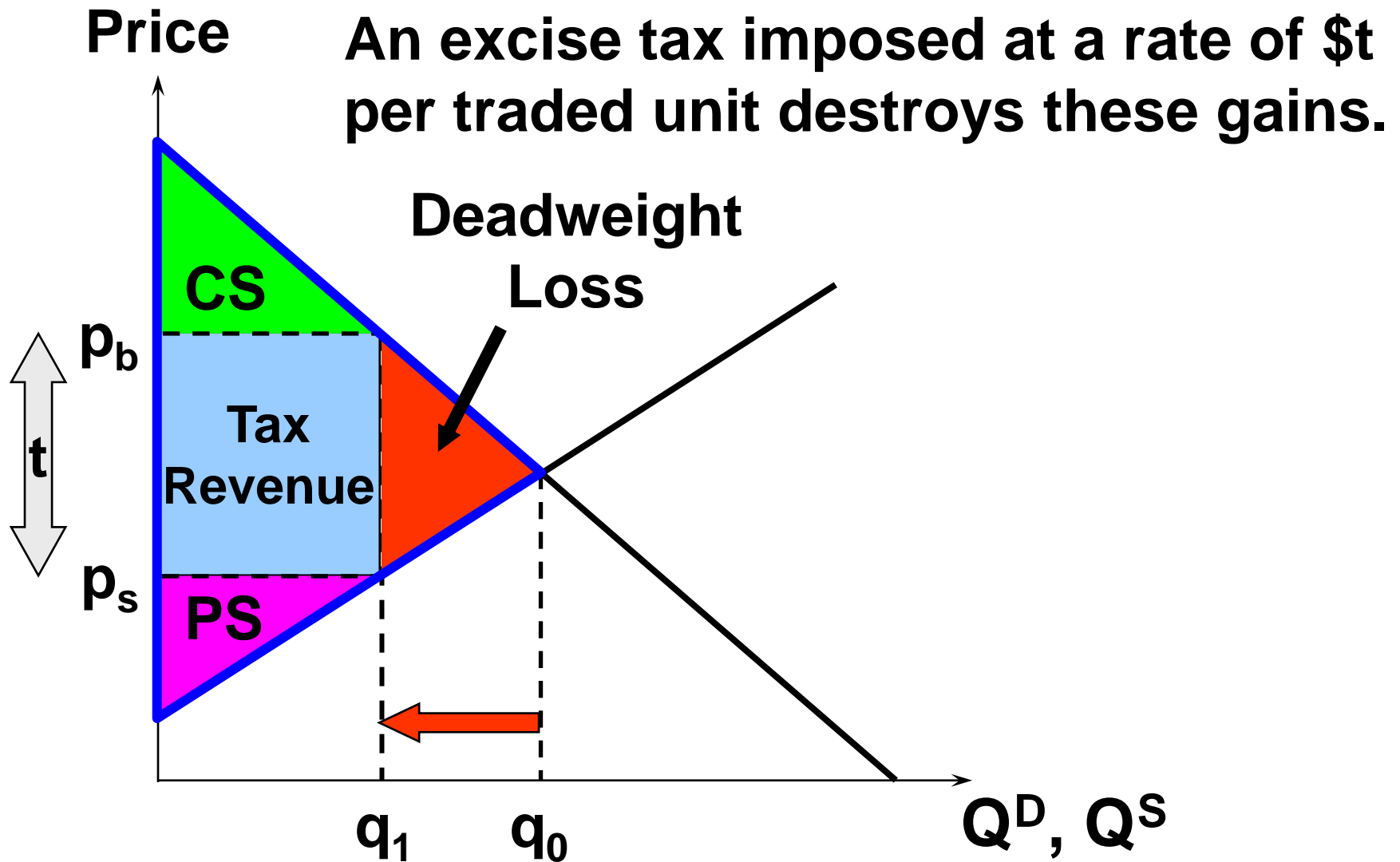

Benefit-Cost Analysis

Price

An excise tax imposed at a rate of \$t per traded unit destroys these gains.

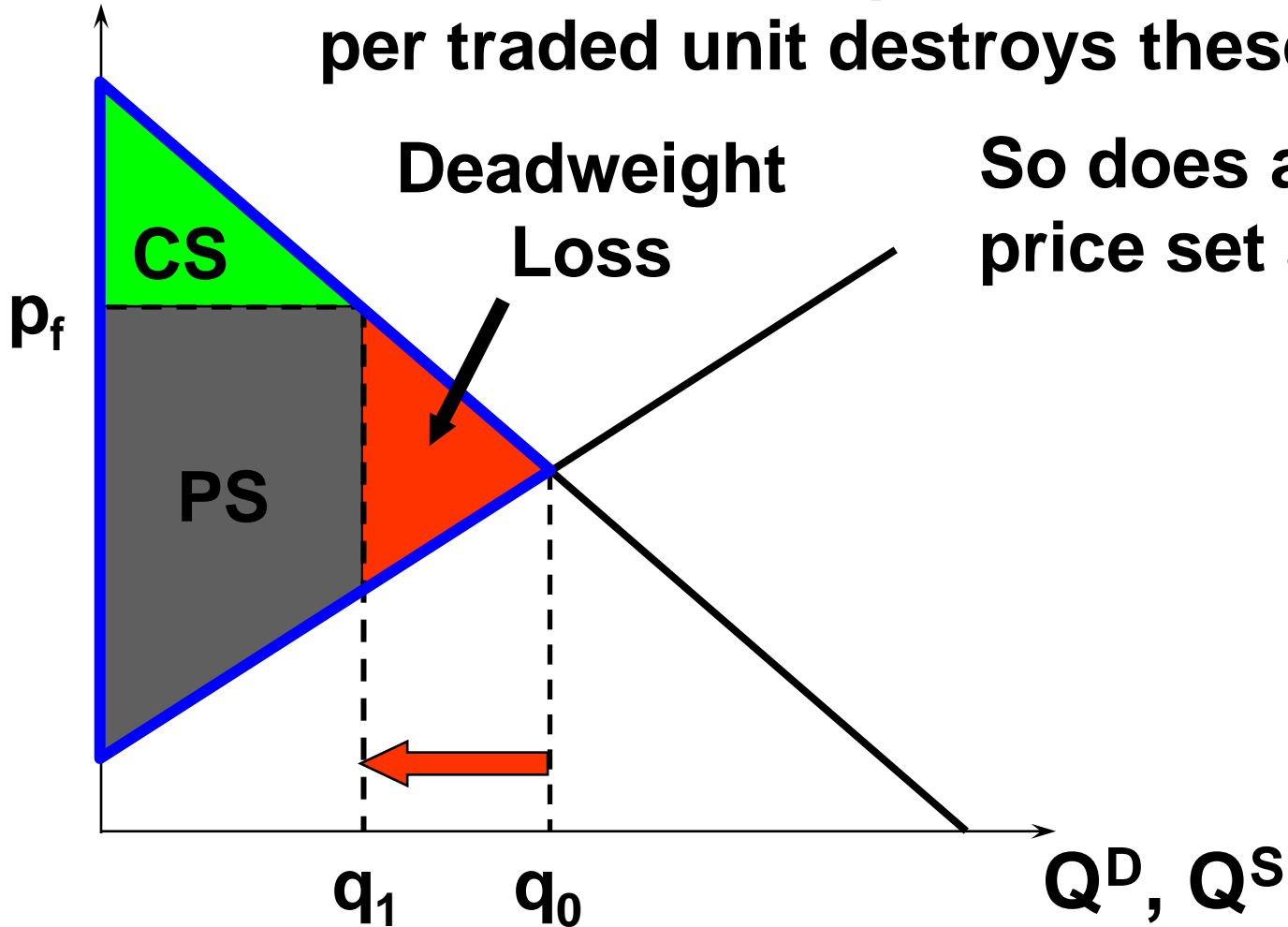

Benefit-Cost Analysis

Price

An excise tax imposed at a rate of \$
per traded unit destroys these gains.

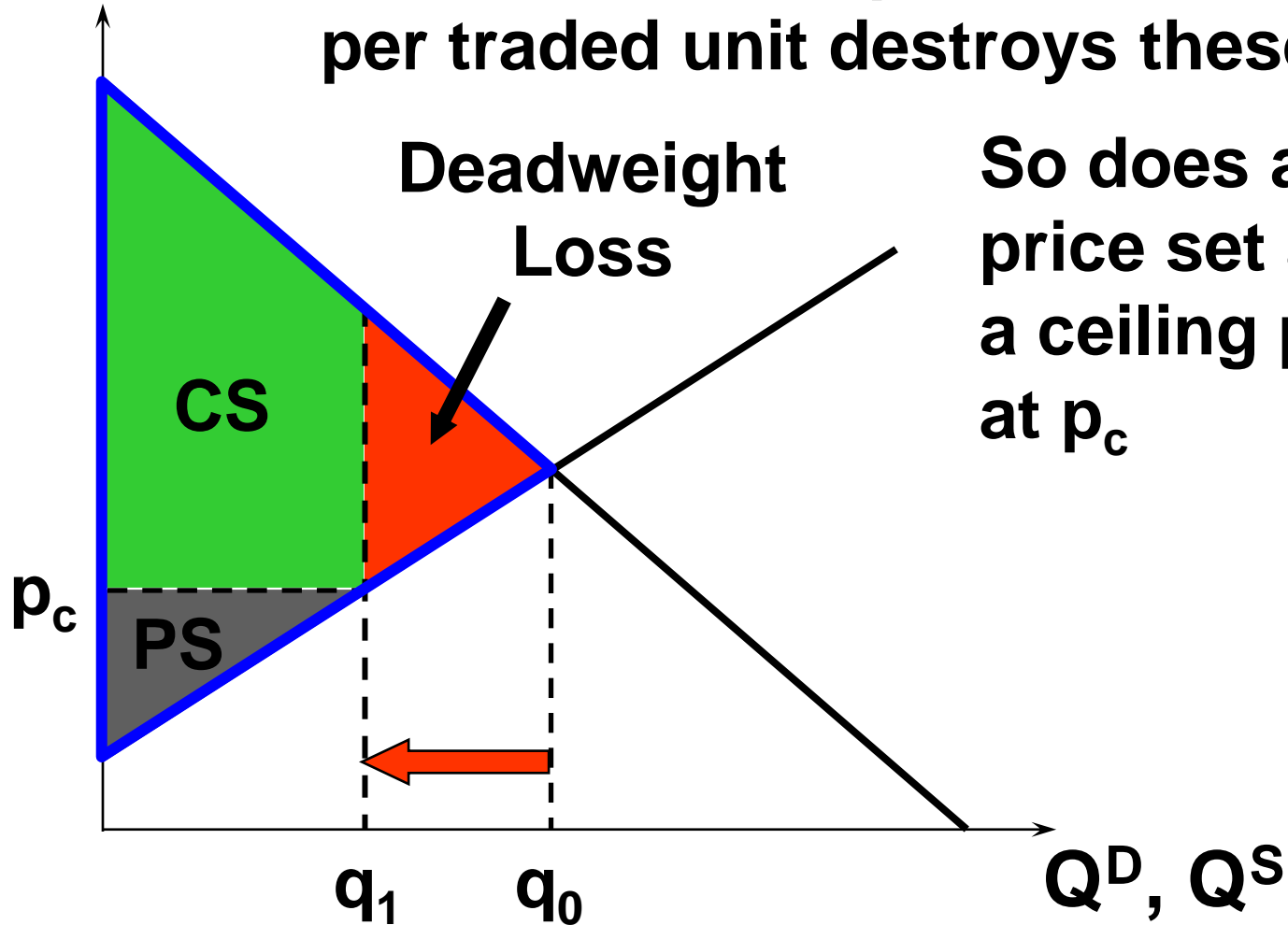

So does a floor
price set at p_f ,
a ceiling price set
at p_c

Benefit-Cost Analysis

Price

An excise tax imposed at a rate of \$
per traded unit destroys these gains.

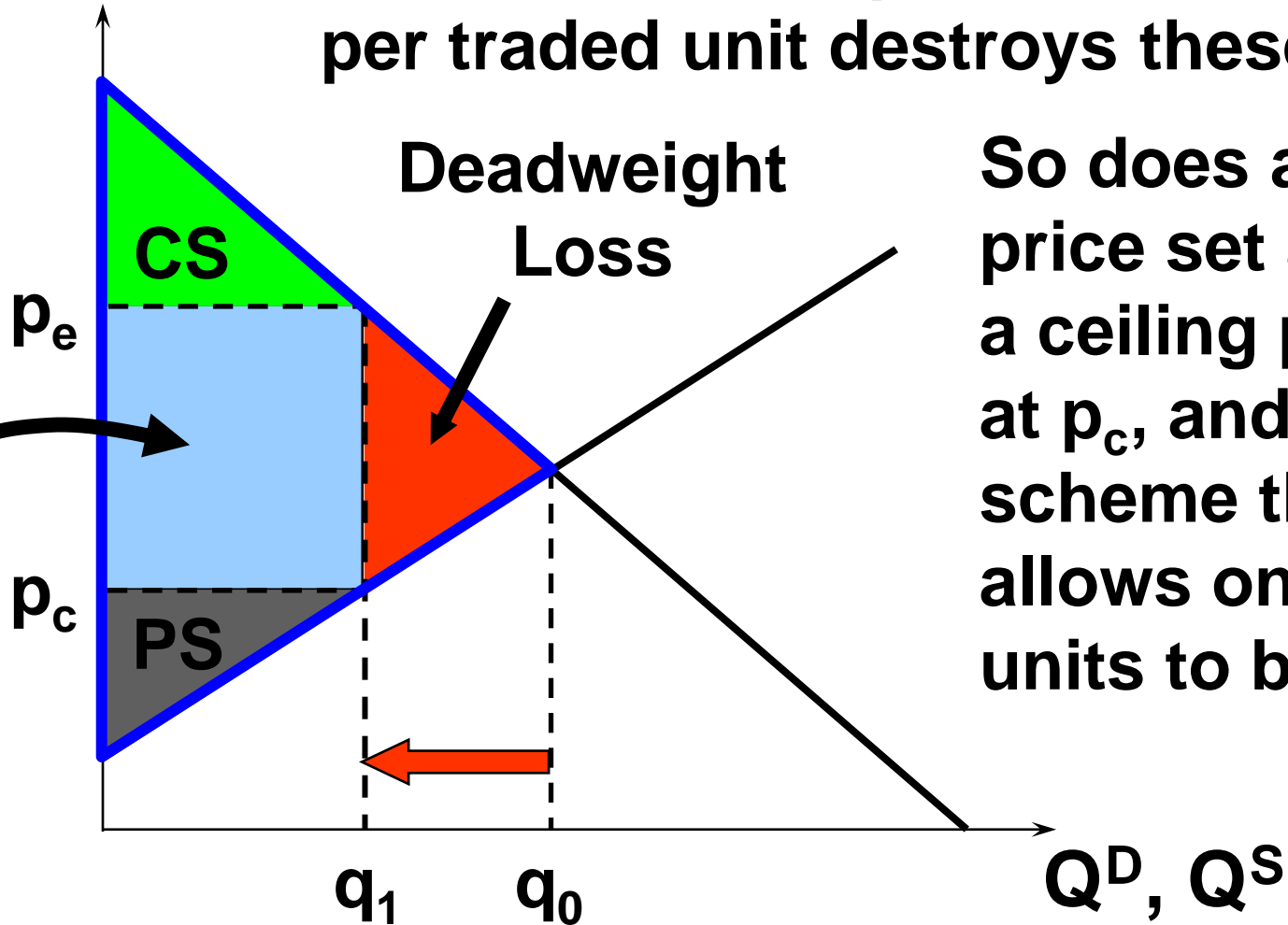

So does a floor
price set at p_f ,
a ceiling price set
at p_c , and a ration
scheme that
allows only q_1
units to be traded.

Revenue received by holders of ration coupons.

From Individual to Market Demand Functions

- **Think of an economy containing n consumers, denoted by $i = 1, \dots, n$.**
- **Consumer i 's ordinary demand function for commodity j is**

$$x_j^{*i}(p_1, p_2, m^i)$$

From Individual to Market

Demand Functions

- **When all consumers are price-takers, the market demand function for commodity j is**

$$X_j(p_1, p_2, m^1, \dots, m^n) = \sum_{i=1}^n x_j^{*i}(p_1, p_2, m^i).$$

- **If all consumers are identical then**

$$X_j(p_1, p_2, M) = n \times x_j^*(p_1, p_2, m)$$

where $M = nm$.

From Individual to Market Demand Functions

- **The market demand curve is the “horizontal sum” of the individual consumers’ demand curves.**
- **E.g. suppose there are only two consumers; $i = A, B$.**

From Individual to Market Demand Functions

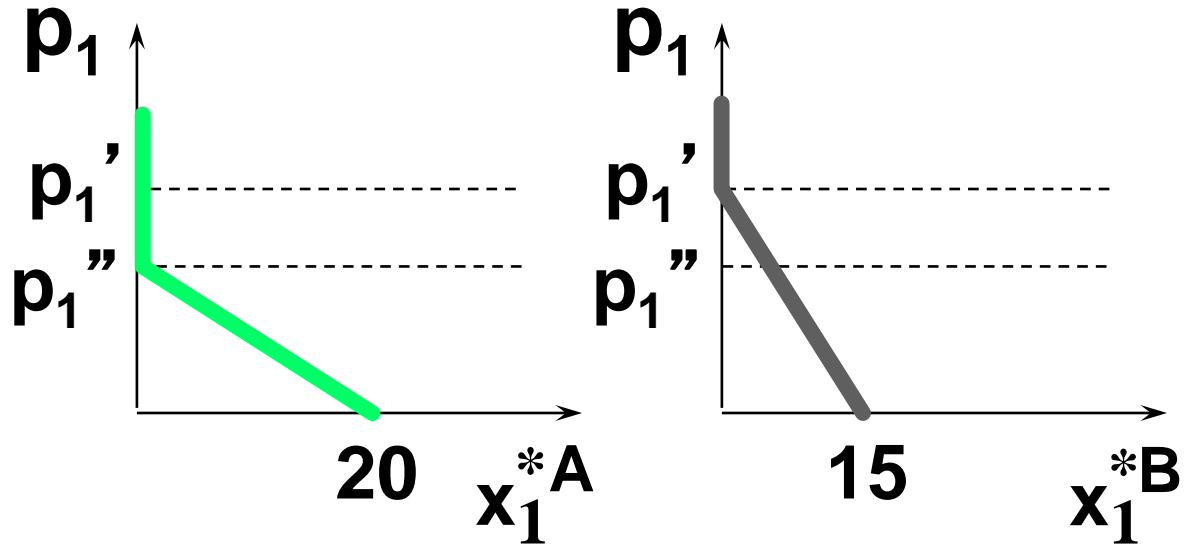

From Individual to Market Demand Functions

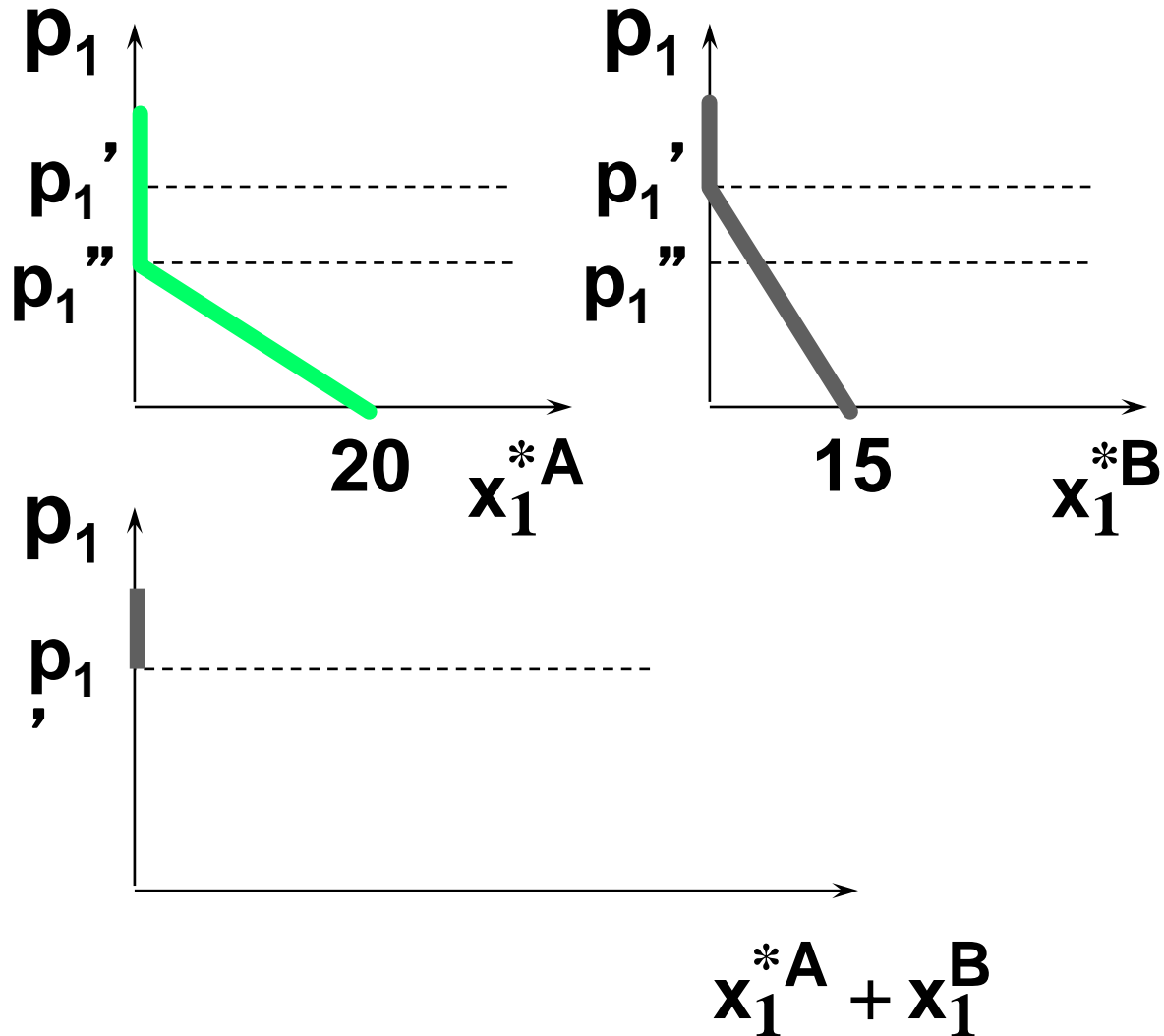

From Individual to Market Demand Functions

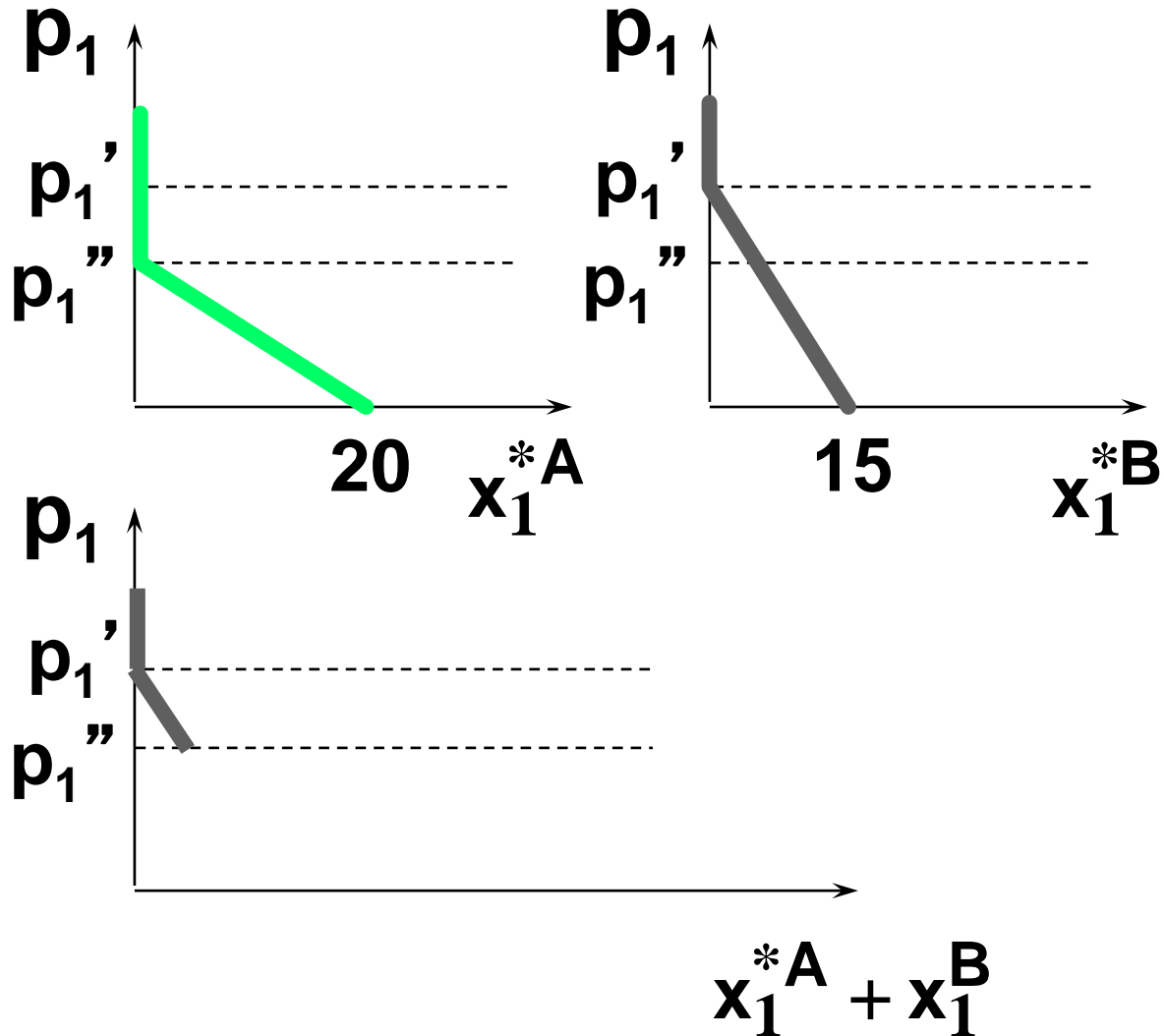

From Individual to Market Demand Functions

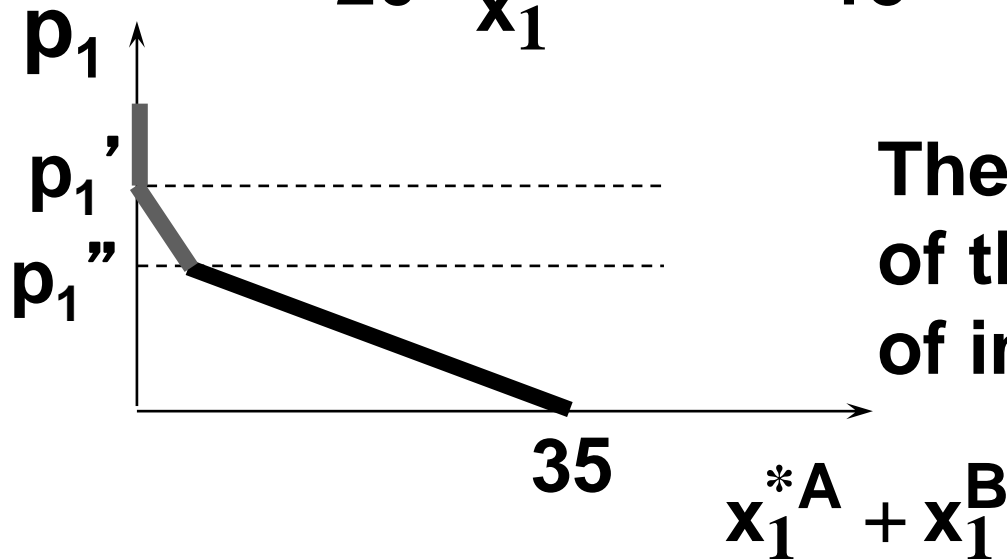
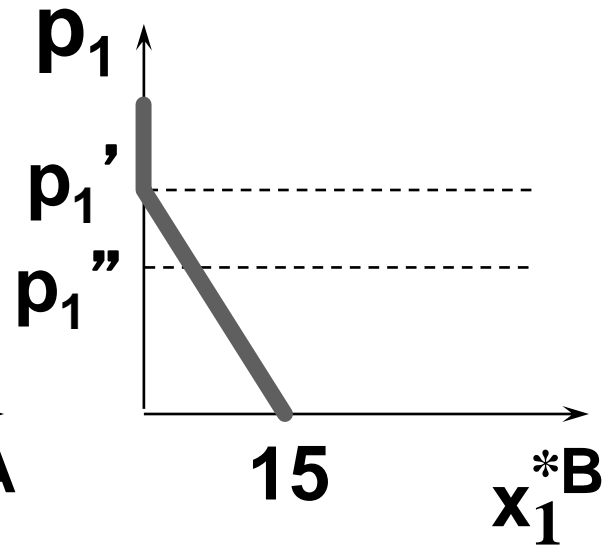
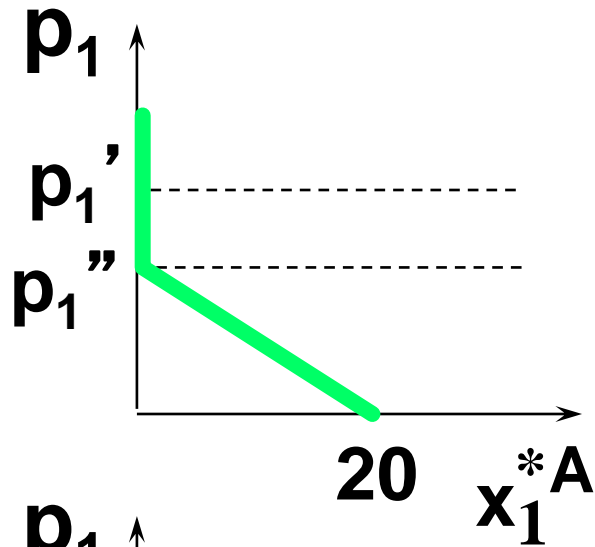

The “horizontal sum”
of the demand curves
of individuals A and B.

Elasticities

- **Elasticity measures the “sensitivity” of one variable with respect to another.**
- **The elasticity of variable X with respect to variable Y is**

$$\varepsilon_{x,y} = \frac{\% \Delta x}{\% \Delta y} \cdot$$

Economic Applications of Elasticity

- **Economists use elasticities to measure the sensitivity of**
 - **quantity demanded of commodity i with respect to the price of commodity i (own-price elasticity of demand)**
 - **demand for commodity i with respect to the price of commodity j (cross-price elasticity of demand).**

Economic Applications of Elasticity

- **demand for commodity i with respect to income (income elasticity of demand)**
- **quantity supplied of commodity i with respect to the price of commodity i (own-price elasticity of supply)**

Economic Applications of Elasticity

- **quantity supplied of commodity i with respect to the wage rate (elasticity of supply with respect to the price of labor)**
- **and many, many others.**

Own-Price Elasticity of Demand

- **Q: Why not use a demand curve's slope to measure the sensitivity of quantity demanded to a change in a commodity's own price?**

Own-Price Elasticity of Demand

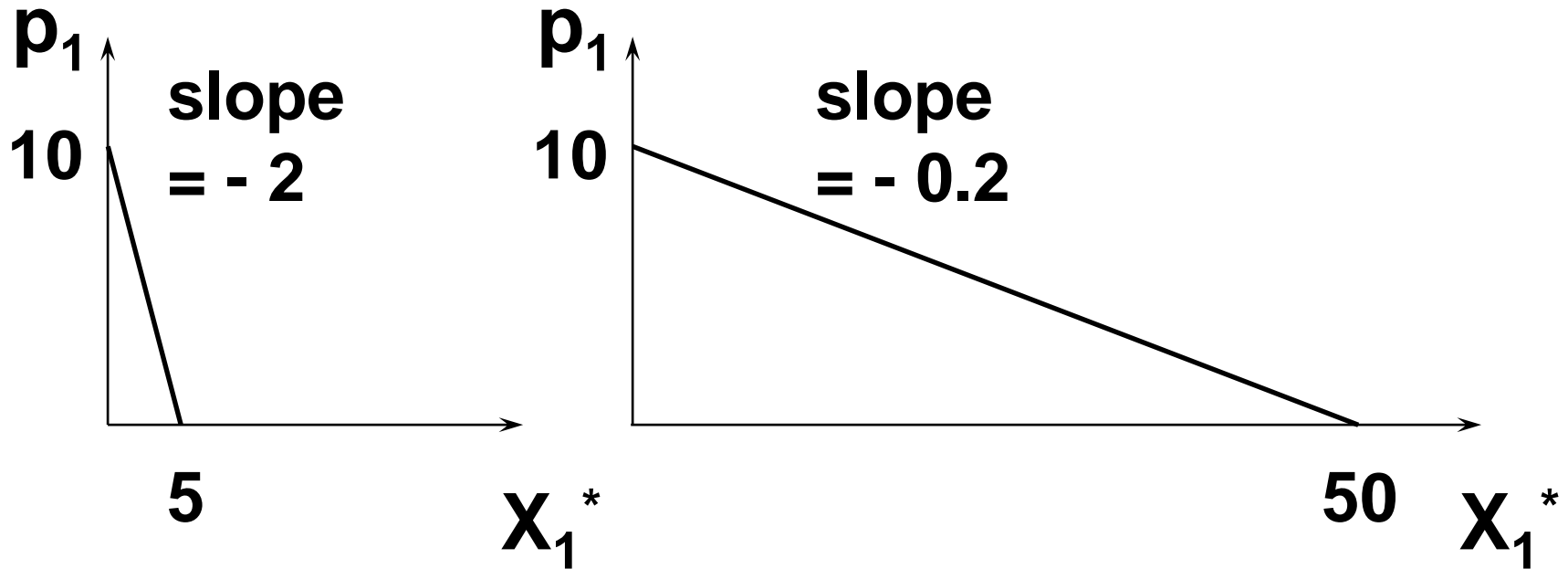

In which case is the quantity demanded X_1^* more sensitive to changes to p_1 ?

Own-Price Elasticity of Demand

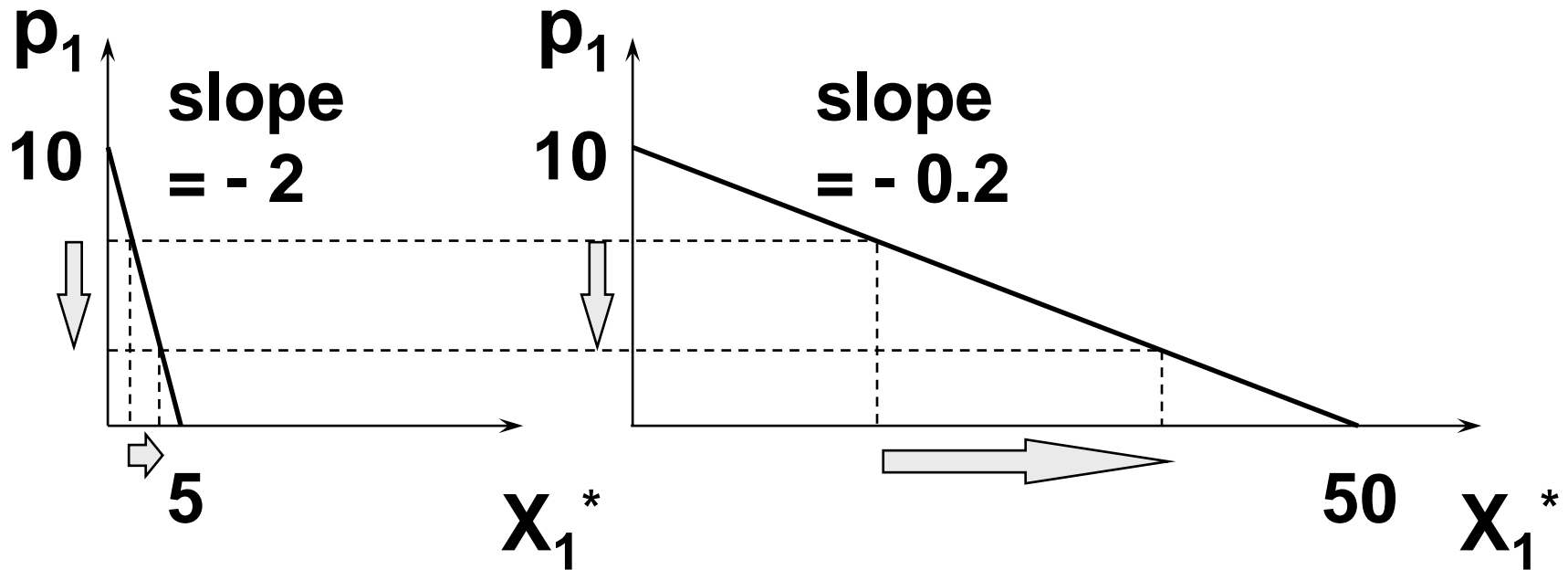

In which case is the quantity demanded X_1^* more sensitive to changes to p_1 ?

Own-Price Elasticity of Demand

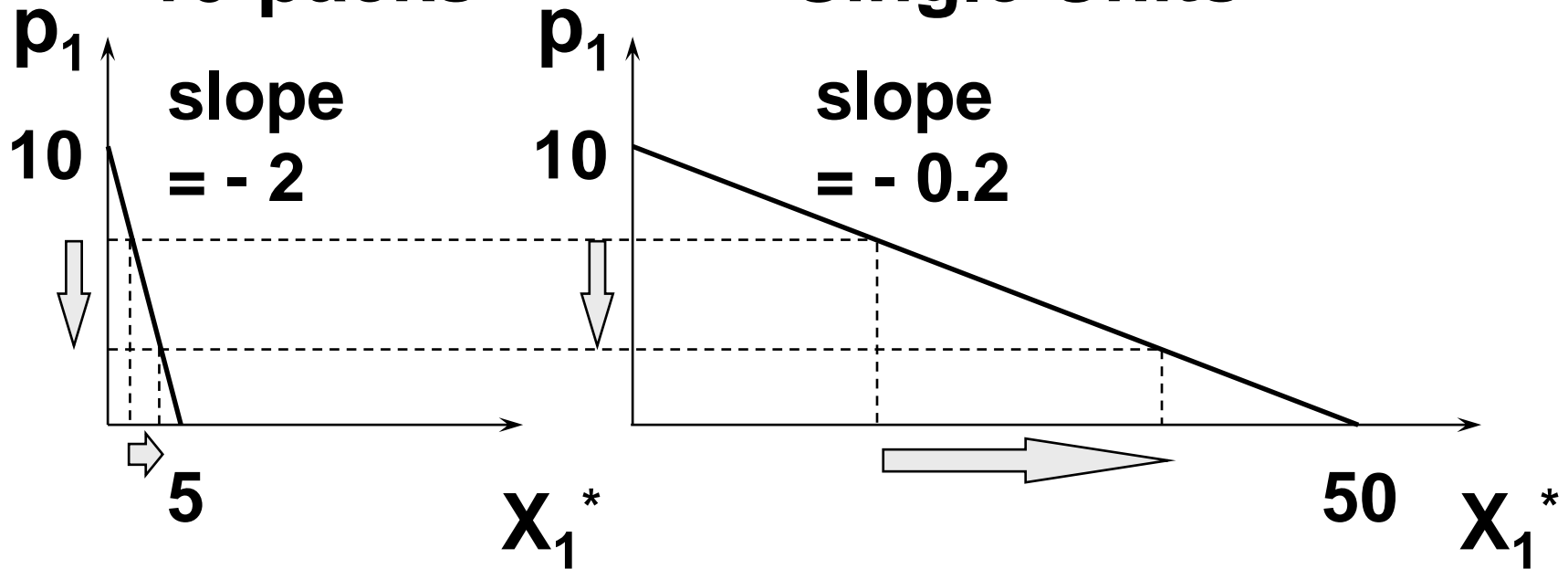

In which case is the quantity demanded X_1^* more sensitive to changes to p_1 ?

Own-Price Elasticity of Demand

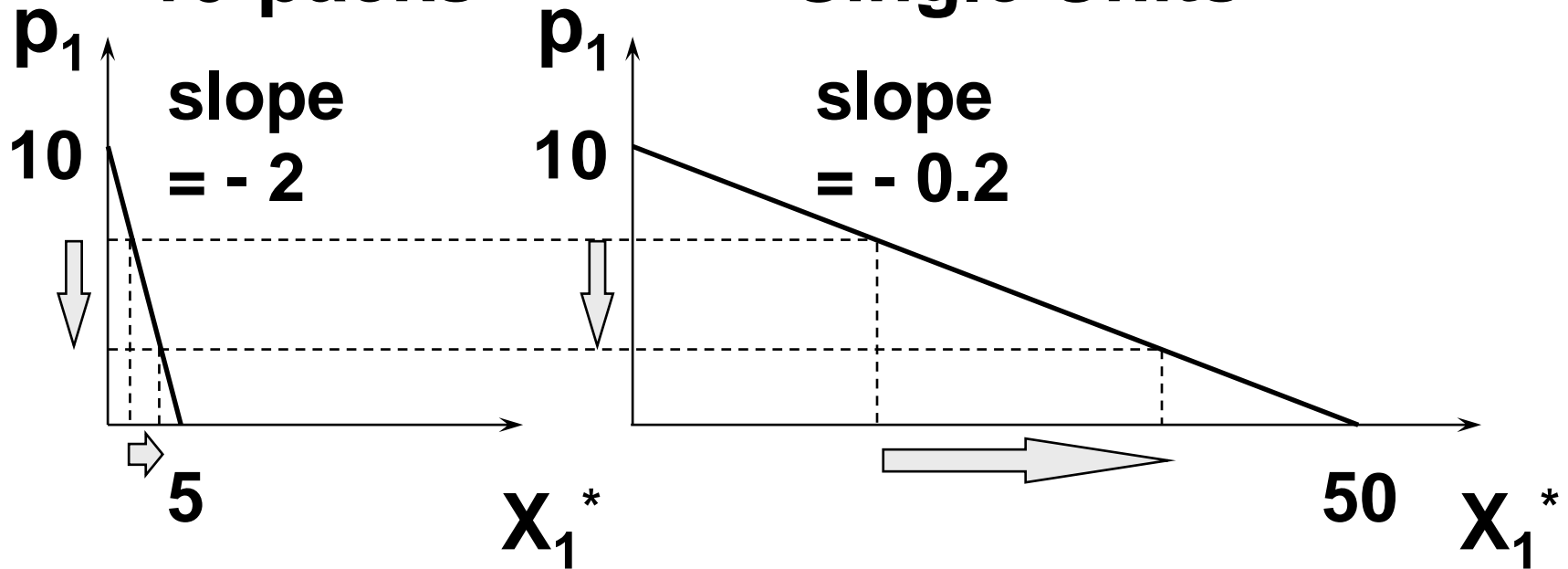

In which case is the quantity demanded X_1^* more sensitive to changes to p_1 ?
It is the same in both cases.

Own-Price Elasticity of Demand

- **Q: Why not just use the slope of a demand curve to measure the sensitivity of quantity demanded to a change in a commodity's own price?**
- **A: Because the value of sensitivity then depends upon the (arbitrary) units of measurement used for quantity demanded.**

Own-Price Elasticity of Demand

$$\varepsilon_{x_1, p_1}^* = \frac{\% \Delta x_1^*}{\% \Delta p_1}$$

is a ratio of percentages and so has no units of measurement.

Hence own-price elasticity of demand is a sensitivity measure that is independent of units of measurement.

Arc and Point Elasticities

- **An “average” own-price elasticity of demand for commodity i over an interval of values for p_i is an arc-elasticity, usually computed by a mid-point formula.**
- **Elasticity computed for a single value of p_i is a point elasticity.**

Arc Own-Price Elasticity

What is the “average” own-price elasticity of demand for prices in an interval centered on p_i' ?

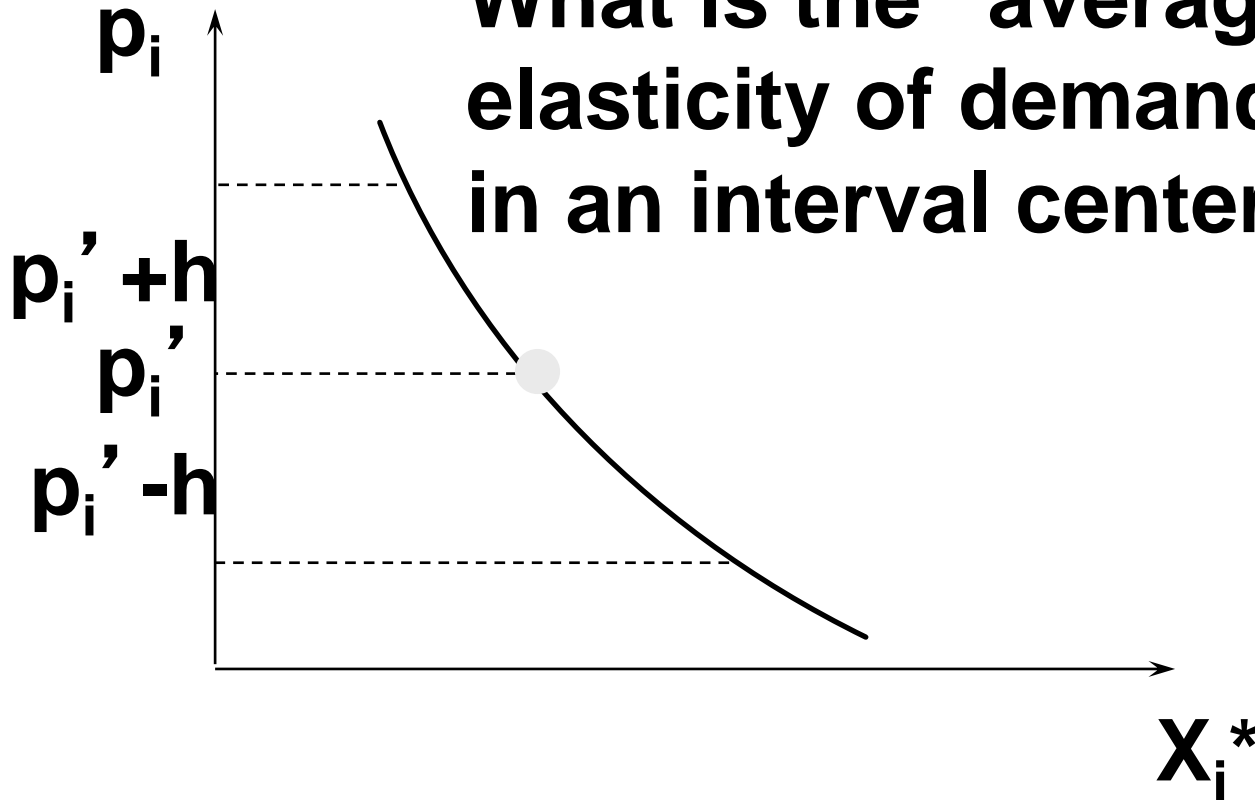

Arc Own-Price Elasticity

What is the “average” own-price elasticity of demand for prices in an interval centered on p_i' ?

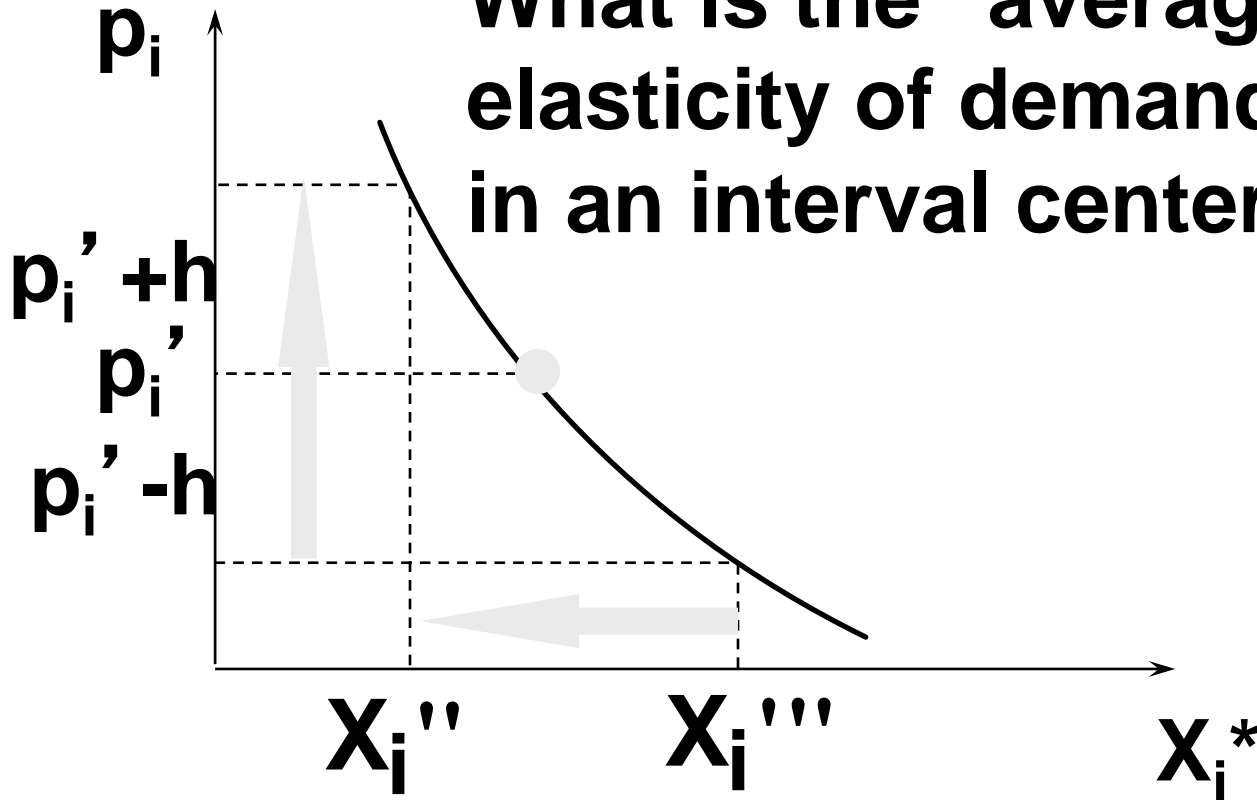

Arc Own-Price Elasticity

What is the “average” own-price elasticity of demand for prices in an interval centered on p_i' ?

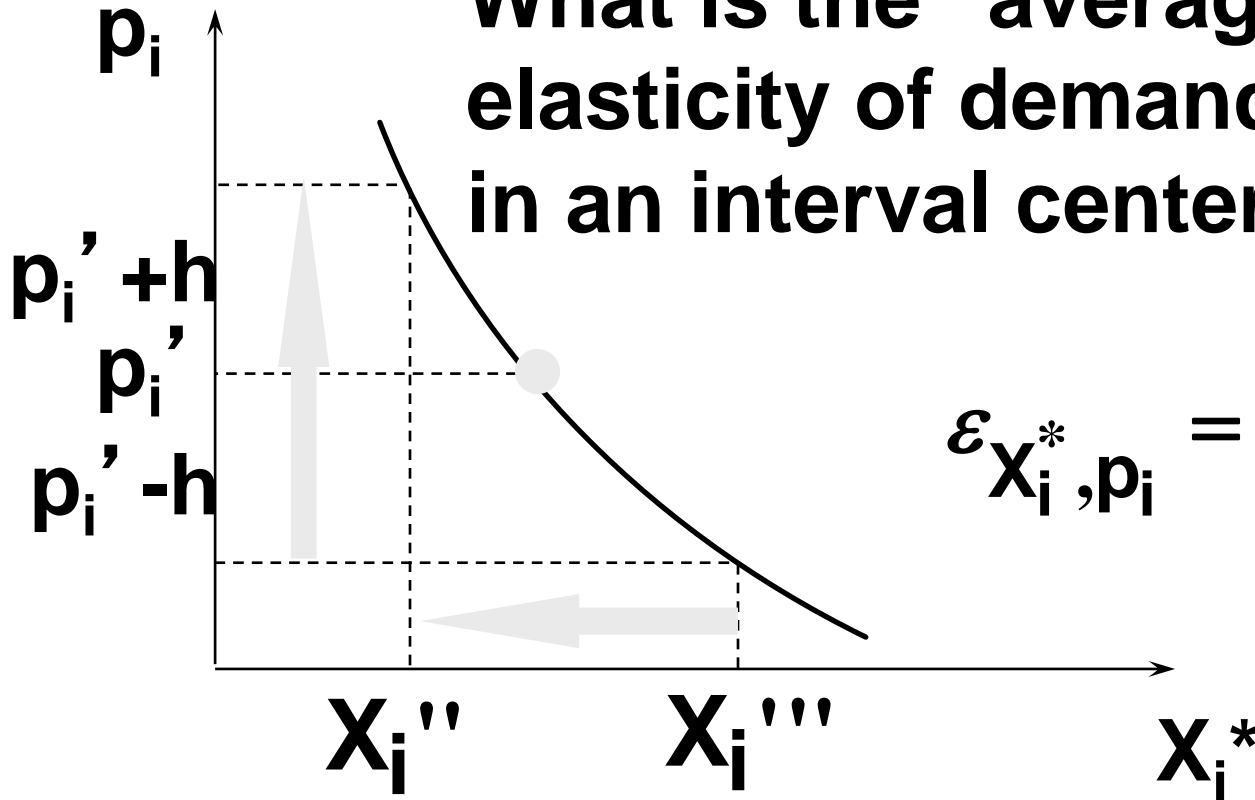

$$\varepsilon_{X_i^*, p_i} = \frac{\% \Delta X_i^*}{\% \Delta p_i}$$

Arc Own-Price Elasticity

What is the “average” own-price elasticity of demand for prices in an interval centered on p_i' ?

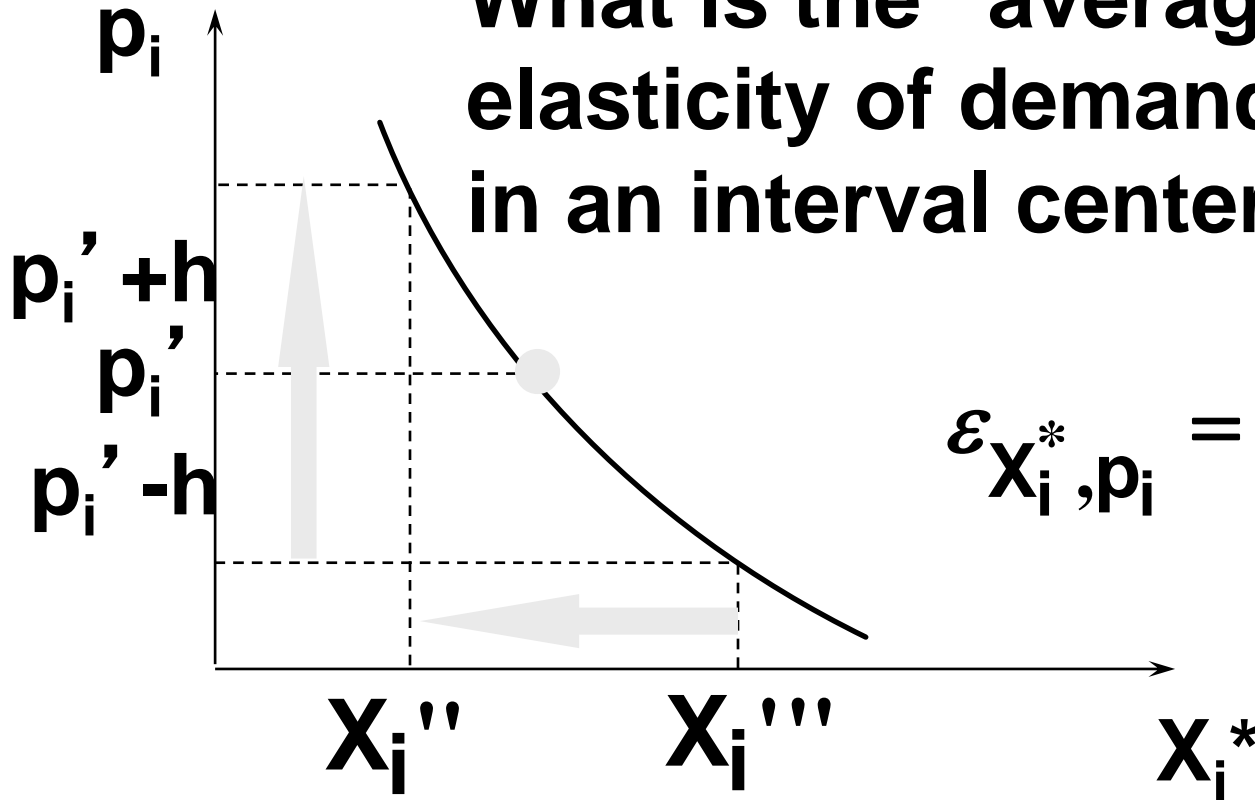

$$\varepsilon_{X_i^*, p_i}^* = \frac{\% \Delta X_i^*}{\% \Delta p_i}$$

$$\% \Delta p_i = 100 \times \frac{2h}{p_i'}$$

Arc Own-Price Elasticity

What is the “average” own-price elasticity of demand for prices in an interval centered on p_i' ?

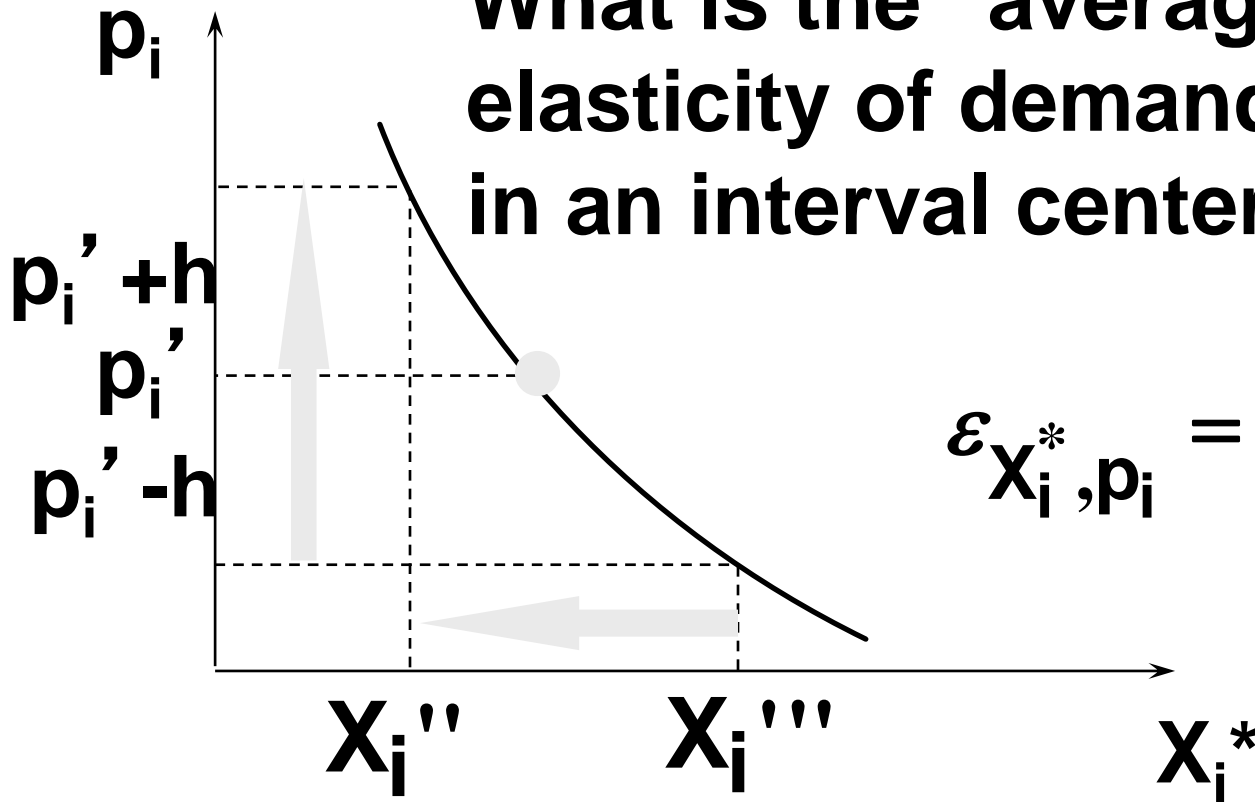

$$\varepsilon_{X_i^*, p_i} = \frac{\% \Delta X_i^*}{\% \Delta p_i}$$

$$\% \Delta p_i = 100 \times \frac{2h}{p_i'} \quad \% \Delta X_i^* = 100 \times \frac{(X_i'' - X_i''')}{(X_i'' + X_i''') / 2}$$

Arc Own-Price Elasticity

$$\% \Delta p_i = 100 \times \frac{2h}{p_i'}$$

$$\varepsilon_{X_i^*, p_i} = \frac{\% \Delta X_i^*}{\% \Delta p_i}$$

$$\% \Delta X_i^* = 100 \times \frac{(X_i'' - X_i''')}{(X_i'' + X_i''') / 2}$$

Arc Own-Price Elasticity

$$\% \Delta p_i = 100 \times \frac{2h}{p_i'}$$

$$\varepsilon_{X_i^*, p_i} = \frac{\% \Delta X_i^*}{\% \Delta p_i}$$

$$\% \Delta X_i^* = 100 \times \frac{(X_i'' - X_i''')}{(X_i'' + X_i''') / 2}$$

So

$$\varepsilon_{X_i^*, p_i} = \frac{\% \Delta X_i^*}{\% \Delta p_i} = \frac{p_i'}{(X_i'' + X_i''') / 2} \times \frac{(X_i'' - X_i''')}{2h}.$$

is the arc own-price elasticity of demand.

Point Own-Price Elasticity

What is the own-price elasticity of demand in a very small interval of prices centered on p_i' ?

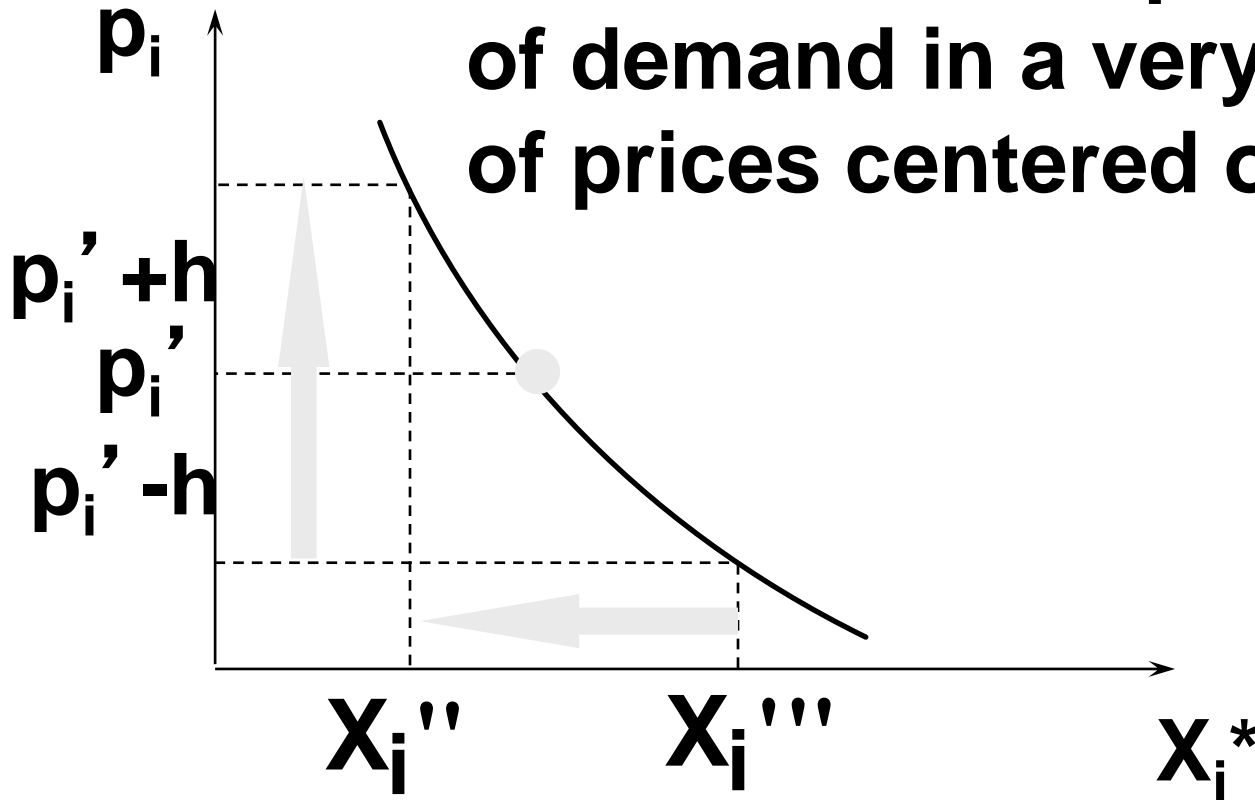

$$\epsilon_{X_i^*, p_i} = \frac{\% \Delta X_i^*}{\% \Delta p_i} = \frac{p_i'}{(X_i'' + X_i''')/2} \times \frac{(X_i'' - X_i''')}{2h}.$$

Point Own-Price Elasticity

What is the own-price elasticity of demand in a very small interval of prices centered on p_i' ?

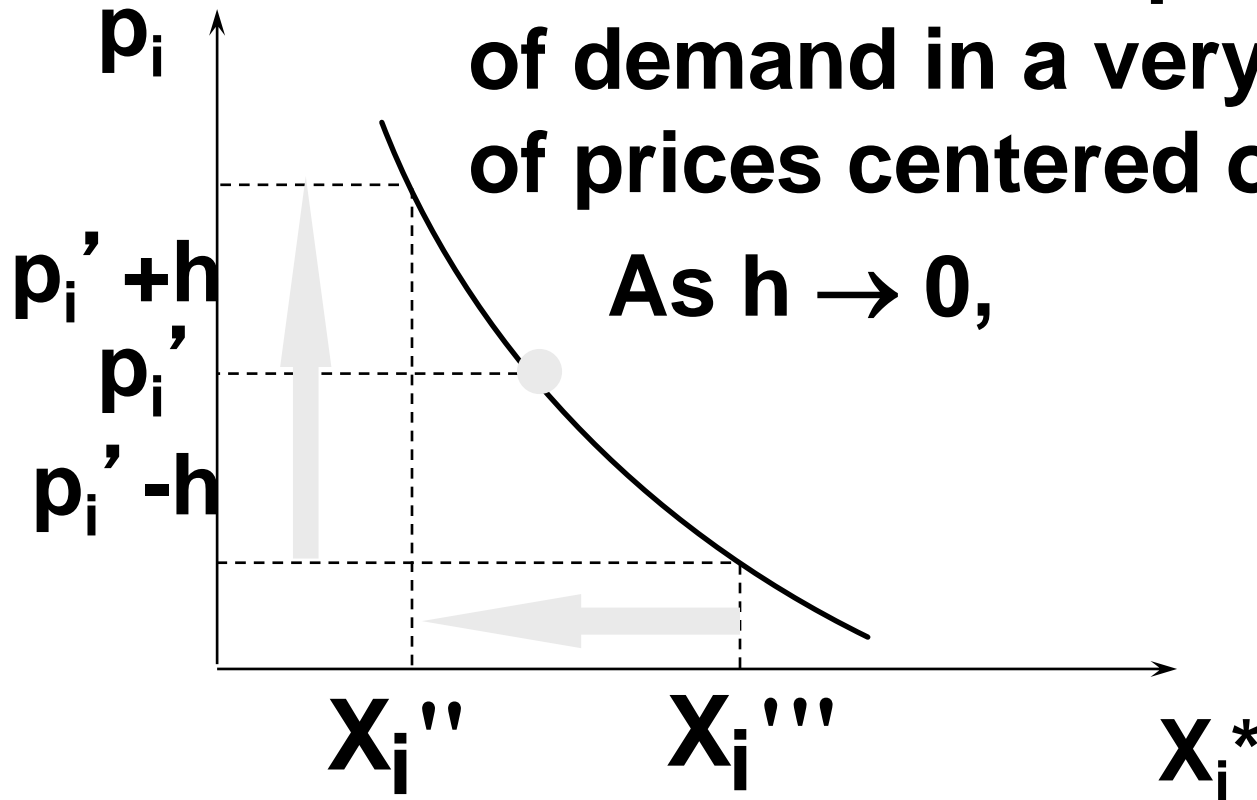

$$\epsilon_{X_i^*, p_i} = \frac{\% \Delta X_i^*}{\% \Delta p_i} = \frac{p_i'}{(X_i'' + X_i''')/2} \times \frac{(X_i'' - X_i''')}{2h}.$$

Point Own-Price Elasticity

What is the own-price elasticity of demand in a very small interval of prices centered on p_i' ?

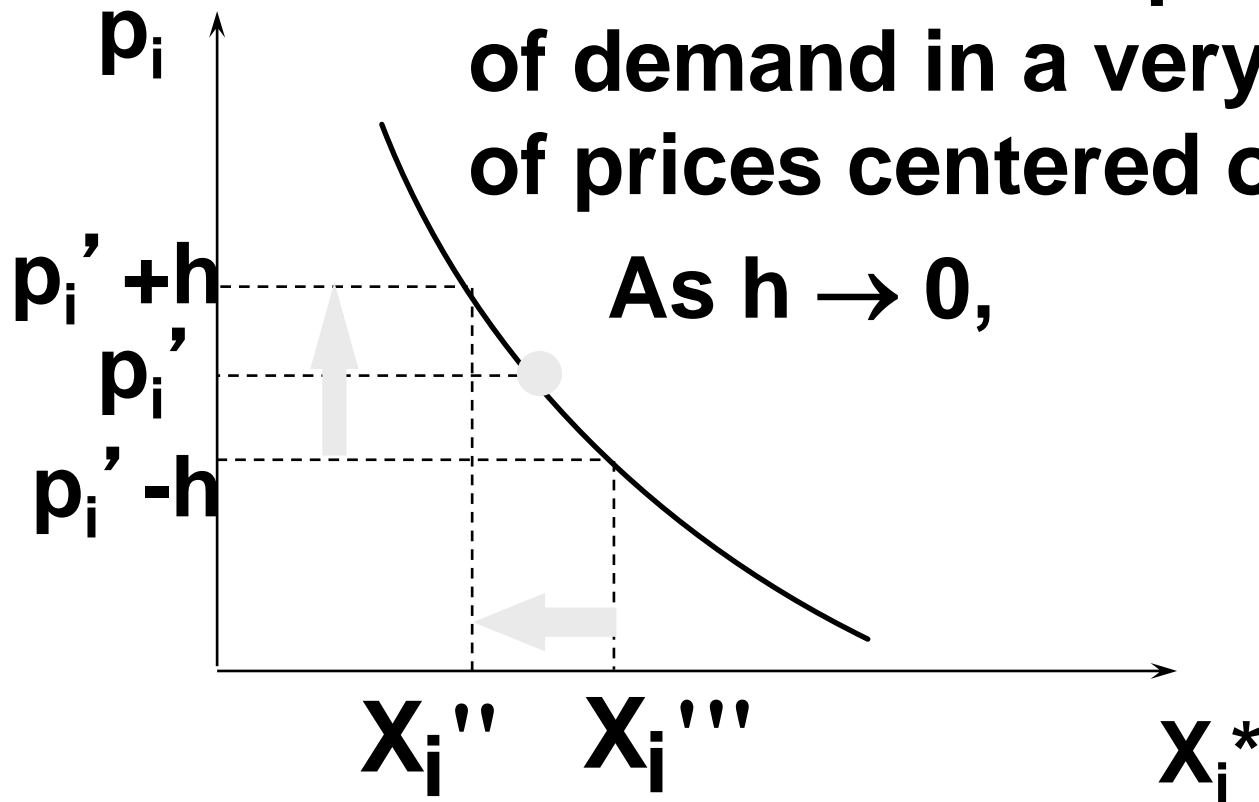

$$\epsilon_{X_i^*, p_i} = \frac{\% \Delta X_i^*}{\% \Delta p_i} = \frac{p_i'}{(X_i'' + X_i''')/2} \times \frac{(X_i'' - X_i''')}{2h}.$$

Point Own-Price Elasticity

What is the own-price elasticity of demand in a very small interval of prices centered on p_i' ?

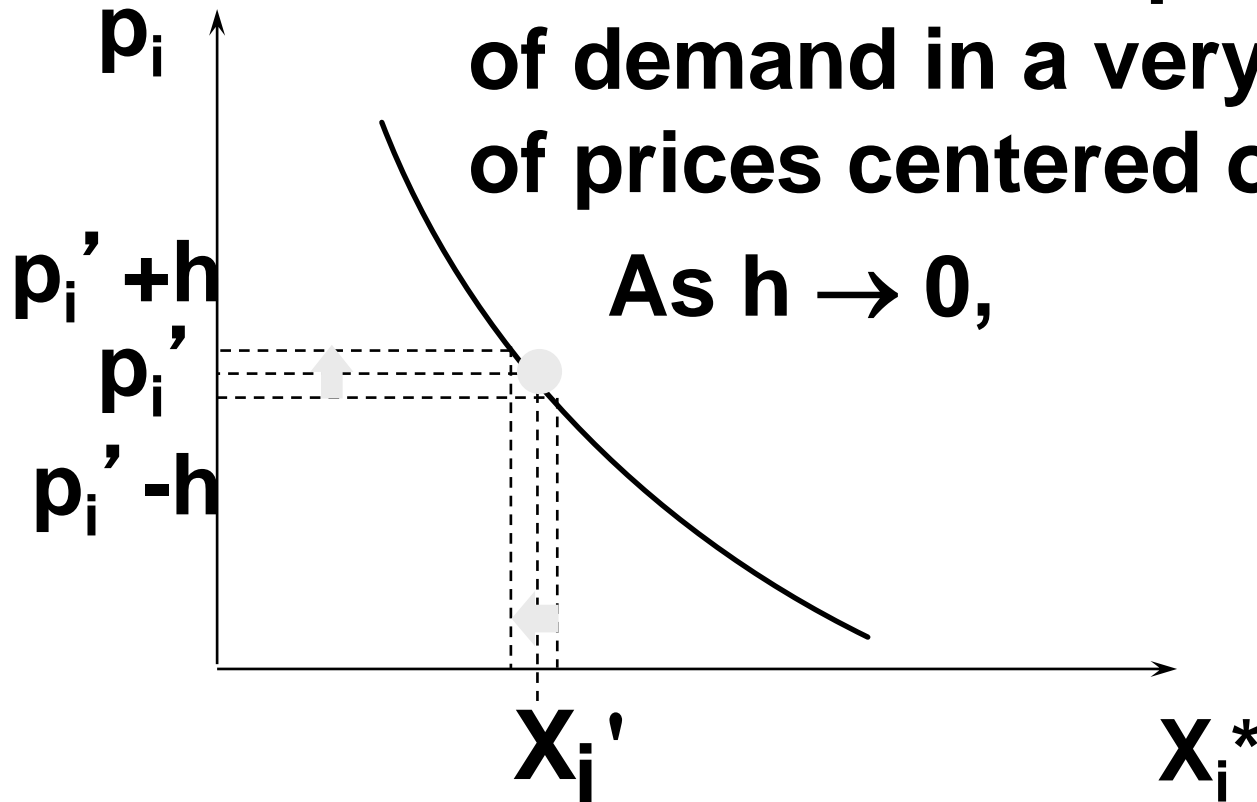

$$\epsilon_{X_i^*, p_i} = \frac{\% \Delta X_i^*}{\% \Delta p_i} = \frac{p_i'}{(X_i'' + X_i''')/2} \times \frac{(X_i'' - X_i''')}{2h}.$$

Point Own-Price Elasticity

What is the own-price elasticity of demand in a very small interval of prices centered on p_i' ?

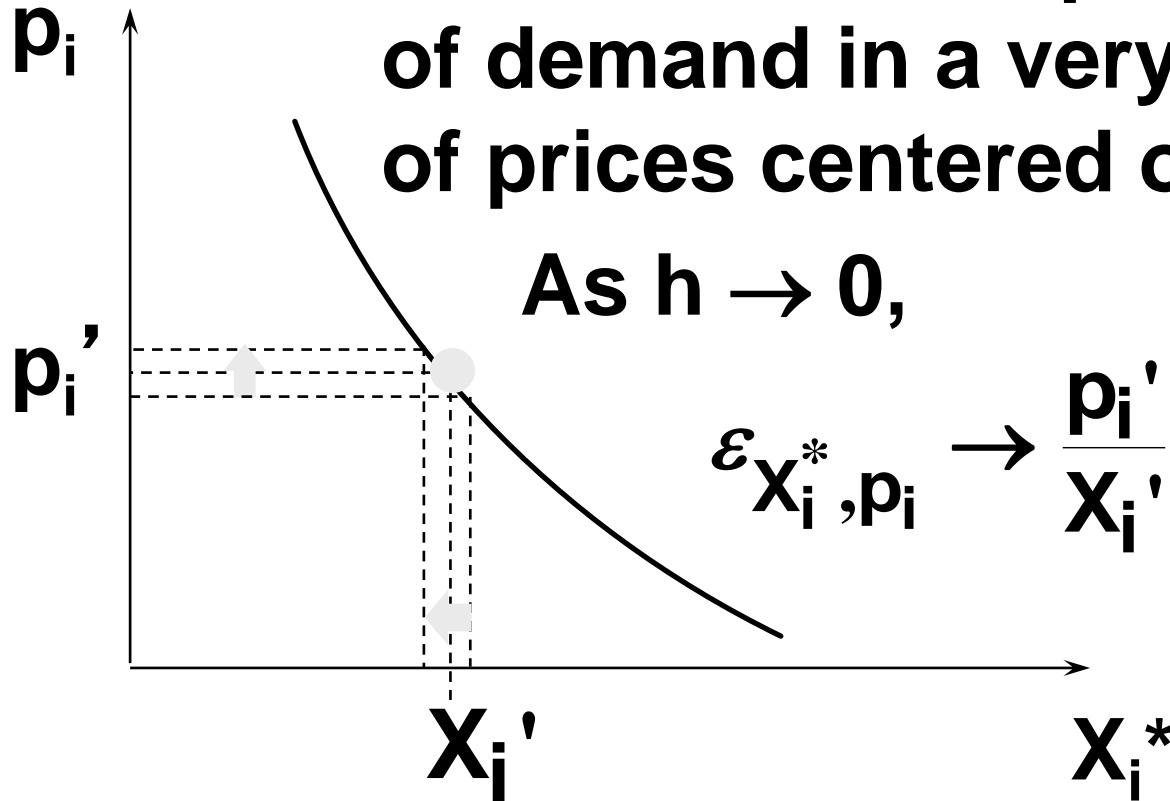

$$\epsilon_{X_i^*, p_i} \rightarrow \frac{p_i'}{X_i'} \times \frac{dX_i^*}{dp_i}$$

$$\epsilon_{X_i^*, p_i} = \frac{\% \Delta X_i^*}{\% \Delta p_i} = \frac{p_i'}{(X_i'' + X_i''')/2} \times \frac{(X_i'' - X_i''')}{2h}$$

Point Own-Price Elasticity

What is the own-price elasticity of demand in a very small interval of prices centered on p_i' ?

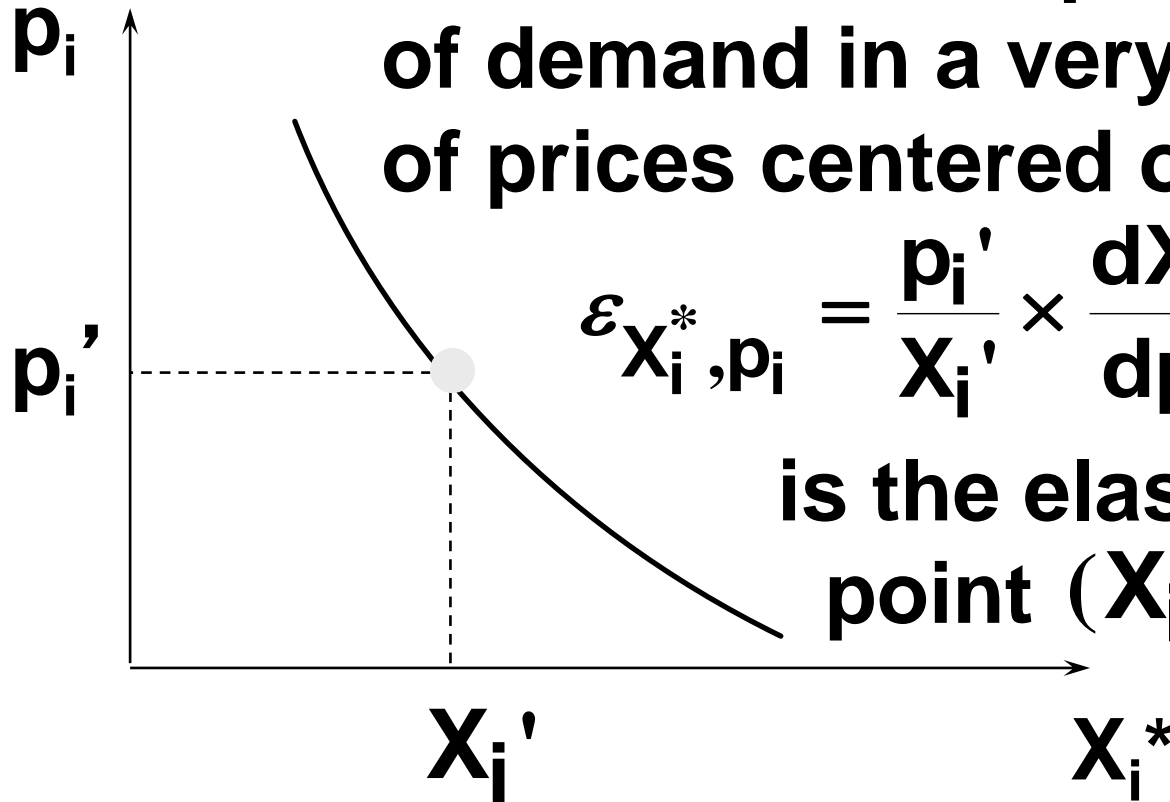

$$\epsilon_{X_i^*, p_i} = \frac{p_i'}{X_i'} \times \frac{dX_i^*}{dp_i}$$

is the elasticity at the point (X_i', p_i') .

Point Own-Price Elasticity

$$\varepsilon_{X_i^*, p_i} = \frac{p_i}{X_i^*} \times \frac{dX_i^*}{dp_i}$$

E.g. Suppose $p_i = a - bX_i$.

Then $X_i = (a - p_i)/b$ and

$$\frac{dX_i^*}{dp_i} = -\frac{1}{b}. \text{ Therefore,}$$

$$\varepsilon_{X_i^*, p_i} = \frac{p_i}{(a - p_i) / b} \times \left(-\frac{1}{b} \right) = -\frac{p_i}{a - p_i}.$$

Point Own-Price Elasticity

$$p_i = a - bX_i^*$$

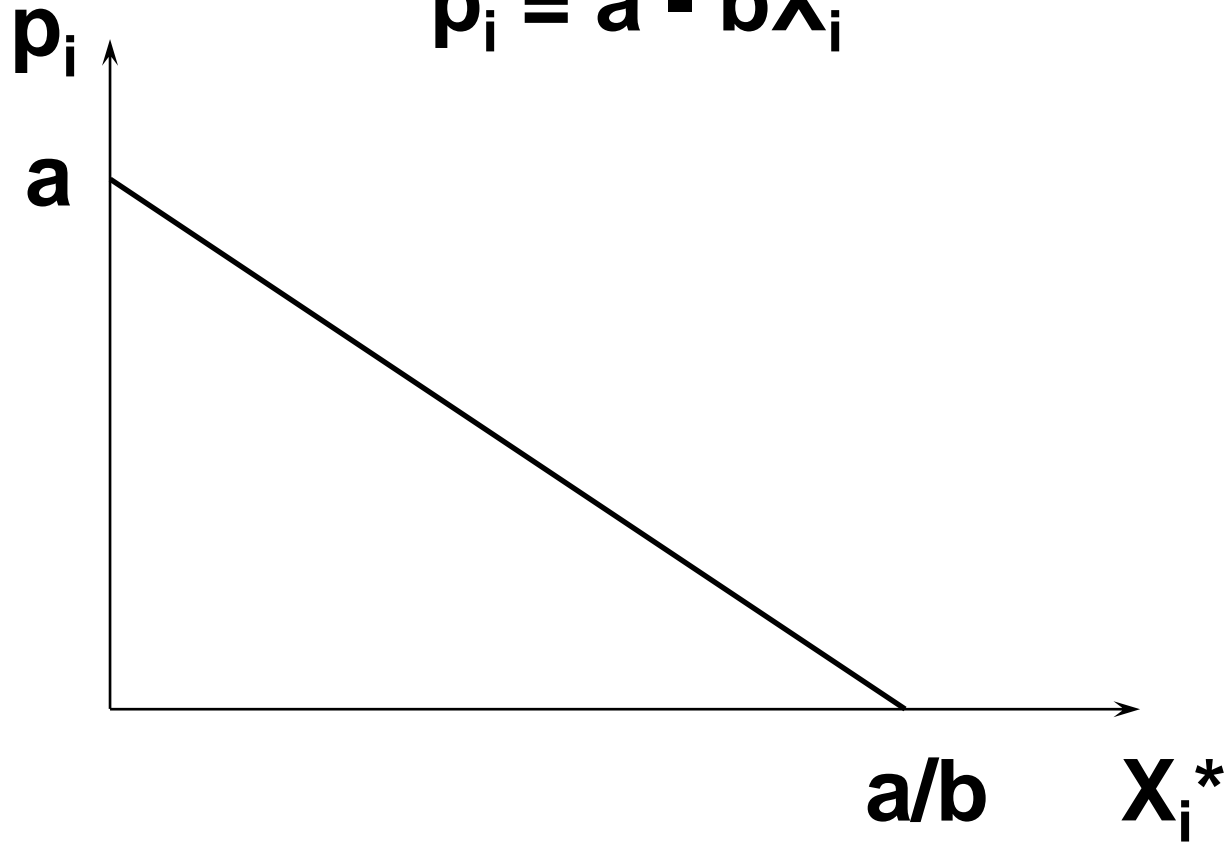

Point Own-Price Elasticity

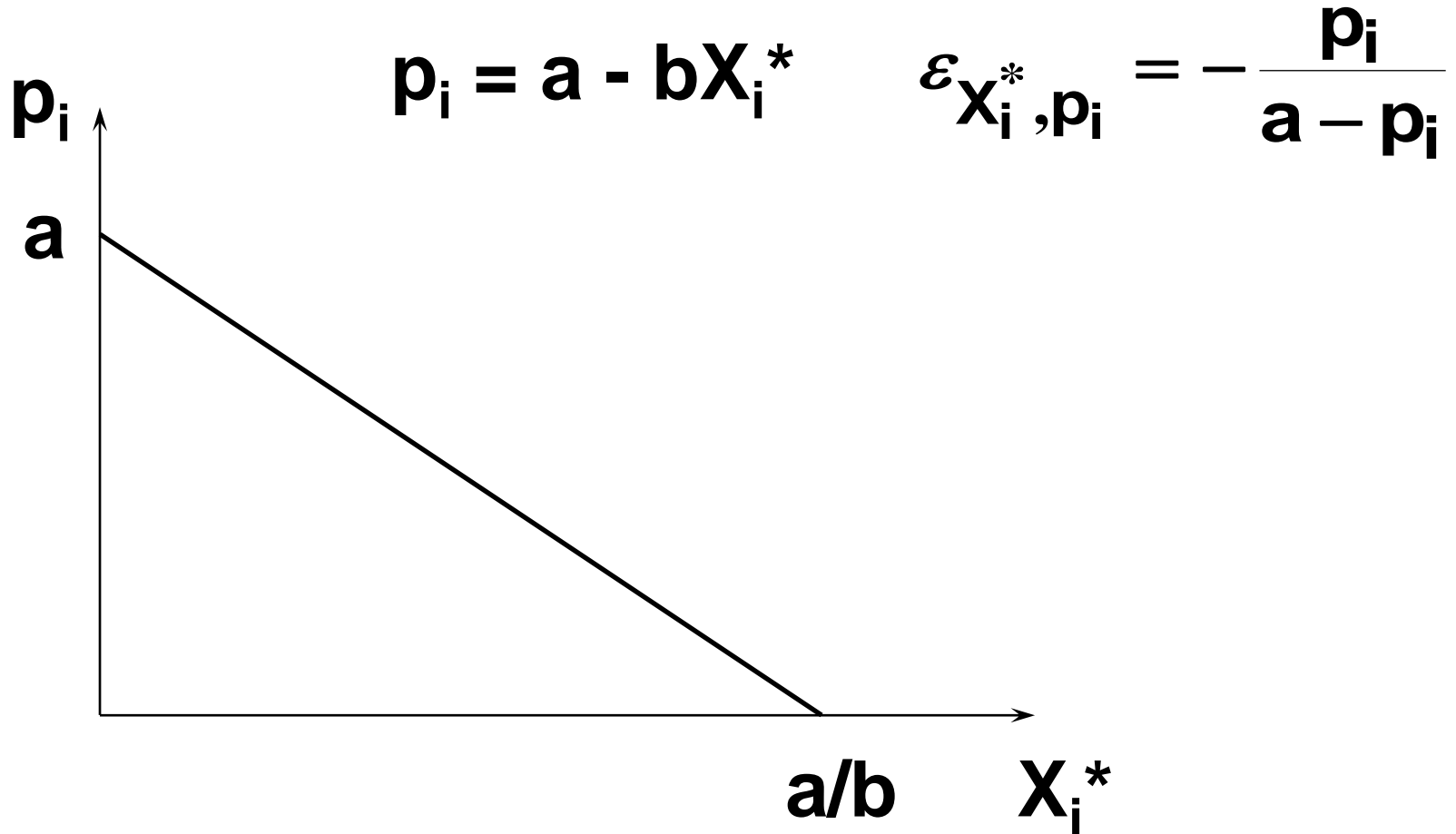

Point Own-Price Elasticity

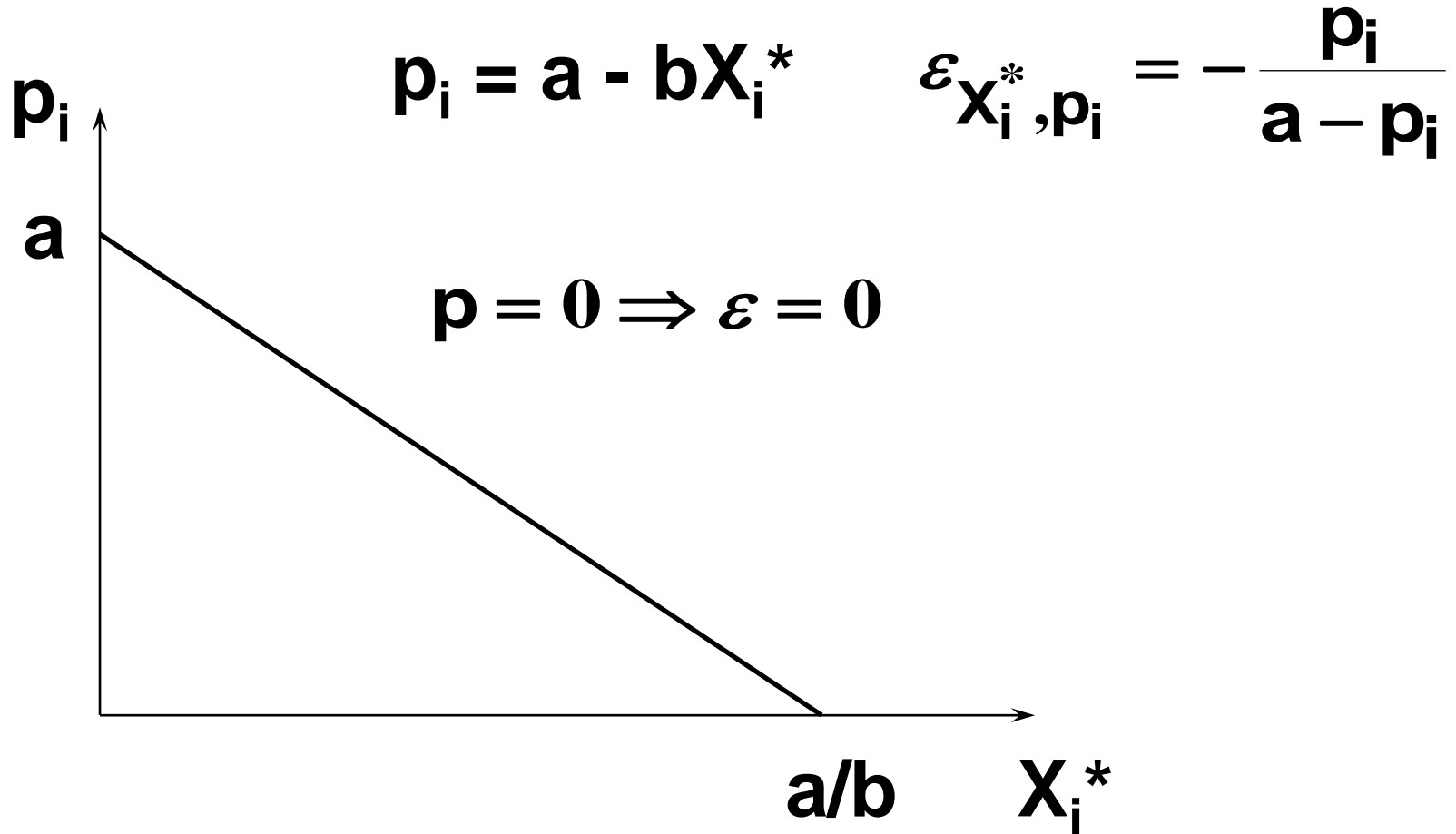

Point Own-Price Elasticity

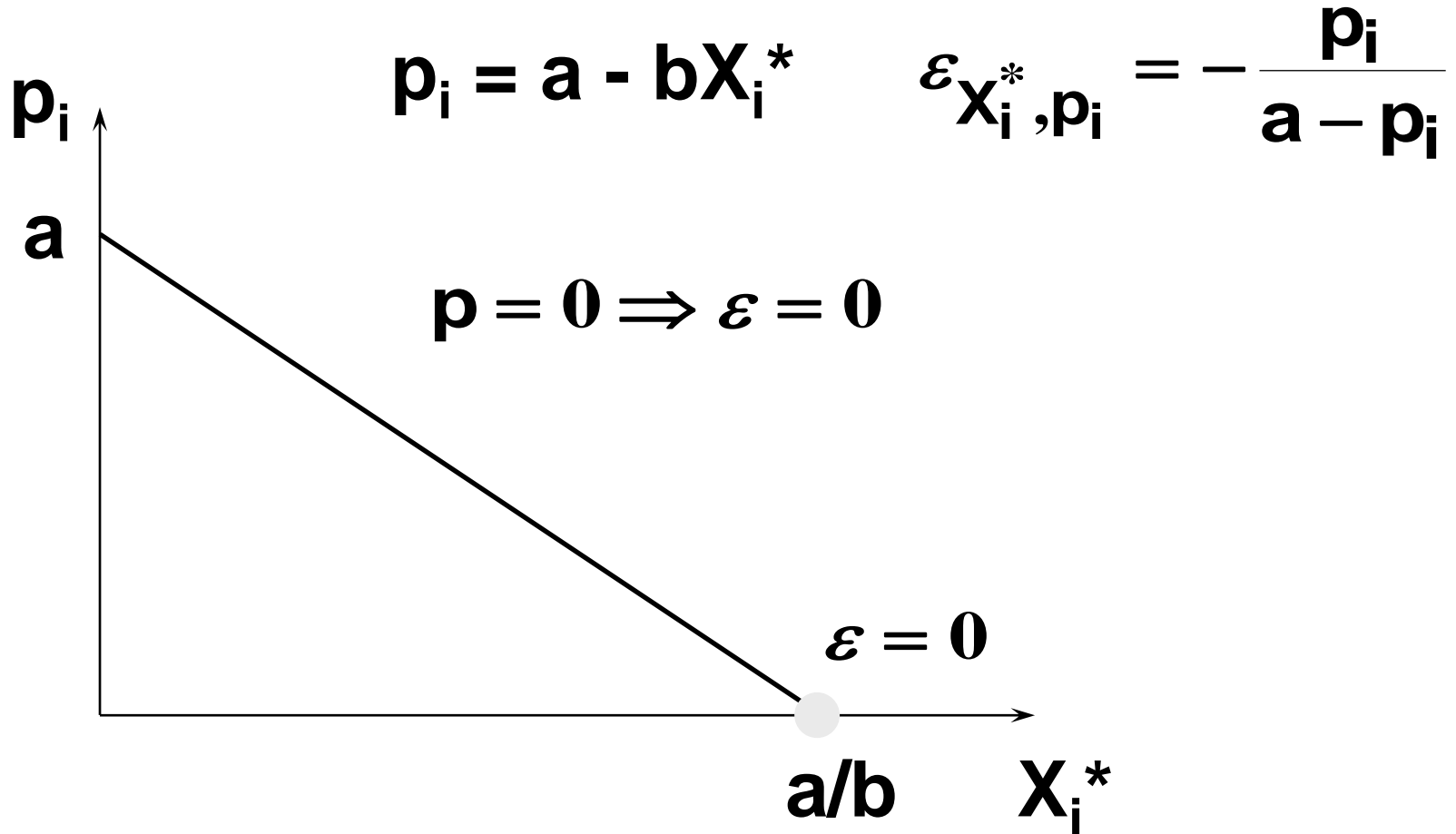

Point Own-Price Elasticity

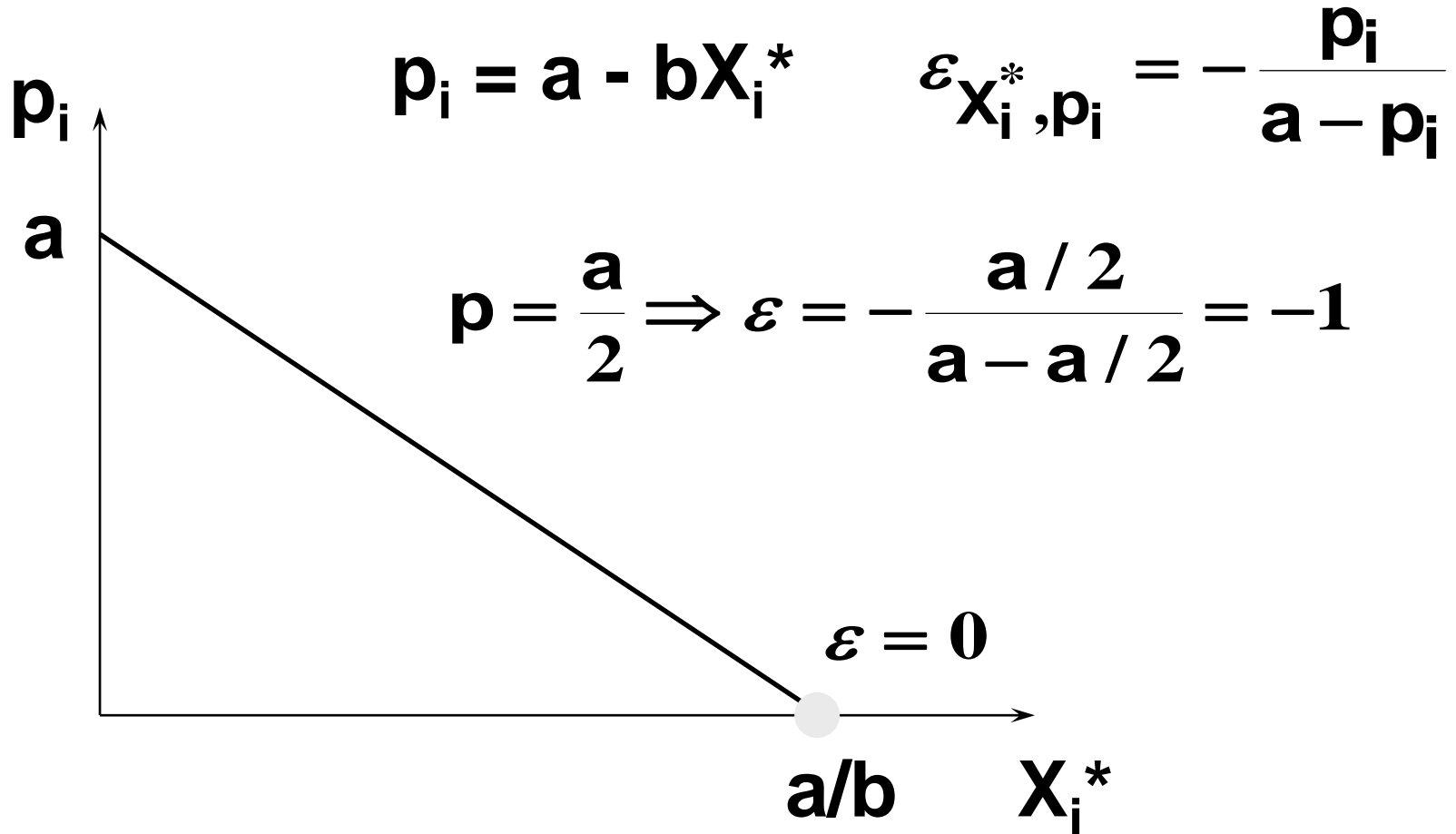

Point Own-Price Elasticity

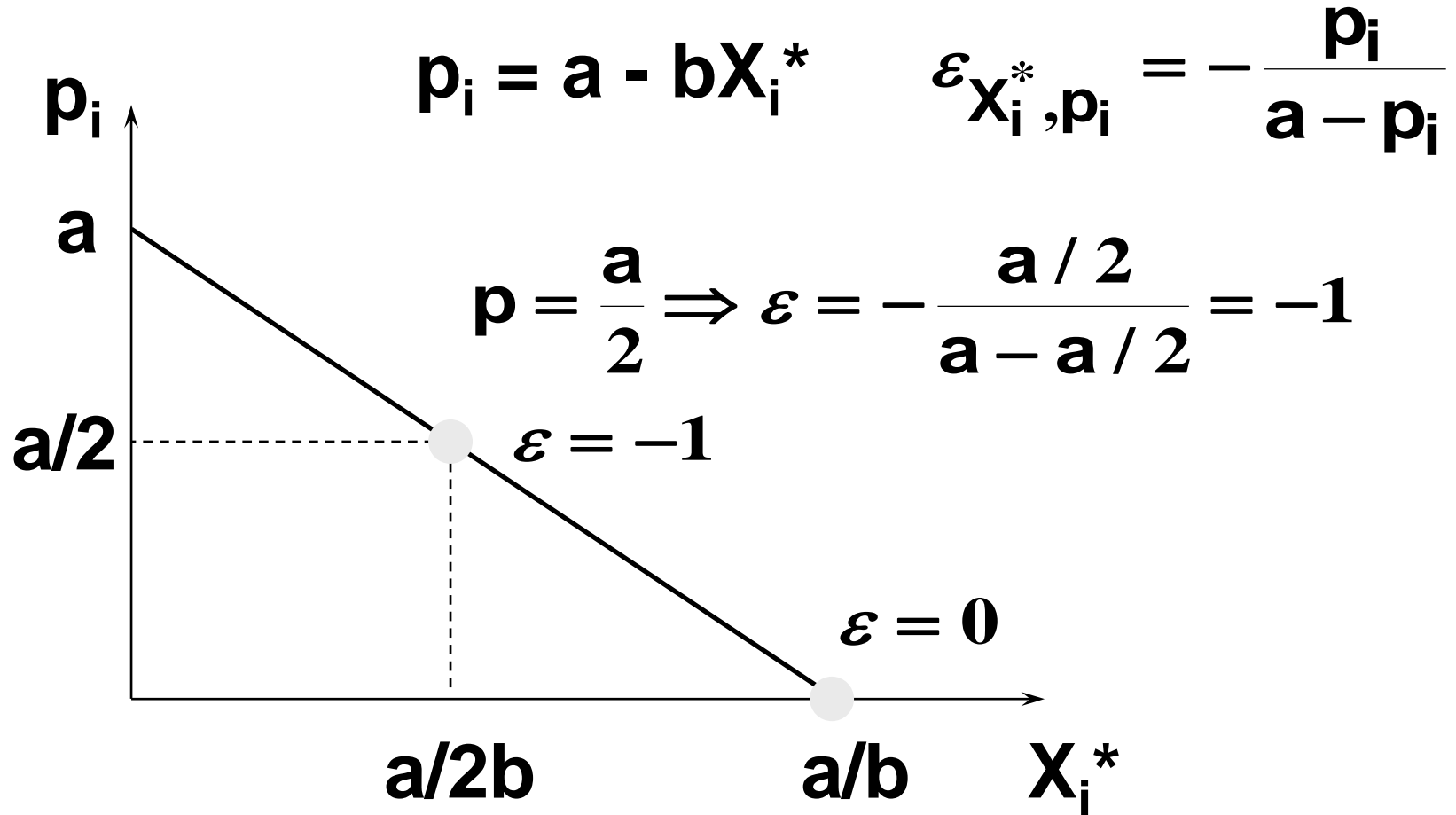

Point Own-Price Elasticity

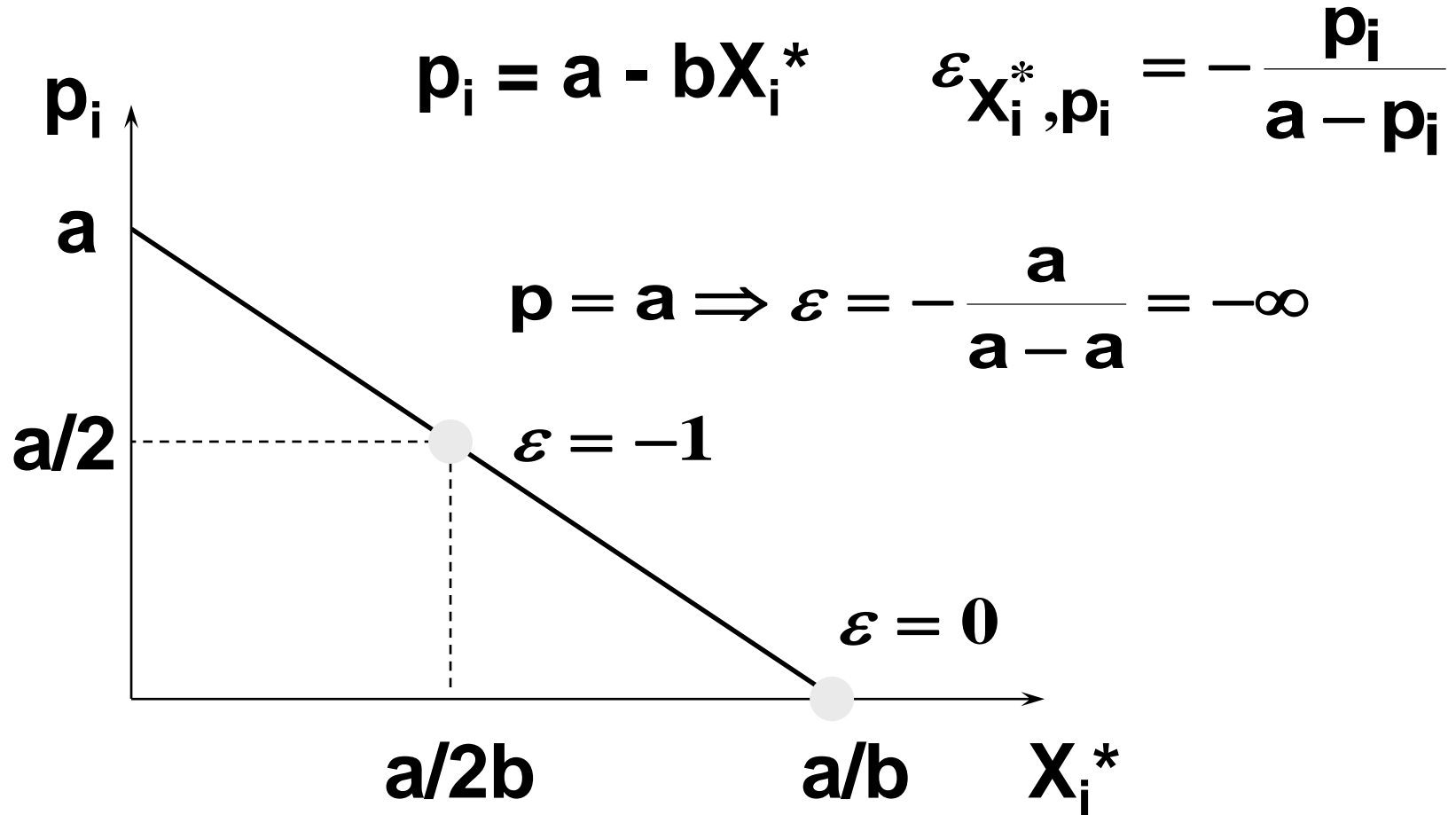

Point Own-Price Elasticity

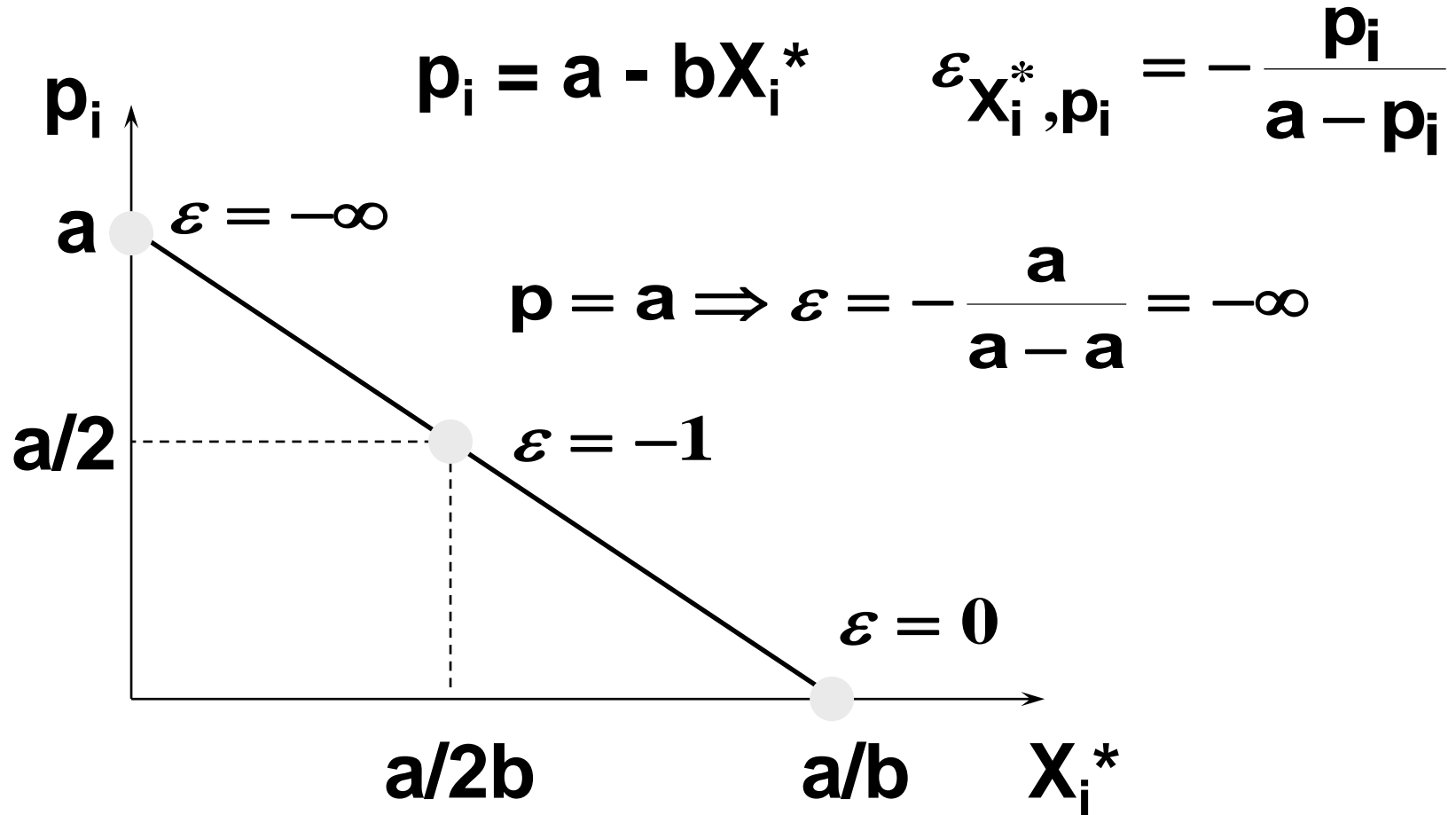

Point Own-Price Elasticity

$$p_i = a - bX_i^* \quad \epsilon_{X_i^*, p_i} = -\frac{p_i}{a - p_i}$$

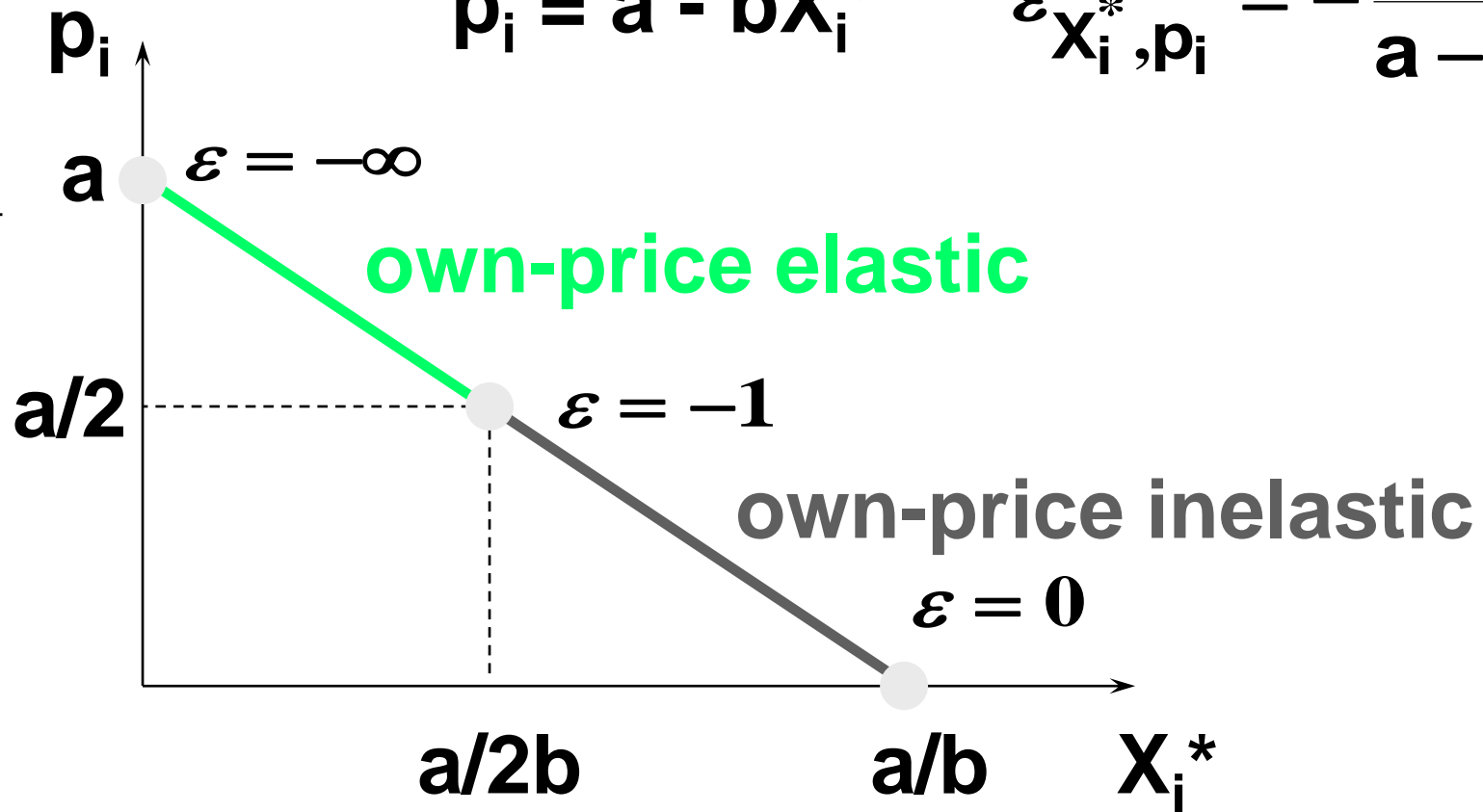

Point Own-Price Elasticity

$$p_i = a - bX_i^* \quad \epsilon_{X_i^*, p_i} = -\frac{p_i}{a - p_i}$$

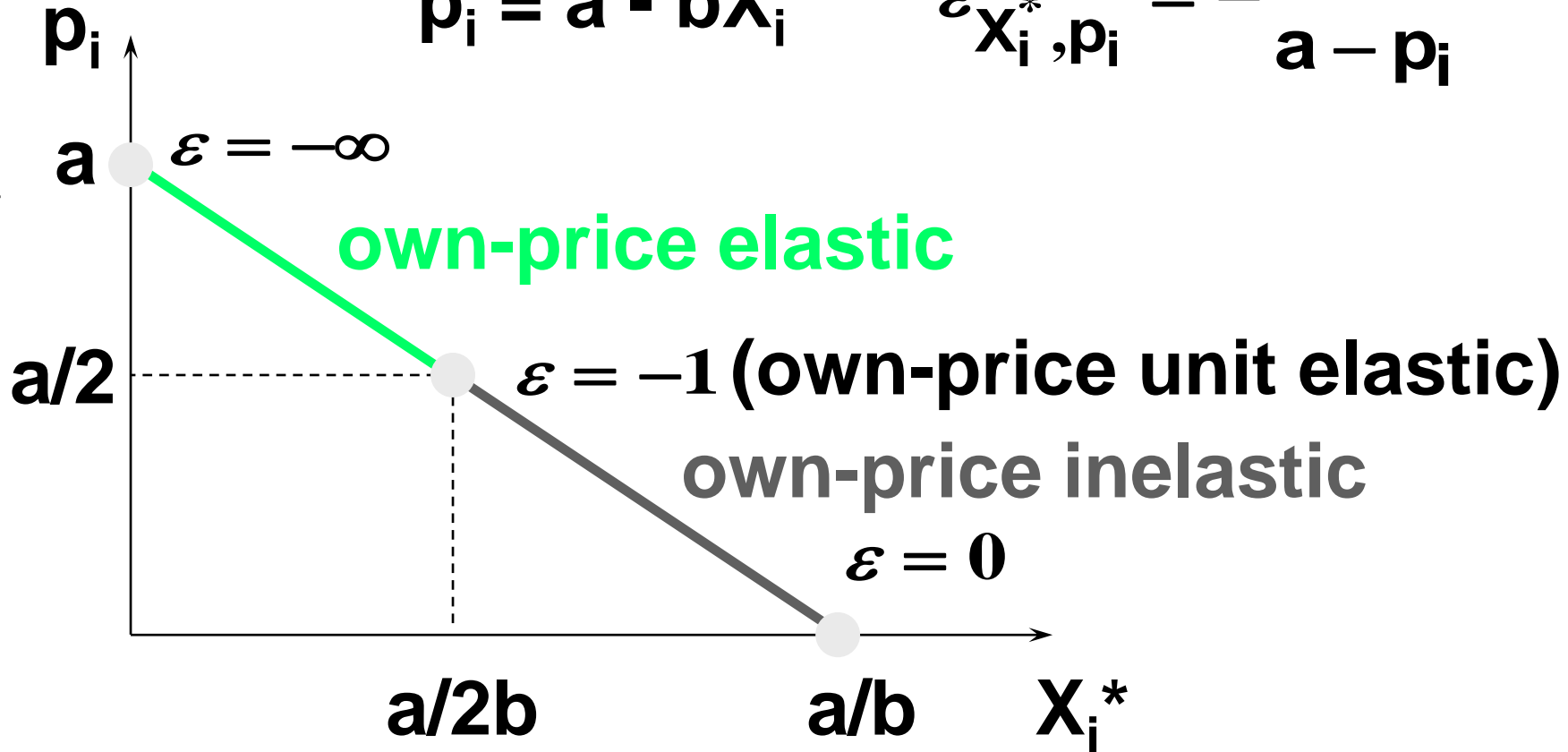

Point Own-Price Elasticity

$$\varepsilon_{X_i^*, p_i} = \frac{p_i}{X_i^*} \times \frac{dX_i^*}{dp_i}$$

E.g. $X_i^* = kp_i^a$. Then $\frac{dX_i^*}{dp_i} = ap_i^{a-1}$

so

$$\varepsilon_{X_i^*, p_i} = \frac{p_i}{kp_i^a} \times k a p_i^{a-1} = a \frac{p_i^a}{p_i^a} = a.$$

Point Own-Price Elasticity

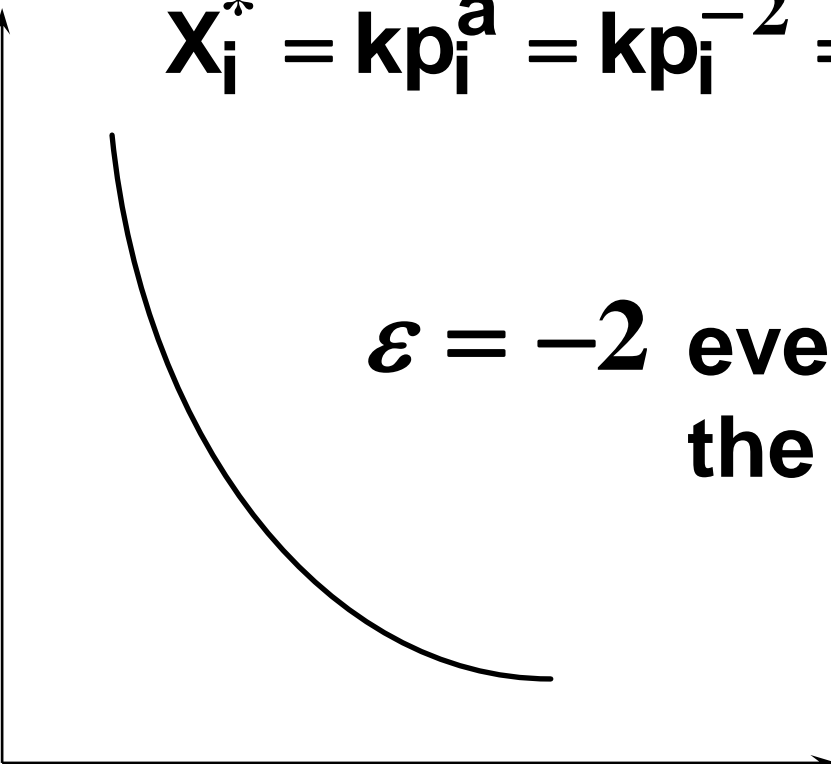
$$p_i \quad X_i^* = k p_i^a = k p_i^{-2} = \frac{k}{p_i^2}$$
A graph with a vertical axis labeled p_i and a horizontal axis labeled X_i^* . A smooth, downward-sloping curve starts high on the vertical axis and curves towards the horizontal axis, representing a demand curve.

$\varepsilon = -2$ everywhere along
the demand curve.

Revenue and Own-Price Elasticity of Demand

- **If raising a commodity's price causes little decrease in quantity demanded, then sellers' revenues rise.**
- **Hence own-price inelastic demand causes sellers' revenues to rise as price rises.**

Revenue and Own-Price Elasticity of Demand

- **If raising a commodity's price causes a large decrease in quantity demanded, then sellers' revenues fall.**
- **Hence own-price elastic demand causes sellers' revenues to fall as price rises.**

Revenue and Own-Price

Elasticity of Demand

Sellers' revenue is $R(p) = p \times X^*(p)$.

Revenue and Own-Price

Elasticity of Demand

Sellers' revenue is $R(p) = p \times X^*(p)$.

So $\frac{dR}{dp} = X^*(p) + p \frac{dX^*}{dp}$

Revenue and Own-Price Elasticity of Demand

Sellers' revenue is $R(p) = p \times X^*(p)$.

$$\begin{aligned}\text{So } \frac{dR}{dp} &= X^*(p) + p \frac{dX^*}{dp} \\ &= X^*(p) \left[1 + \frac{p}{X^*(p)} \frac{dX^*}{dp} \right]\end{aligned}$$

Revenue and Own-Price

Elasticity of Demand

Sellers' revenue is $R(p) = p \times X^*(p)$.

$$\begin{aligned}\text{So } \frac{dR}{dp} &= X^*(p) + p \frac{dX^*}{dp} \\ &= X^*(p) \left[1 + \frac{p}{X^*(p)} \frac{dX^*}{dp} \right] \\ &= X^*(p) [1 + \varepsilon].\end{aligned}$$

Revenue and Own-Price Elasticity of Demand

$$\frac{dR}{dp} = X^*(p)[1 + \varepsilon]$$

Revenue and Own-Price Elasticity of Demand

$$\frac{dR}{dp} = X^*(p)[1 + \varepsilon]$$

so if $\varepsilon = -1$ then $\frac{dR}{dp} = 0$

and a change to price does not alter
sellers' revenue.

Revenue and Own-Price Elasticity of Demand

$$\frac{dR}{dp} = X^*(p)[1 + \varepsilon]$$

but if $-1 < \varepsilon \leq 0$ then $\frac{dR}{dp} > 0$

and a price increase raises sellers' revenue.

Revenue and Own-Price Elasticity of Demand

$$\frac{dR}{dp} = X^*(p)[1 + \varepsilon]$$

And if $\varepsilon < -1$ then $\frac{dR}{dp} < 0$

and a price increase reduces sellers' revenue.

Revenue and Own-Price Elasticity of Demand

In summary:

**Own-price inelastic demand; $-1 < \varepsilon \leq 0$
price rise causes rise in sellers' revenue.**

**Own-price unit elastic demand; $\varepsilon = -1$
price rise causes no change in sellers'
revenue.**

**Own-price elastic demand; $\varepsilon < -1$
price rise causes fall in sellers' revenue.**

Marginal Revenue and Own-Price Elasticity of Demand

- **A seller's marginal revenue is the rate at which revenue changes with the number of units sold by the seller.**

$$\mathbf{MR(q) = \frac{dR(q)}{dq} .}$$

Marginal Revenue and Own-Price Elasticity of Demand

$p(q)$ denotes the seller's inverse demand function; i.e. the price at which the seller can sell q units. Then

$$R(q) = p(q) \times q$$

so

$$\begin{aligned} MR(q) &= \frac{dR(q)}{dq} = \frac{dp(q)}{dq} q + p(q) \\ &= p(q) \left[1 + \frac{q}{p(q)} \frac{dp(q)}{dq} \right]. \end{aligned}$$

Marginal Revenue and Own-Price Elasticity of Demand

$$\mathbf{MR(q) = p(q) \left[1 + \frac{q}{p(q)} \frac{dp(q)}{dq} \right].}$$

and $\mathbf{\varepsilon = \frac{dq}{dp} \times \frac{p}{q}}$

so $\mathbf{MR(q) = p(q) \left[1 + \frac{1}{\varepsilon} \right].}$

Marginal Revenue and Own-Price Elasticity of Demand

$$\mathbf{MR(q) = p(q) \left[1 + \frac{1}{\varepsilon} \right]}$$
 says that the rate

at which a seller's revenue changes with the number of units it sells depends on the sensitivity of quantity demanded to price; *i.e.*, upon the of the own-price elasticity of demand.

Marginal Revenue and Own-Price Elasticity of Demand

$$\mathbf{MR(q) = p(q) \left[1 + \frac{1}{\varepsilon} \right]}$$

If $\varepsilon = -1$ then $MR(q) = 0$.

If $-1 < \varepsilon \leq 0$ then $MR(q) < 0$.

If $\varepsilon < -1$ then $MR(q) > 0$.

Marginal Revenue and Own-Price Elasticity of Demand

If $\varepsilon = -1$ then $MR(q) = 0$. Selling one more unit does not change the seller's revenue.

If $-1 < \varepsilon \leq 0$ then $MR(q) < 0$. Selling one more unit reduces the seller's revenue.

If $\varepsilon < -1$ then $MR(q) > 0$. Selling one more unit raises the seller's revenue.

Marginal Revenue and Own-Price Elasticity of Demand

An example with linear inverse demand.

$$p(q) = a - bq.$$

Then $R(q) = p(q)q = (a - bq)q$

and $MR(q) = a - 2bq.$

Marginal Revenue and Own-Price Elasticity of Demand

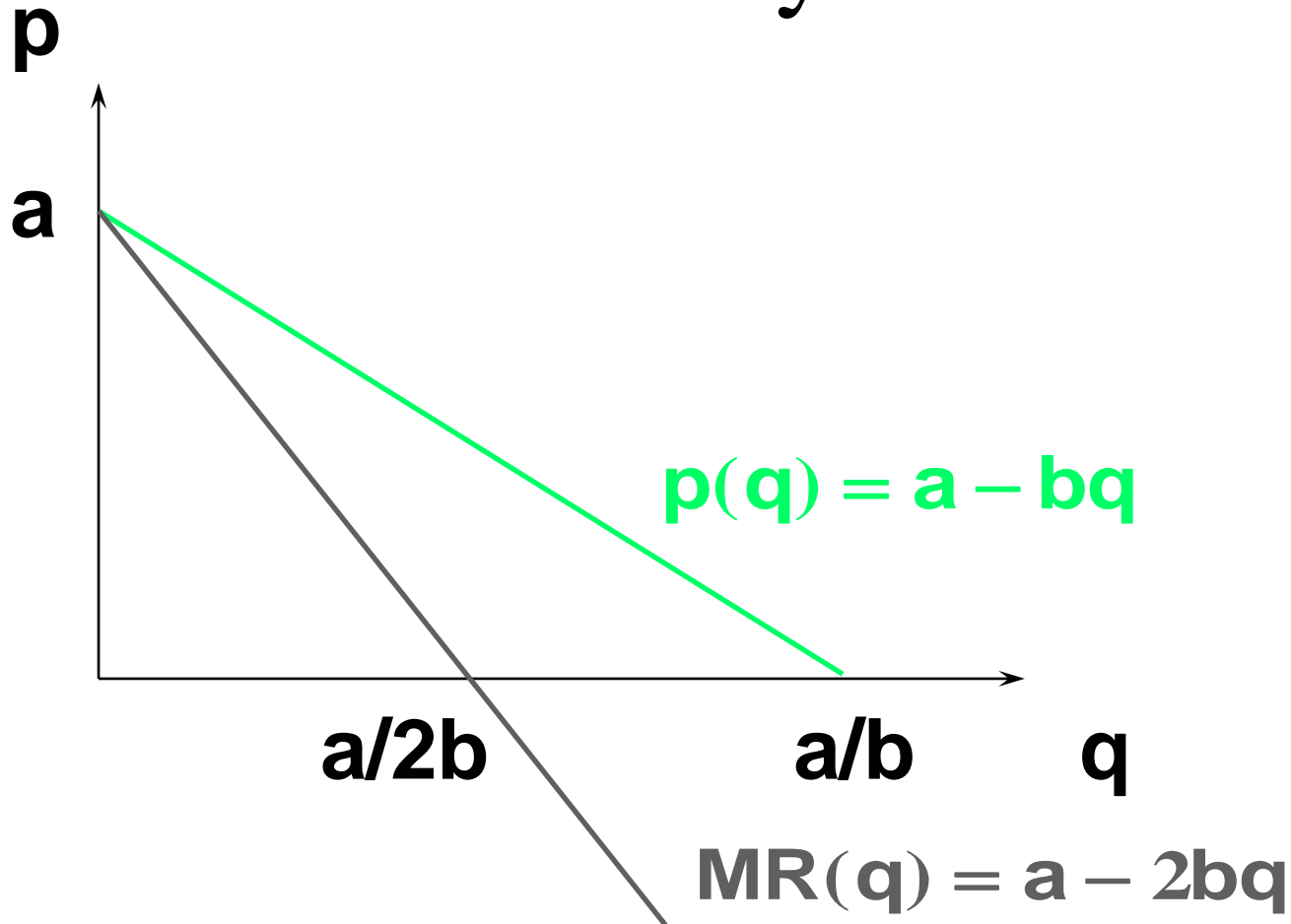

Marginal Revenue and Own-Price Elasticity of Demand

