Multi User MIMO Communication: Basic Aspects, Benefits and Challenges

Ben Zid Maha and Raoof Kosai

Additional information is available at the end of the chapter

<http://dx.doi.org/10.5772/57133>

1. Introduction

The explosive growth of Multiple Input Multiple Output (MIMO) systems has permitted for high data rate and a wide variety of applications. Some of the technologies which rely on these systems are IEEE 802.11, Third Generation (3G) and Long Term Evolution (LTE) ones. Recent advances in wireless communication systems have contributed to the design of multi-user scenarios with MIMO communication. These communication systems are referred as multi-user MIMOs. Such systems are intended for the development of new generations of wireless mobile radio systems for future cellular radio standards. This chapter provides an insight into multi-user MIMO systems. We firstly present some of the main aspects of the MIMO communication. We introduce the basic concepts of MIMO communication as well as MIMO channel modeling. Thereafter, we evaluate the MIMO system performances. Then, we concentrate our analysis on the multi-user MIMO systems and we provide the reader a conceptual understanding with the multi-user MIMO technology. To do so, we present the communication system model for such emerging technology and we give some examples which describe the recent advances for multi-user MIMO systems. Finally, we introduce linear precoding techniques which could be exploited in multi-user MIMO systems in order to suppress inter-user interference.

2. MIMO communication

2.1. An historical overview

The main historical events which make the MIMO systems [2][3] are summarized as follows:

- In 1984, Jack Winters at Bell Laboratories wrote a patent on wireless communications using multiple antennas. Jack Winters in [4] presented a study of the fundamental limits on the data rate of multiple antenna systems in a Rayleigh fading environment.

- In 1993, Arogyaswami Paulraj and Thomas Kailath proposed the concept of spatial multiplexing using MIMO.
- Several articles which focused on MIMO concept were published in the period from 1986 to 1995 [5]. This was followed by the work of Greg Raleigh and Gerard Joseph Foschini in 1996 which invented new approaches involving space time coding techniques. These approaches were proved to increase the spectral efficiency of MIMO systems.
- In 1999, Thomas L. Marzetta and Bertrand M. Hochwald published an article [6] which provides a rigorous study on the MIMO Rayleigh fading link taking into consideration information theory aspects.
- The first commercial MIMO system was developed in 2001 by Iospan Wireless Inc.
- Since 2006, several companies such as Broadcom and Intel have introduced a novel communication technique based on the MIMO technology for improving the performance of wireless Local Area Network (LAN) systems. The new standard of wireless LAN systems is named IEEE 802.11n.

Nowadays, MIMO systems are implemented in many advanced technologies such as various standard proposals for the Fourth Generation (4G) of wireless communication systems and LTE. MIMO technology was shown to boost the communication system capacity and to enhance the reliability of the communication link since it uses several diversity schemes beyond the spatial diversity.

2.2. Fundamentals of MIMO system

MIMO system model is depicted in Figure 1. We present a communication system with N_T transmit antennas and N_R receive antennas.

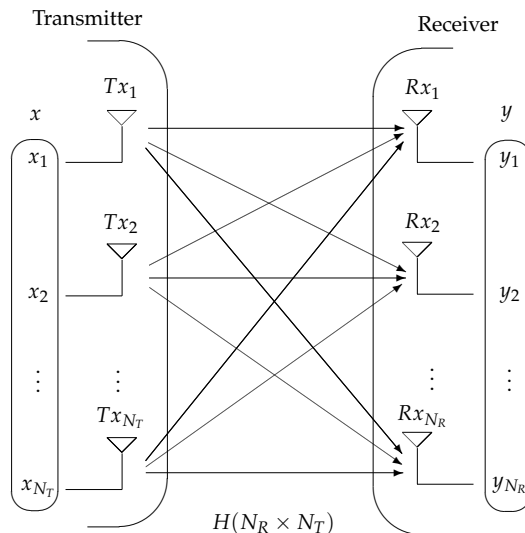

Figure 1. MIMO system model

Antennas Tx_1, \dots, Tx_{N_T} respectively send signals x_1, \dots, x_{N_T} to receive antennas Rx_1, \dots, Rx_{N_R} . Each receive antenna combines the incoming signals which coherently add up. The received signals at antennas Rx_1, \dots, Rx_{N_R} are respectively denoted by y_1, \dots, y_{N_R} . We express the received signal at antenna Tx_q ; $q = 1, \dots, N_R$ as:

$$y_q = \sum_{p=1}^{N_T} h_{qp} \cdot x_p + b_q \quad ; \quad q = 1, \dots, N_R \quad (1)$$

The flat fading MIMO channel model is described by the input-output relationship as:

$$y = H \cdot x + b \quad (2)$$

- H is the $(N_R \times N_T)$ complex channel matrix given by:

$$H = \begin{pmatrix} h_{11} & h_{12} & \dots & h_{1N_T} \\ h_{21} & h_{22} & \dots & h_{2N_T} \\ \vdots & \vdots & \ddots & \vdots \\ h_{N_R1} & h_{N_R2} & \dots & h_{N_RN_T} \end{pmatrix}$$

h_{qp} ; $p = 1, \dots, N_T$; $q = 1, \dots, N_R$ is the complex channel gain which links transmit antenna Tx_p to receive antenna Rx_q .

- $x = [x_1, \dots, x_{N_T}]^T$ is the $(N_T \times 1)$ complex transmitted signal vector.
- $y = [y_1, \dots, y_{N_R}]^T$ is the $(N_R \times 1)$ complex received signal vector.
- $b = [b_1, \dots, b_{N_R}]^T$ is the $(N_R \times 1)$ complex additive noise signal vector.

The continuous time delay MIMO channel model of the $(N_R \times N_T)$ MIMO channel H associated with time delay τ and noise signal $b(t)$ is expressed as:

$$y(t) = \int_{\tau} H(t, \tau) x(t - \tau) d\tau + b(t) \quad (3)$$

- $y(t)$ is the spatio-temporel output signal.
- $x(t)$ is the spatio-temporel input signal.
- $b(t)$ is the spatio-temporel noise signal.

$(\cdot)^T$ denotes the transpose operator.

2.3. MIMO channel modeling

Several MIMO channel models [7] have been proposed in literature. These models mainly fall into two categories as depicted in Figure 2.

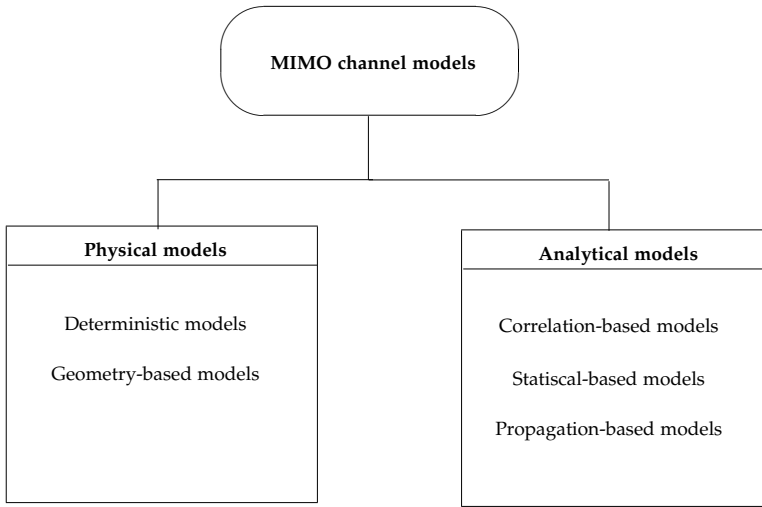

Figure 2. MIMO channel propagation models

2.3.1. Physical models

MIMO channel impulse response is evaluated according to the radio wave which propagates from the transmitter to the receiver. The MIMO channel model is determined based on the experimental measurements made for extracting channel propagation parameters including antenna configuration at both the transmitter and the receiver, antenna polarization, scatterers, ... Physical models include both deterministic models and Geometry-based stochastic channel models (GSCMs).

- Deterministic models define a channel model according to the prediction of the propagation signal.
- Geometry-based Stochastic Channel Models (GSCMs) have an immediate relation with the physical characteristics of the propagation channel. These models suppose that clusters of scatterers are distributed around the transmitter and the receiver. The scatterers locations are defined according to a random fashion that follows a particular probability distribution. Scatterers result in discrete channel paths and can involve statistical characterizations of several propagation parameters such as delay spread, angular spread, spatial correlation and cross polarization discrimination. We distinguish two possible schemes which are the Double Bounce Geometry-based Stochastic Channel Models (DB-GSCMs) and the Single Bounce Geometry-based Stochastic Channel Models (SB-GSCMs). That is when a single bounce of scatterers is placed around the transmit antennas or receive antennas.

2.3.2. Analytical models

The second class of MIMO channel models includes analytical models which are based on the statistical properties obtained through measurement (Distribution of Direction of Departure (DOD), distribution of Direction of Arrival (DOA), ...). Analytical channel models can be

classified into correlation-based models (such as i.i.d model, Kronecker model, Keyhole model,..), statistical -based models (such as Saleh-Valenzuela model and Zwick model) and propagation-based models (such as Müller model and Finite scatterer model). We provide in [8] a detailed description of MIMO systems with geometric wide MIMO channel models where advanced polarization techniques [9][10] are exploited.

2.4. MIMO system performances

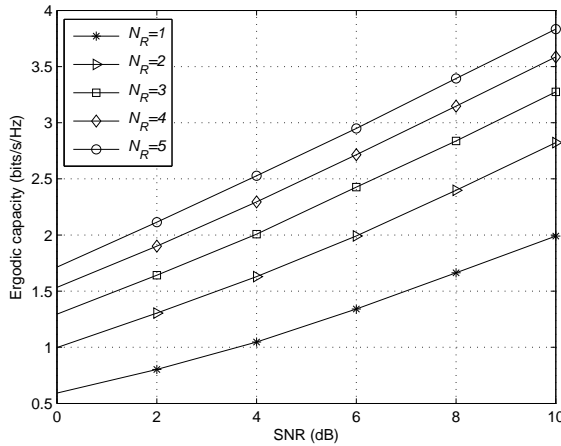

Figure 3. Ergodic capacity for MIMO systems

MIMO technology has been shown to improve the capacity of the communication link without the need to increase the transmission power. MIMO system capacity is mainly evaluated according to the following scenarios:

1. When no Channel State Information (CSI) is available at the transmitter, the power is equally split between the N_T transmit antennas, the instantaneous channel capacity is then given by:

$$C(H) = \log_2 \left[\det \left(I_{N_R} + \frac{\gamma}{N_T} \cdot HH^* \right) \right] \text{ bits/s/Hz} \tag{4}$$

γ denotes the Signal to Noise Ratio (SNR).
 $(\cdot)^*$ stands for the conjugate transpose operator.

2. When CSI is available at the receiver, Singular Value Decomposition (SVD) is used to derive the MIMO channel capacity which is given by:

$$C_{SVD}(H) = R \cdot \log_2 \left[\det \left(1 + \frac{\gamma}{N_T} HH^* \right) \right] \text{ bits/s/Hz} \tag{5}$$

$R = \min(N_R, N_T)$ is the rank of the channel matrix H

3. When CSI is available at both the transmitter and the receiver, the channel capacity is computed by performing the water-filling algorithm. The instantaneous channel capacity is then:

$$C_{WF}(H) = \sum_{p=1}^R \log_2 \left[\left(\frac{\lambda_{H,p} \cdot \mu}{\sigma_b^2} \right)^+ \right] \text{ bits/s/Hz} \quad (6)$$

- $a^+ = \max(a, 0)$
- $\lambda_{H,p}$ is the p -th singular value of the channel matrix H
- μ is a constant scalar which satisfies the total power constraint
- σ_b^2 is the noise signal power

We consider the case where CSI is available at the receiver, the simulated ergodic MIMO capacity is depicted in Figure 3. For a MIMO system with two transmit antennas, numerical results show that ergodic capacity linearly increases with the number of antennas. Plotted curves are presented for different levels of the SNR. The use of additional antennas improves the performances of the communication system. Moreover, MIMO system takes advantage of multipath propagation. The performances of MIMO system are observed in the following in terms of the Bit Error Rate (BER). We consider a MIMO system with various receive antennas, the BER is evaluated for communication systems with Rayleigh fading MIMO channel and additive gaussian noise. At the receive side, the Maximum Ratio Combining (MRC) technique is performed. According to Figure 4, it is obvious that MIMO technology allows for a significant improvement of the BER.

Once the MIMO technology is presented, we introduce in the following multi-user MIMO systems.

3. Multi-user MIMO system

The growth in MIMO technology has led to the emergence of new communication systems. We are particularly interested in this chapter in multi-user MIMO (MU-MIMO) ones [11]. MU-MIMO [12] system is often considered in literature as an extension of Space-Division Multiple Access (SDMA). This technology supports multiple connections on a single conventional channel where different users are identified by spatial signatures. SDMA uses spatial multiplexing and enables for higher data rate. This could be achieved by using multiple paths as different channels for carrying data. Another benefit of using the SDMA technique in cellular networks is to mitigate the effect of interference coming from adjacent cells. Traditional communication MIMO systems are usually referred as single-user MIMO systems (SU-MIMOs) or also point-to-point MIMO. Case of MIMO systems, the access point communicates with only one mobile terminal (the user). Both the access point and the mobile terminal are equipped with multiple antennas. In contrast to the single-user case, the access point is able to communicate with several mobile terminals. SU-MIMO and MU-MIMO systems are two possible configurations for multi-user communication systems. We also find other configurations in literature such as MU-MIMO with cooperation where cooperation is

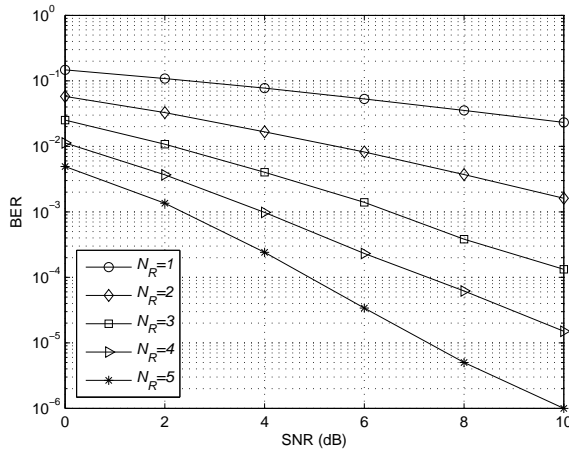

Figure 4. Improvement of the BER for MIMO ($N_R \times 2$) as a function of receive antennas number

established between base stations [2]. Basic configurations of downlink multi-user MIMO systems are depicted in Figure 5. Figure 5(a) represents the SU-MIMO system where a Base Station (BS) equipped with antennas Tx_1, \dots, Tx_N communicates with user U which is equipped with M antennas Rx_1, \dots, Rx_M . In Figure 5(b), the presented MU-MIMO system consists of two base stations BS_1 and BS_2 each one is equipped with N antennas. Generalized MU-MIMO systems may consist of more base stations where the number of antennas could be different. At the receive side, K users U_1, \dots, U_K with respectively M_1, \dots, M_K antennas communicate with the transmit base stations. The same communication model is performed for the MU-MIMO with cooperation (Figure 5(c)) where cooperation is established between BS_1 and BS_2 .

Once multi-user communication systems are introduced, we explain in the following section the difference between SU-MIMO and MU-MIMO configurations.

4. MU-MIMO vs SU-MIMO

Table 1 summarizes the main features of both SU-MIMO and MU-MIMO systems [13]. In contrast to MU-MIMO systems where one base station could communicate with multiple users, base station only communicate with a single user in the case of SU-MIMO systems. In addition, MU-MIMO systems are intended to employ multiple receivers so that to improve the rate of communication while keeping the same level of reliability. These systems are able to achieve the overall multiplexing gain obtained as the minimum value between the number of antennas at base stations and the number of antennas at users. The fact that multiple users could simultaneously communicate over the same spectrum improves the system performance. Nevertheless, MU-MIMO networks are exposed to strong co-channel interference which is not the case for SU-MIMO ones. In order to solve the problem of interference in MU-MIMO systems, several approaches have been proposed for interference management [14][15]. Some of these approaches are based on beamforming technique [31]. Moreover, in contrast to SU-MIMO systems, MU-MIMO systems require perfect CSI in

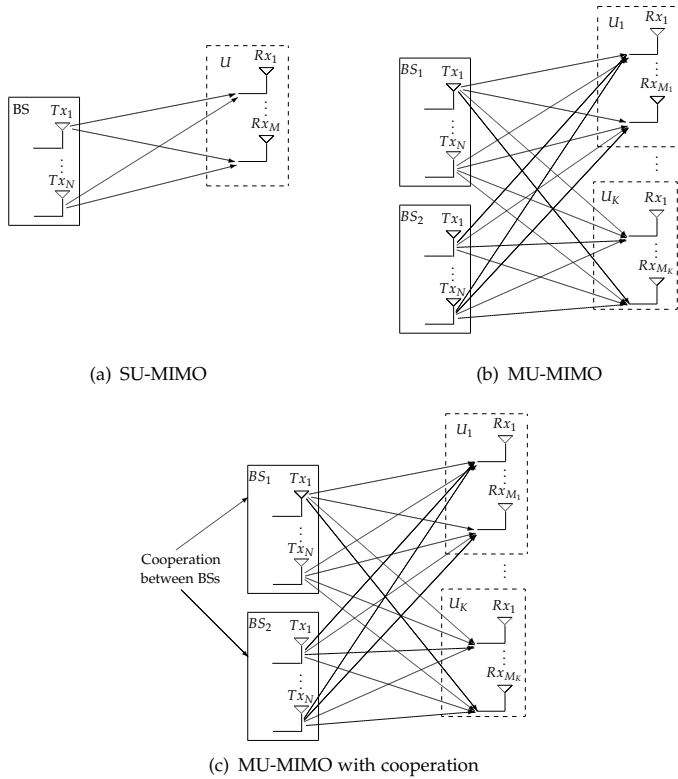

Figure 5. MU-MIMO configurations

order to achieve high throughput and to improve the multiplexing gain [16]. Finally, the performances of MU-MIMO and SU-MIMO systems in terms of throughput depend on the SNR level. In fact, at low SNRs, SU-MIMO performs better. However, at high SNRs level, MU-MIMO provides better performances.

Feature	MU-MIMO	SU-MIMO
Main aspect	BS communicates with multiple users	BS communicates with a single user
Purpose	MIMO capacity gain	Data rate increasing for single user
Advantage	Multiplexing gain	No interference
CSI	Perfect CSI is required	No CSI
Throughput	Higher throughput at high SNR	Higher throughput at low SNR

Table 1. Comparison between SU-MIMO and MU-MIMO systems

5. Communication schemes for MU-MIMO systems

Communication schemes for MU-MIMO systems include both uplink MU-MIMO (UL-MU-MIMO) and downlink MU-MIMO (DL-MU-MIMO). Case of uplink communication,

users transmit signals to the base station. However, in the case of downlink communication, base station transmits signals to users. A representation of these systems is depicted in Figure 6. We assume that the base station is equipped with N antennas. Case of DL-MU-MIMO, the base station attempts to transmit signals to K users U_1, \dots, U_K which are respectively equipped with antennas of numbers M_1, \dots, M_K .

For notations, if antenna k acts like a receiving antenna, it is denoted by Rx_k . Otherwise, it is denoted by Tx_k .

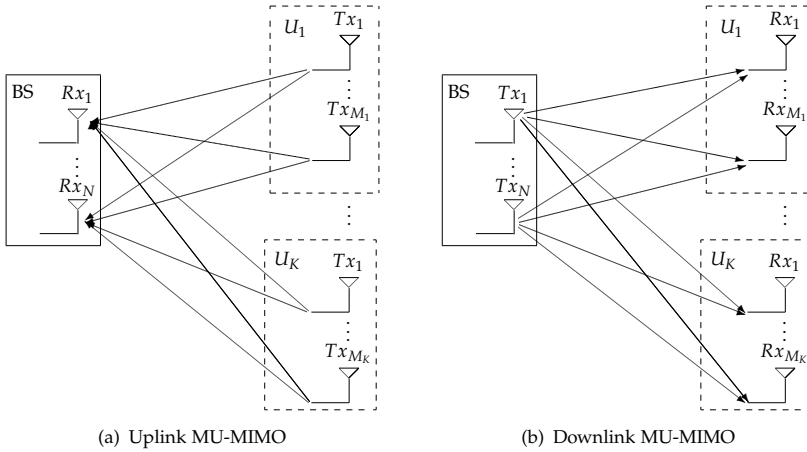

Figure 6. MU-MIMO communication models: UL-MU-MIMO and DL-MU-MIMO

5.1. UL-MU-MIMO

Let $X_k(M_k \times 1)$, the transmit signal vector of user U_k ; $k = 1, \dots, K$. We assume that data streams associated to user U_k ; $k = 1, \dots, K$ are zero mean white random vectors where :

$$E\{X_k X_k^*\} = I_{M_k}; \quad k = 1, \dots, K \tag{7}$$

E denotes the expected value operator.

The complex channel matrix relating user U_k ; $k = 1, \dots, K$ to the base station, H_k is of dimension $(N \times M_k)$. In presence of additive noise signal $b(N \times 1)$, the received signal vector at the base station, $y(N \times 1)$ is expressed in the slow fading model by:

$$y = \sum_{k=1}^K H_k \cdot X_k + b \tag{8}$$

The noise signal vector is a zero mean white Gaussian variable with variance σ_b^2 . The uplink scenario should satisfy two constraints:

- It should be as many receive antennas at the base station as the total number of users antennas.

- Each user should have as many transmit antennas as the number of data streams.

In Figure 7, the block diagram for the UL-MU-MIMO includes a joint linear precoder and decoder. Linear precoders associated to users U_1, \dots, U_K will be respectively denoted by

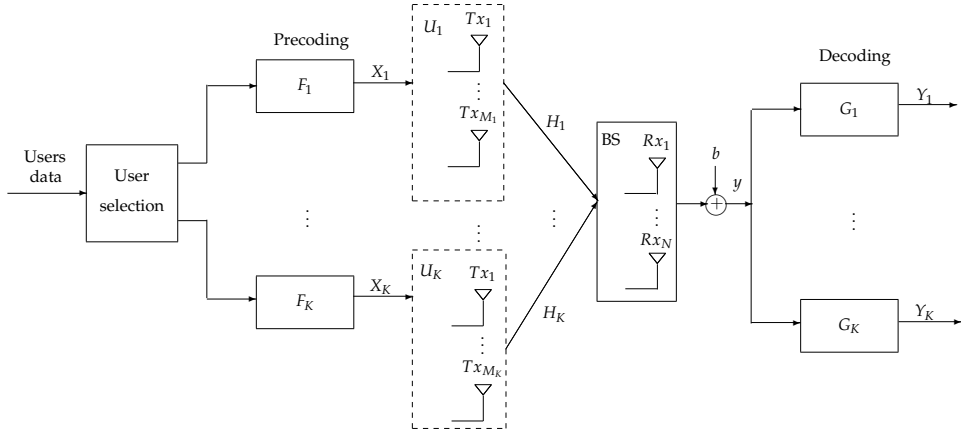

Figure 7. Block diagram for the UL-MU-MIMO with coding techniques: N antenna BS and K multiple antenna users

U_1, \dots, U_K . The received signal vector at the BS is then expressed as :

$$y = \sum_{k=1}^K H_k \cdot F_k \cdot X_k + b \tag{9}$$

An estimate of the transmitted signal vectors denoted by Y_k ; $k = 1, \dots, K$ are obtained by using the linear decoders G_1, \dots, G_K . The decoding process is such that :

$$Y_k = G_k \cdot y$$

5.2. DL-MU-MIMO

DL-MU-MIMO communication model assumes that K users are simultaneously receiving signals from the base station. The transmitted signal vector $x(N \times 1)$ is expressed as the sum of signals intended to users U_1, \dots, U_K :

$$x = \sum_{k=1}^K X_k \tag{10}$$

The channel matrix between user U_k ; $k = 1, \dots, K$ and the base station is denoted by $H_k(M_k \times N)$. At each user, received signal vector of dimension $(M_k \times 1)$; $k = 1, \dots, K$ is given by:

$$Y_k = H_k \cdot x + B_k \quad ; \quad k = 1, \dots, K \tag{11}$$

B_k ; $k = 1, \dots, K$ is an additive noise signal vector of size $(M_k \times 1)$. Equation (11) could be also written:

$$Y_k = H_k \cdot x + B_k \quad (12)$$

$$= H_k \cdot X_k + \sum_{j \neq k}^K (H_k \cdot X_j) + B_k \quad ; \quad k = 1, \dots, K \quad (13)$$

The second term of the sum in equation (13) represents the interference signal coming from multiple users. Processing techniques such as beamforming should be introduced in the block diagram of the MU-MIMO system for mitigating the effect of users interference and improving the performances of the communication system.

6. Fields of application

MU-MIMO technology finds its applications in many areas and is nowadays exploited in many evolving technologies which are described in the following.

3GPP LTE: 3rd Generation Partnership Project (3GPP) Long Term Evolution (LTE) is one of the next generation cellular networks which exploit the MU-MIMO technology. Thanks to this technology, available radio spectrum 3GPP LTE networks could achieve higher spectral efficiencies than existing 3G networks [18][19].

Release 8 of LTE: The first release of LTE (Release 8) was commercially deployed in 2009. Release 8 has introduced SU-MIMO scheme in the communication system model. This release only uses one transmission mode (Transmission mode 5) which has been defined for MU-MIMO systems. Transmission mode 5 supports rank 1 transmission for two User Equipments (UEs). In order to achieve the performances of MU-MIMO systems, feedback parameters such as the channel Rank Indicator (RI) and the Channel Quality Indicator (CQI)/Precoding Matrix Indicator (PMI) feedback [17] are required.

Release 9 of LTE: The second release of LTE (Release 9) provides enhancements to Release 8. The LTE Release 9 supports transmission mode 8 and includes both SU-MIMO and MU-MIMO schemes.

LTE advanced: Other progress in LTE MIMO systems have been obtained through LTE advanced. The performed mode is the transmission mode 9. This mode allows for a possible switch between SU-MIMO and MU-MIMO.

Multiple-cell networks: MU-MIMO systems have received wide spread success in wireless networks. Examples of applications include the multiple-cell networks [21] with multiple access channels where possible coordination among base stations is established. Figure 8 shows a MU-MIMO coordinated network in a cellular network. Three classes of cells are presented. These cells are referred as :

- Coordinated cells
- Central cell
- Interfering cells

The coordination between cells is performed by the Central Station (CS). The aim of this coordination is to mitigate the effect of inter-cells interference. Coding techniques should be employed in order to mitigate the effect of interfering cells.

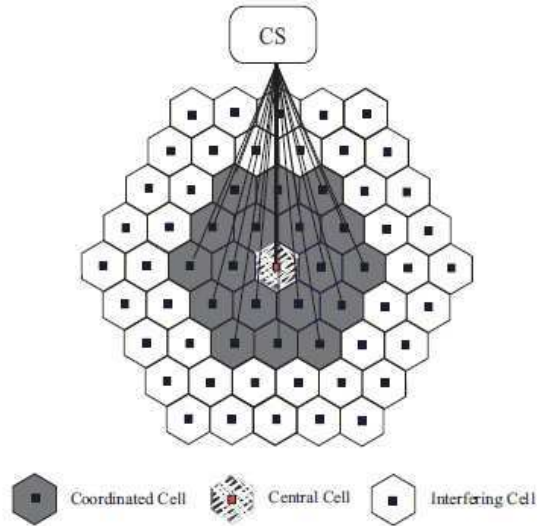

Figure 8. MU-MIMO coordinated network in cellular network [20]

Digital Subscriber Line (DSL): MU-MIMO systems are not only performed by multi-cell systems but also find their applications in other systems such as the downlink of a Digital Subscriber Line (DSL)[22][13].

The performance of MU-MIMO could be improved via the use of Orthogonal Frequency Division Multiplexing (OFDM) or Orthogonal Frequency Division Multiplexing Access (OFDMA) for multiple access scenarios in frequency selective channels. MU-MIMO systems could also improve multi-user diversity by performing High Data Rate (HDR) or Code Division Multiple Access (CDMA) techniques.

7. Capacity region of multi-user MIMO system

There is no closed form for the channel capacity of multi-user MIMO systems. For this purpose, the performances of such systems will be analyzed in terms of the capacity region. This metric [23] could be defined in the usual Shannon sense as the highest rates that can be achieved with arbitrarily small error probability. Firstly, the capacity [24] needs to be evaluated for each user. Then, the capacity region is determined as the entire region for which maximum achievable rates are reached. The evaluation of the capacity region is strongly related to some constraints and should be determined according to the performed communication scenario.

We address the following scenarios :

1. UL-MU-MIMO with single antenna users
2. UL-MU-MIMO with multiple antenna users
3. DL-MU-MIMO with multiple antenna users and single antenna BS

7.1. Capacity region of UL-MU-MIMO with single antenna users

We consider the UL-MU-MIMO with N multiple antenna BS and K single antenna users. The performed communication scheme is depicted in Figure 9. The equivalent MIMO channel for the presented communication model is given by:

$$H = [H_1, \dots, H_K] \tag{14}$$

$H_k(N \times 1)$; $k = 1, \dots, K$ represents the Single Input Multiple Output (SIMO) channel between user U_k ; $k = 1, \dots, K$ and the BS. Case of two users (i.e. $K=2$), the capacity region is defined as the set of rates (R_1, R_2) associated to users U_1 and U_2 .

We consider the notations:

- P_1 : average power constraint on user U_1
- P_2 : average power constraint on user U_2
- N_0 : noise signal power

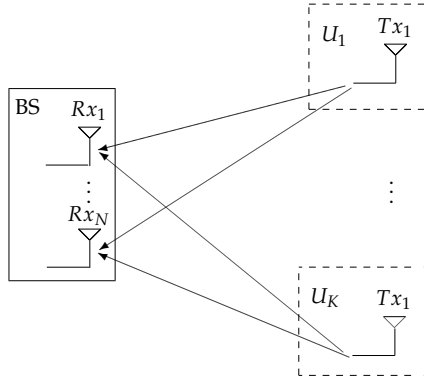

Figure 9. UL-MU-MIMO with N multiple antenna BS and K single antenna users

The capacity region [25] is evaluated by determining the individual rate constraint for each user. Assuming that user U_1 has the entire channel, an upper bound of the maximum achievable rate is given by :

$$R_1 \leq \log_2 \left(1 + \frac{\|H_1\|^2 \cdot P_1}{N_0} \right) \tag{15}$$

$\|\cdot\|$ indicates the Frobenius norm.

Similarly, an upper bound for the maximum achievable rate for user U_2 is:

$$R_2 \leq \log_2 \left(1 + \frac{\|H_2\|^2 \cdot P_2}{N_0} \right) \tag{16}$$

Finally, the sum rate constraint which is obtained when both users are acting as two transmit antennas of a single user has an upper bound expressed as :

$$R_1 + R_2 \leq \log_2 \left[\det \left(I_N + \frac{H \cdot \text{diag}(P_1, P_2) \cdot H^*}{N_0} \right) \right] \quad (17)$$

The capacity region for the UL-MU-MIMO is presented in Figure 10 where two users with single antennas are considered.

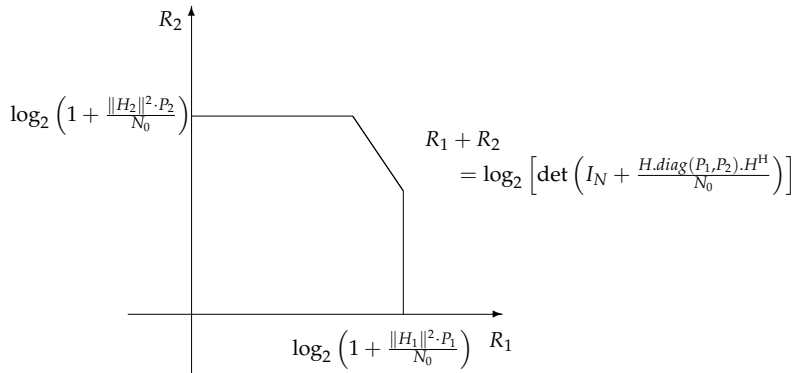

Figure 10. Capacity region of UL-MU-MIMO for two single antenna users

Case of K users, the capacity region is determined as a function of several constraints and $K!$ corner points are determined for evaluating the boundary of the capacity region. For rates R_1, \dots, R_K respectively associated to users U_1, \dots, U_K , the sum rate is determined for an optimal receiver [25] as:

$$\sum_{k \in S} R_k \leq \log_2 \left[\det \left(I_N + \frac{1}{N_0} \sum_{k \in S} P_k \cdot H_k \cdot H_k^* \right) \right]; \quad S \subset \{1, \dots, K\} \quad (18)$$

7.2. Capacity region of UL-MU-MIMO with multiple antenna users

The capacity region could be obtained for the generalized case where the base station has N antennas and user U_k ; $k = 1, \dots, K$ is equipped with multiple antennas of number $M_k > 1$. An upper bound of the maximum achievable rate for user U_k is given by :

$$R_k \leq \log_2 \left[\det \left(I_N + \frac{H_k \cdot D_k \cdot H_k^*}{N_0} \right) \right]; \quad k = 1, \dots, K \quad (19)$$

- $H_k(N \times M_k)$ links the N antenna base station to the M_k antenna user; $k = 1, \dots, K$.
- $D_k(M_k \times M_k)$ is a diagonal matrix formed by the power allocated at transmit antennas at user U_k .

The sum rate constraint of UL-MU-MIMO with multiple antennas users is expressed as :

$$R_1 + \dots + R_K \leq \log_2 \left[\det \left(I_N + \frac{\sum_{k=1}^K H_k \cdot D_k \cdot H_k^*}{N_0} \right) \right] \quad (20)$$

7.3. DL-MU-MIMO with multiple antenna users and single antenna BS

In the case of downlink scenario, the upper bounds of the users rates are analogously determined as the uplink scenario. Nevertheless, the effect of interference could not be neglected. In fact, for the scenario with two multiple antenna users U_1 and U_2 and one antenna base station, the upper bounds of the rates achievable by users U_1 and U_2 become:

$$R_1 \leq \log_2 \left(1 + \frac{\|H_1\|^2 \cdot P_1}{N_0 + \|H_1\|^2 \cdot P_2} \right) \quad (21)$$

and

$$R_2 \leq \log_2 \left(1 + \frac{\|H_2\|^2 \cdot P_2}{N_0} \right) \quad (22)$$

Here, the signal of user U_2 is considered as interference for user U_1 .

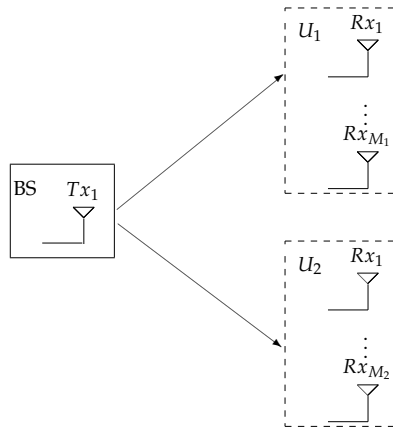

Figure 11. DL-MU-MIMO with multiple antenna users and single antenna BS

8. Precoding techniques

The DL-MU-MIMO system uses precoding techniques which are usually linear.

8.1. Zero Forcing and Block Diagonalization methods

Popular low-complexity techniques include both Zero Forcing (ZF) and Block Diagonalization (BD)[27][28] methods. Algorithms for the ZF as well as BD methods are presented in [29]. The aim of these solutions is to improve the sum rate capacity of the communication system under a given power constraint. These performances could be achieved by canceling inter-user interference. Zero Forcing Dirty Paper Coding (DPC) [30] represents a famous technique for data precoding where the channel is subject to interference which is assumed to be known at the transmitter. The precoding matrix is equal to the conjugate transpose of the upper triangular matrix obtained via the QR decomposition of the channel matrix.

8.1.1. MU-MIMO with Block Diagonalization precoding

We consider a communication system model with a broadcast MIMO channel where the transmitter is a base station equipped with N antennas and the receiver consists of K users U_k ; $k = 1 \dots K$ (See figure 6(b)). The received signal at user U_k ; $k = 1 \dots K$ with dimension $(M_k \times 1)$ is expressed as :

$$Y_k = H_k \cdot V_{BD}^{(k)} \cdot X_k + B_k \quad ; \quad k = 1, \dots, K \quad (23)$$

- $H_k (M_k \times N)$ is the channel matrix between user U_k and the base station
- $V_{BD}^{(k)} (N \times M_k)$ is the BD precoding matrix for user U_k
- X_k is the transmit signal for user U_k
- $B_k (M_k \times 1)$ is the additive noise signal vector

We assume in the following that users U_1, \dots, U_K have the same number of antennas which will be denoted by M . Block Diagonalization strategy defines a set of precoding matrices $V_{BD}^{(k)} (N \times M)$ associated to users U_1, \dots, U_K . These matrices form an orthonormal basis such that:

$$[V_{BD}^{(k)}]^* \cdot V_{BD}^{(k)} = I_M \quad ; \quad k = 1 \dots K \quad (24)$$

and the Block Diagonalization algorithm achieves :

$$H_k \cdot V_{BD}^{(j)} = 0 \quad ; \quad \forall j \neq K \quad (25)$$

The aim of these conditions is to eliminate multi-user interference so that to maximize the achievable throughput.

The performance of downlink communication scenarios with precoding techniques depends on the SNR level. In fact, it has been shown in [27] that SU-MIMO achieves better performances than MU-MIMO at low SNRs. However, the BD MU-MIMO achieves better performances at high SNRs. As such, switching between SU-MIMO and MU-MIMO is optimal for obtaining better total rates over users.

8.1.2. MU-MIMO with Zero Forcing precoding

Case of Zero Forcing strategy, each transmitted symbol to the l – th antenna (among M antennas of user U_k) is preceded by a vector which is orthogonal to the columns of H_j , $j \neq k$ but not orthogonal to the l – th column of H_k [26].

8.2. Beamforming for linear precoding

Beamforming paradigms represent another class of linear precoding for MU-MIMO systems. For the communication model with beamforming (Figure 12), we consider a MU-MIMO system with K multiple antenna users U_1, \dots, U_K at the receive side which are respectively equipped with M_1, \dots, M_K antennas. At the transmit side, a multiple antenna base station with N antennas transmits data signals x_1, \dots, x_K to users U_1, \dots, U_K .

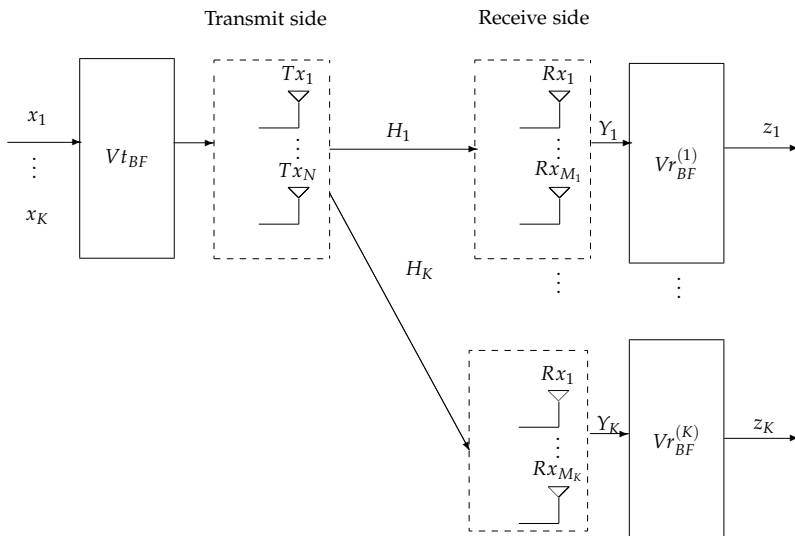

Figure 12. MU-MIMO with beamforming

The received signal vector at user U_k ; $k = 1, \dots, K$ is expressed as :

$$Y_k = H_k \cdot V_{BF}^{(k)} \cdot x_k + \sum_{j=1, k \neq j}^K H_k \cdot V_{BF}^{(j)} \cdot x_j + B_k \quad ; \quad k = 1, \dots, K \quad (26)$$

where:

- $H_k (M_k \times N)$ is the complex channel matrix between receiver U_k and the transmit base station.
- $B_k (M_k \times 1)$ is an additive noise signal vector.

- $Vt_{BF}^{(k)} (N \times 1)$ is the transmit beamforming vector of index k . The transmit beamforming matrix is :

$$Vt_{BF} = [Vt_{BF}^{(1)}, \dots, Vt_{BF}^{(k)}] \quad (27)$$

At the receive side, beamforming vectors are denoted by $Vr_{BF}^{(k)} (M_k \times 1)$.

$$Vr_{BF}^{(k)} = [vr_{BF}^{(1)}, \dots, vr_{BF}^{(M_k)}]^T \quad (28)$$

The resulting signal at user U_k is:

$$z_k = Y_k^* \cdot Vr_{BF}^{(k)} \quad ; \quad k = 1, \dots, K \quad (29)$$

The conjoint receive-transmit beamforming weights are obtained by maximizing the sum rate of the MU-MIMO system expressed as:

$$R_{sum} = \sum_{k=1}^K \log_2(1 + SINR^{(k)}) \quad (30)$$

$SINR^{(k)}$; $k = 1, \dots, K$ is the Single Interference Noise Ratio (SINR) [31] associated to user U_k . The SINR is determined as the ratio of the received strength for the desired signal to the strength of undesired signal obtained as the sum of noise and interference signal.

For unit signal noise variance, the SINR for user U_k is given by :

$$SINR^{(k)} = \frac{\| Vr_{BF}^{(k)} \cdot H_k^* \cdot Vt_{BF}^{(k)} \|^2}{\left(\sum_{k=1}^K \| Vr_{BF}^{(k)} \cdot H_k^* \cdot Vt_{BF}^{(k)} \|^2 \right) + 1} \quad (31)$$

Beamforming weights at the receiver are determined so that to suppress inter-user interference such as [32]:

$$Vr_{BF}^{(k)} = \frac{[C^{(k)}]^{-1} \cdot H_k \cdot Vt_{BF}^{(k)}}{\|[C^{(k)}]^{-1} \cdot H_k \cdot Vt_{BF}^{(k)}\|_2} \quad (32)$$

$C^{(k)}$ is the covariance matrix of H_k .
 $\| \cdot \|_2$ stands for the 2-norm operator.

9. Conclusion

This chapter presents a basic introduction to the fundamentals of multi-user MIMO communication. MU-MIMO is considered as an enhanced form of MIMO technology. Such technology has been a topic of extensive research since the last three decades. The attractive features of MIMO systems have shown that the use of multiple antennas at both the ends of

the communication link significantly improves the spectral efficiency of the communication system as well as the reliability of the communication link.

In multiuser channels and cellular systems, MIMO is offered for MU-MIMO communication to allow for spatial sharing of the channel by several users.

Nowadays, it has been a great deal with MU-MIMO systems. Several approaches are adopted and different scenarios may be considered. Throughout this chapter, we have presented possible configurations associated with MU-MIMO with particular emphasis on the fundamental differences between SU-MIMO and MU-MIMO.

Some scenarios have been considered for performance evaluation of MU-MIMO communication in terms of the capacity region metric.

MU-MIMO scenarios follow into UL-MU-MIMO for Multiple Access Channel (MAC) and the DL-MU-MIMO for Broadcast Channel (BC). The DL-MU-MIMO is the more challenging scenario since optimum strategies for interference cancelation are required.

Throughout this chapter, we have presented precoding techniques used within MU-MIMO systems for efficient transmission and interference cancelation. Among the existing techniques, we have introduced ZF and BD methods. Of particular interest, we have described the linear beamforming algorithms.

The design of multi-user MIMO systems is attractive for the research field as well for the industrial one and the field of application is extensively growing.

Author details

Ben Zid Maha^{1,*} and Raouf Kosai^{1,2}

* Address all correspondence to: maha.ben-zid@gipsa-lab.grenoble-inp.fr

1 École Nationale Supérieure d'Ingénieurs du Mans (ENSIM), Le Mans, France

2 Laboratoire d'Acoustique de l'Université du Maine, (LAUM), UMR CNRS 6613, Le Mans, France

References

- [1] Ben Zid, M., Raouf, K. and Bouallègue, A. (2012). MIMO spectral efficiency over energy consumption requirements: Application to WSNs, *Int'l J. of Communications, Network and System Sciences* Vol. 5(No. 2): 121–129.
- [2] Ben Zid, M., Raouf, K. and Bouallègue, A. (2012). MIMO Systems and Cooperative Networks Performances, in: *Advanced Cognitive Radio Network*, Scientific Research Publishing, ISBN: 193–506–874–1.
- [3] Raouf, K. and Zhou, H. (2009). *Advanced MIMO systems*, Scientific Research Publishing, ISBN:978–1–935068–02–0.
- [4] Winters, J.H. (1987). On the capacity of radio communication systems with diversity in a Rayleigh fading environment, *IEEE Journal on Selected Areas in Communications* Vol. 5(No. 5): 871–878.

- [5] Telatar, I. E.(1995). Capacity of multi-antenna Gaussian channels, *European Transactions on Telecommunications* Vol. 10(No. 6): 585–595.
- [6] Marzetta, T. L. and Hochwald, B. M. (1999). Capacity of a mobile multiple-antenna communication link in Rayleigh flat fading, *IEEE Transactions on Information Theory* Vol. 45(No. 1): 139–157.
- [7] Almers, P., Bonek, E., Burr, A., Czink, N. and Debbah, M.(2007). Survey of channel and radio propagation models for wireless MIMO systems, *EURASIP Journal on Wireless Communications and Networking* Vol. 2007(No. 1): 1–19.
- [8] Ben Zid, M.(2012). Emploi de techniques de traitement de signal MIMO pour des applications dédiées réseaux de capteurs sans fil, *Thesis dissertation-UJF-Grenoble I*. <http://tel.archives-ouvertes.fr/tel-00745006>.
- [9] Prayongpun, N. (2009). Modélisation et étude de la capacité du canal pour un système multi-antennes avancé exploitant la diversité de polarisation, *Thesis dissertation-UJF-Grenoble I* <http://tel.archives-ouvertes.fr/tel-00396666/en/>
- [10] Dao, M.T., Nguyen, V.A., Im, Y.T., Park, S.O. & Yoon,G.(2011). 3D Polarized channel modeling and performance comparison of MIMO antenna configurations with different polarizations, *IEEE Transactions on Antennas and Propagation* Vol. 59(No. 7): 2672–2682.
- [11] Soysal, A. and Ulukus, S. (2007). Optimum power Allocation for Single-User MIMO and Multi-User MIMO-MAC with Partial CSI, *IEEE Transactions on Selected Areas in Communications* Vol. 25(No. 7): 1402–1412.
- [12] Serbetli, S. and Yener, A. (2004). Transceiver Optimization for Multiuser MIMO Systems, *IEEE Transactions on Signal Processing* Vol. 52(No. 1): 214–226.
- [13] Bengtsson, M. (2004). From single link MIMO to multi-user MIMO, *Proceedings of IEEE International Conference on Acoustics, Speech, and Signal Processing (ICASSP '04)*, pp. iv-697–iv-700.
- [14] Codreanu, M., Tolli, A., Juntti, M. & Latva-aho, M.(2007). Joint Design of Tx-Rx Beamformers in MIMO Downlink Channel, *IEEE Transactions on Signal Processing* Vol. 55(No. 9): 4639–4655.
- [15] Gomadam, K., Cadambe, V. R., & Jafar, S. A.(2011). A Distributed Numerical Approach to Interference Alignment and Applications to Wireless Interference Networks, *IEEE Transactions on Information Theory* Vol. 57(No. 6): 3309–3322.
- [16] Hassibi, B. and Sharif, M. (2007). Fundamental limits in MIMO broadcast channels, *IEEE Journal on Selected Areas in Communications* Vol. 25(No. 7): 1333–1344.
- [17] Duplity, J., Badic, B. and Balraj, R. (2011). MU-MIMO in 4G systems, *Eurasip Journal on Wireless Communications and Networking* Vol. 2011: 1–12.

- [18] Frank, P., Müller, A. and Speidel, J. (2010). Performance of CSI-based multi-user MIMO for the LTE downlink, *Proceedings of 6th International Wireless Communications and Mobile Computing Conference (IWCMC)*, USA, pp. 1086–1090.
- [19] Frank, P., Müller, A., Droste, H. and Speidel, J. (2010). Cooperative interference-aware joint scheduling for the 3GPP LTE uplink, *Proceedings of IEEE 21st International Symposium on Personal Indoor and Mobile Radio Communications (PIMRC)*, pp. 2216–2221.
- [20] Benjebbour, A., Shirakabe, M., Ohwatari, Y., Hagiwara, J. and Ohya, T. (2008). Evaluation of user throughput for MU-MIMO coordinated wireless networks, *Proceedings of IEEE 19th International Symposium on Personal, Indoor and Mobile Radio Communications (PIMRC)*, pp. 1–5.
- [21] Gesbert, D., Hanly, S., Huang, H., Shamai, S. and Yu, W. (2010). Multi-Cell MIMO Cooperative Networks: A New Look at Interference, *IEEE Journal on Selected Areas in Communications* Vol. 28(No. 9): 1380–1408.
- [22] Spencer, Q. H. and Peel, C. B. and Swindlehurst, A. L. and Haardt, M. (2004). An introduction to the multi-user MIMO downlink, *IEEE Communications Magazine* Vol. 42(No. 10): 60–67.
- [23] Weingarten, H., Steinberg, Y. and Shamai, S. (2006). The Capacity Region of the Gaussian MIMO Broadcast channel, *IEEE Journal on Selected Areas in Communications* Vol. 52(No. 9): 3936–3964.
- [24] Hemrungle, S., Hori, T., Fujimoto, M. and Nishimori, K. (2010). Channel Capacity Characteristics of Multi-User MIMO Systems in Urban Area, *Proceedings of 2010 IEEE Antennas and Propagation Society International Symposium (APSURSI)*, pp. 1–4.
- [25] Tse, D. and Viswanath, P. (2005). Fundamentals of wireless communication, Cambridge University Press, ISBN: 0–521–84527–0.
- [26] Ravindran, N. and Jindal, N. (2007). Limited feedback-based block diagonalization for the MIMO broadcast channel, *IEEE Journal on Selected Areas in Communications* Vol. 26(No.8): 1473–1482.
- [27] Zhang, J. and Andrews, J. G., and Heath, R. W. (2009) . Block Diagonalization in the MIMO Broadcast Channel with Delayed CSIT, *Proceedings of IEEE Global Telecommunications Conference (GLOBECOM)*, Hawaii, pp. 1–6.
- [28] Zhang, R. (2010). Cooperative Multi-Cell Block Diagonalization with Per-Base-Station Power Constraints, *Proceedings of IEEE Wireless Communications and Networking Conference (WCNC)*, pp. 1–6.
- [29] Spencer, Q.H., Swindlehurst, A.L. and Haardt, M. (2004). Zero-forcing methods for downlink spatial multiplexing in multiuser MIMO channels, *IEEE Transactions on Signal Processing* Vol. 52(No.2): 461–471.

- [30] Lee, J. and Jindal, N. (2007). High SNR Analysis for MIMO Broadcast Channels: Dirty Paper Coding versus Linear Precoding, *IEEE Transactions on Information Theory* Vol. 53(No.12): 4787–4792.
- [31] Tarighat, A., Sadek, M. and Sayed, A.H. (2005). A multi user beamforming scheme for downlink MIMO channels based on maximizing signal-to-leakage ratios, *Proceedings of IEEE International Conference on Acoustics, Speech, and Signal Processing (ICASSP)*, Philadelphia, pp. iii/1129–iii/1132.
- [32] Mundarath, J.C. and Kotecha, J.H. (2008). Multi-User Multi-Input Multi-Output (MU-MIMO) Downlink Beamforming Systems with Limited Feedback, *Proceedings of IEEE Global Telecommunications Conference (GLOBECOM)*, pp. 1–6.